

I was walking on the street one day when I came across a craftsman who was making shapes of different animals simply with palm leaves. This experience transported me into an entire different realm of imagination and I wondered "...What if when I found this handmade product and I tried to find out the artisan who created it and to my amazement find the workshop closed down. What could be even worse that I discover that the artist is no more and nobody has ever acquired skills of his traditional art...". It would eventually mean that a certain type of handicraft was lost forever and with this, was lost a significant little part of our culture.



School of Design, Hunan University,
Lushan Road, Yuelu District, Changsha,
Hunan, P.R.China



Azar Publication,
No. 318, 12 Farvardin St. Enghelab Ave.
Tehran, Iran

ISBN 978-600-6862-06-4



9 786006 862064 >

Mohsen Jaafarnia

Toy & Craft

玩具和工艺 Toy



Mohsen Jaafarnia

اسباب بازی و صنایع دستی Craft



اسباب بازی و صنایع دستی

Toy & Craft

玩具和工艺

Mohsen Jaafarnia

محسن جعفرنیا



Tehran, Iran 2015

سرشناسه : جعفرنیا، محسن، ۱۳۵۴ -

عنوان و نام پدیدآور : اسباب‌بازی و صنایع دستی = Toy & Craft / محسن جعفرنیا .

مشخصات نشر : تهران: آذر، ۱۳۹۳.

مشخصات ظاهری : ۱۹۲ ص. : مصور (رنگی).

شابک : 978-600-6862-06-4

وضعیت فهرست نویسی : فیپا

یادداشت : فارسی - چینی - انگلیسی .

موضوع : کاردستی با برگ

موضوع : کاردستی -- راهنمای آموزشی

موضوع : صنایع دستی -- راهنمای آموزشی

رده بندی کنگره : ۱۴۹TT/ج۶الف۵ ۱۳۹۳

رده بندی دیویی : ۷۴۵/۵۸

شماره کتابشناسی ملی : ۳۶۷۸۶۱۷



Title	: Toy & Craft	玩具和工艺	: اسباب بازی و صنایع دستی	نام کتاب
Author	: Mohsen Jaafarnia	Mohsen Jaafarnia	: محسن جعفرنیا	تالیف
Publisher	: Azar	Azar	: آذر	ناشر
Print	: First print 2015	第一次出版 2015	: اول / ۱۳۹۳	نوبت چاپ
Circulation	: e-book	电子书	: e-book	تیراژ
Persian editor	: Sahar Boroomand	Sahar Boroomand	: سحر برومند	ویراستار فارسی
English editor	: Anupa Lahkar	Anupa Lahkar	: آنوپا لاهکار	ویراستار انگلیسی
Chinese editor	: Huang Xing & Ren Jia	黄星& 任佳	: هوانگ شینگ و رن جیا	ویراستار چینی
Chinese translator	: Yinman Guo	郭寅曼	: ایمن گوو	مترجم چینی
Illustration	: Huiwei Huang	黄惠炜	: خوای وی خوانگ	تصویر سازی
Price	: See the next page	参见下一页	: به صفحه بعد مراجعه نماید	بها
ISBN	: 978-600-6862-06-4	978-600-6862-06-4	: 978-600-6862-06-4	شابک

Copyright © Mohsen Jaafarnia, 2015
All rights reserved

دفتر مرکزی انتشارات آذر:
تهران - خیابان انقلاب - ابتدای خیابان ۱۲ فروردین - پلاک ۳۱۸ - انتشارات آذر
تلفن: ۱۵ الی ۶۶۹۶۶۱۱۴ - ۰۲۱

Azar Publication

No: 318, 12 Farvardin St. Enghelab Ave. Tehran , Iran.

Telephone : 0098 21 66966114 - 15

دوست گرامی،

تهیه این نسخه از e-book از طریق جستجوی نام کتاب در اینترنت و یا از طریق سایت دانشکده طراحی، دانشگاه هونان (لینک زیرین) امکان پذیر می باشد و جهت پرداخت بهاء کتاب مبلغی را تا سقف ۱۰۰/۰۰۰ ریال (بسته به میزان درآمد خود) انتخاب نموده و به شماره حساب زیر واریز نمایید.
موسسه خیریه محک ، بانک ملی ، شعبه بندر قشم ، شماره حساب ۰۲۰۵۴۷۶۶۴۰۰۰۶
با تشکر از شما

Dear friend,

You can find a digital copy of this e-book from the web site of School of Design, Hunan University (below link). You can download this book with the price that goes to the noble cause. So, you are requested to pay any amount up to \$ 33 as per your capacity, payment to be done to any charity organizations based in your country (readers in every country must find the exchange rate of dollar then do the payment with their own currency) for example: OLD AGE HOME, HEALTH CARE (CANCER), CHILD LABOUR and so on.

Thank from anticipation

亲爱的朋友，

您可以通过进入湖南大学设计艺术学院的官方网站（链接如下），获取全书的电子版。考虑到这项崇高的事业，您需要支付一定的费用来下载本书。根据您的支付能力，支付金额最多 33 人民币，支付是通过直接捐赠给以下的慈善组织完成的。

谢谢您的期待

壹基金 人民币捐款账户： 开户单位：深圳壹基金公益基金会

银行：招商银行总行营业部 人民币账号：755917671010888 开户行行号：308584001024

Mohsen Jaafarnia

Mohsen Jaafarnia

<http://design.hnu.edu.cn/index.php/faculty-staff/assistant-professor/1516-mohsen>

Contents	内容	Page	فهرست
- Introduction	介绍	1	- مقدمه
- How to use this book	本书使用指南	5	- چگونه از این کتاب استفاده کنیم
- Rose	玫瑰花	7	- گل رز
- Phoenix	凤凰	25	- عنقا
- Peacock	孔雀	54	- طاووس
- Grasshopper	蚱蜢	70	- ملخ
- Dragonfly	蜻蜓	86	- سنجافک
- Bird	鸟	108	- پرندہ
- Frog	青蛙	118	- قورباغہ
- Appendix	附录	148	- ضمیمہ
- References	参考文献	190	- منابع

نویسنده این کتاب محسن جعفرنیا مدرس و پژوهشگر در دانشکده طراحی، دانشگاه هونان، چین می باشد. او بواسطه احترامی که به لائوتسه (فیلسوف چین باستان) قائل است این کتاب را به روح بزرگ او تقدیم می کند.
لائوتسه این مرد بزرگ می گوید:
تنها سه چیز برای تدریس دارم: سادگی، صبر، رحم و شفقت.
این سه، بزرگترین گنجینه های شما خواهند بود.

本书的作者是湖南大学设计艺术学院的助理教授，Mohsen Jaafarnia。他对中国古代哲学家老子有着深厚的敬仰之情。仅以此书献给这位伟大的哲人。

老子曰：“我恒有三宝，一曰慈，二曰俭，三曰不敢为天下先”

The author of this book Mohsen Jaafarnia is an assistant professor of School of Design at Hunan University, China. His deep respect for Lao zi who was a philosopher of ancient China. The author dedicates this book to his great spirit.

Lao zi says:
I have just three things to teach: simplicity, patience, compassion. These three are your greatest treasures.



Acknowledgement

The assistance given by Cai Cao 蔡超, Chen Haoran 陈浩然 , Chen Minghao 陈明昊, Chen Wanrong 陈婉蓉, Chen Xiaoyi 陈晓毅, Cui Ke 崔珂, Ding Qun 丁群, Huang Huiwei 黄惠炜, Li Mingyue 李明月, Li Shuquan 李书全, Li Yujia 李雨佳, Liao Suifang 廖穗方, Luo Ying 罗颖, Wang Wenxu 王文旭, Wu Weicao 吴威操, Yu Yanyong 郁艳勇, Zhang Shuhao 张书浩, Zhong Zhenyu 钟振宇, Zhou Xueqi 周雪琪, Zhou Zhuoman 周卓曼, Zhou Zihan 周姿含, Zhu Feng 朱峰, Lai Jianxun 赖健勋 , Xu Shihui 徐诗卉 and Gao Meng 高梦 during the data collection and documentation are to be acknowledged. The cooperation of Mr. Song Huaxian 宋华先 , handicraft man highly appreciated and acknowledged.

Introduction

I was walking on the street one day when I came across a craftsman who was making shapes of different animals simply with palm leaves. This experience transported me into an entire different realm of imagination and I wondered "... What if when I found this handmade product and I tried to find out the artisan who created it and to my amazement find the workshop closed down. What could be even worse that I discover that the artist is no more and nobody has ever acquired skills of his traditional art...". It would eventually mean that a certain type of handicraft was lost forever and with this, was lost a significant little part of our culture.

Since the craft of each country is associated with vibrant tradition. It is a crucial part of the culture of every country identifying one country with the other.

It is extremely essential for us to revive and sustain these forms of art. The possibilities could lead to an industrialist who converts the technique of production from handmade production (Non-mass production) to mass

介绍

一天，我走在街上，偶遇一位手工艺人，他可以用棕榈叶随意编织出不同的动物。这段经历将我的思绪拉入一个完全不同充满想象的世界，我不禁想到"...假设发现了这个手工艺品后，我想要去找到它的制作者，结果却惊奇地发现生产这些工艺品的作坊已经倒闭了。更糟糕的是，居然没有这样的手工艺人了，再也没有人还掌握着这样一门传统技艺..."若真是这样，这也意味着一门技艺的永远消失，而且随之消亡的，是我们文化中具有重要意义的一小部分。

每个国家的手工艺都与其鲜活的传统紧密相连。它是一个国家独特文化是重要部分。

对我们来说，复兴并维持这些艺术形式至关重要。这种发展潜力则引导实业家转变工业生产的技艺，将

مقدمه

در حال قدم زدن در خیابان بودم، مرد هنرمندی را دیدم که در کنار خیابان مشغول ساختن اسباب بازی های مختلفی با فرم حیوانات از برگ نخل بود. این زمانی بود که در تخیلاتم فرو رفتم و دیدم "...، که اثر هنری دستی را یافتم و دنبال سازنده و کارگاهش گشتم در حالی که در را بسته یافتم و سپس فهمیدم که دیگر آن هنرمند در قید حیات نیست و همچنین هیچ کس کار او را نیاموخته است...". این به این معنی است که ما یک هنر دستی را از دست داده ایم و بالطبع یک بخش از فرهنگمان را.

از آنجایی که صنایع دستی هر کشور با رنگ و بوی سنت آن، بخشی از فرهنگ و هویت آن است، می توانیم برخی از شاخه های صنایع دستی را زنده نگه داریم، مانند زمانی که صنعتگر روش تولید را از تولید دست ساز به تولید انبوه تبدیل می کند (مانند تبدیل روش تولید محصولات سفالی ساخته شده از گل رس که توسط چرخ سفالگری و دست به روش ریخته گری دوغابی تولید می شده است). اما مشکل اینجا است که ما نمی توانیم همه شاخه های صنایع دستی را اینگونه حفظ نماییم.

از آنجایی که تولید این دسته از صنایع دستی، اثرات قابل ملاحظه ای بر مسائل اجتماعی و توسعه اقتصادی دارد، دولت ها همیشه بر اهمیت این موضوع جدی بوده اند. دلایل

production (like pottery using the technique of slip casting) but the quandary of the situation is that, not all hand made products could be reproduced by machine or could be mass produced.

As the production of these types of crafts has a valuable effect on social issues and on the economic development, the following grounds can further elaborate on the value of these crafts:

- Man resorts to certain skills while creating handicrafts owing to the structure of his hands and fingers. The involvement of one's hand and soul of course increases the level of initiative and injects creative traits of the individuals too.
- Ingredients of handicrafts are very simple, available and cheap which is the prominent reason why, they have been able to sustain as independent industry.
- Handicrafts in rural agricultural economy are one of the complementary factors, because it can create ancillary and supplementary income for rural people which can fill the leisure time and of

手工工艺品（非大批量生产）转化成大批量生产（如用注浆成型法来制作陶瓷）。但困难在于，并非所有的手工产品都可以用机器来复制或大批量生产。

生产这类工艺品会对社会问题和经济发展产生重大影响，而以下缘由则可以进一步论证这些工艺品的价值：

- 由于人的手和手指的构造，在制造手工艺品时人需要使用某些技能。这种纳入了手和灵魂的一项工作不仅提高了人的主动性，还为产品注入了个人的创意特质。
- 制作手工艺品所需材料很简单易得且便宜，这也是它们能够长久地保持产业独立的一个突出原因。
- 手工艺行业是农村农业经济中的补足元素之一，因为它能够为农村居民增加收入，填补农闲时间，当然也可以控制农村人口季节性或者永

زیر اهمیت رشد صنایع دستی در جامعه را نشان می دهد:

- صنایع دستی نقش مهمی در تقویت روحیه ابتکار در افراد دارد و امکان بکارگیری ذوق و خلاقیت های فردی را به وجود می آورد، البته نیروی انسانی در این امر جایگاه ویژه ای دارد، چرا که در فرایند تولید این مصنوعات، دست و روح انسان دارای نقشی اساسی می باشد.
- در فعالیت های مربوط به صنایع دستی مواد اولیه مورد استفاده معمولاً از مواد ساده و در دسترس تشکیل می گردد که به آسانی و با بهای نسبتاً ارزان قابل تامین می باشد که این امر خود زمینه ساز ایجاد صنعت مستقل و غیر وابسته می گردد.
- صنایع دستی در مناطق روستایی یکی از عوامل مکمل اقتصاد کشاورزی است. به دلیل دارا بودن پتانسیل ایجاد فرصت های شغلی و کسب درآمد، ایجاد اشتغال جنبی و درآمد مکمل برای روستائیان و خانواده شان در فاصله زمانی بین کاشت و برداشت محصول کرده و ضمن پرکردن اوقات فراغت و بیکاری روستائیان مانع از مهاجرت های گسترده فصلی یا دائمی آنها به عنوان یکی از آسیب های اجتماعی می گردد.
- فعالیت های صنایع دستی به دلیل برخوردار بودن از ویژگی های تکنیکی ساده و بهره گیری از ابزارها و وسایل تکنولوژیکی آسان، به گونه ای می باشد که امکان پرداختن به آنها در جوامع شهری و روستایی وجود دارد.
- صنایع دستی بازتابی از تاریخ و تمدن هر قوم و ملت بوده

course control the seasonal or permanent migration of people to the cities.

- Establishing a workshop of handicraft is quite uncomplicated in every village because it does not need to have high technology and specific tools.

- Handicrafts reflect the history and civilization of every nation, with which people can spread the cultural elements everywhere to preserve the cultural values and customs.

In order to transform this thought process into action we documented the process of making the folk toys in school of design, Hunan University, where Mr. Song Huaxian makes these toys for kids in the street to conserve it forever. This effort also enables us to bring back the now forgotten culture of playing with simplistic toys made by using every day material. It is often believed that these folk toys are patent symbols of the direction we need to take. These toys are a culmination of all the qualities that we do not value today: simplicity, creativity and happiness in the play which is associated with expensive toys.

久性移居城市。

- 在农村建立手工艺作坊并不难，它不需要高科技和指定工具。

- 手工艺品能够反映一个国家的历史和文明，通过手工艺品，人们可以将这些文化元素传递到各个角落，以此来保存文化价值和传承文化习俗。

为了将这种思想过程转化为行动，在湖南大学设计艺术学院，我们将制作民俗玩具的过程都记录下来。宋华先先生在街上为儿童们制作这种玩具，希望将其永久保存下来。这种努力同样帮助我们找回早已被遗忘的一种文化，即与那些用日常材料制作的简单玩具玩耍的文化。人们通常相信这些民俗玩具就是我们努力方向的重要象征。与昂贵的玩具相比，这些玩具将所有现在没有重视的品质都做到了极致：简单、创新、快乐。

و به دلیل بر خورداری از بار فرهنگی و دارا بودن جنبه های هنری می تواند عامل ترویج عناصر فرهنگی در نقاط مختلف کشور و حتی فراسوی مرزها باشد که باعث حفظ ارزش های فرهنگی، آداب و رسوم دیرینه و اصالت های موجود در جامعه می گردد.

بنابراین ما روند ساخت اسباب بازی های محلی را که آقای سونگ هوگزیان آنها را برای بچه ها در کنار خیابان می ساخت را در مدرسه طراحی دانشگاه هونان مستند سازی نمودیم تا برای همیشه این هنر دستی را زنده نگاه داریم و این نیز تلاشی است برای بازگرداندن کیفیت بازی های فراموش شده که از ساخت با مواد در دسترس و بازی با اسباب بازی های محلی بوجود می آیند. همانطور که ما معتقدیم که این اسباب بازی های محلی، یک ثبت نماد برای هدف ما که زنده نگاه داشتن فرهنگ است به حساب می آیند. آنها بسیاری از ویژگی های ارزشمند را زنده نگاه می دارند، ویژگی هایی که امروز ما کمتر به آنها توجه می نماییم. مانند: سادگی، خلاقیت و شادی در بازی که معمولا در بیشتر مواقع به اسباب بازی های گران ارتباط نمی یابد.

در آغاز ما مصاحبه ای را با آقای سونگ هوگزیان داشته ایم. او جوان ۲۸ ساله و اهل شهرستان آنکانگ، استان شآنشی می باشد، که در روستای لان گائو رشد یافته است و بعد از دست دادن پدرش در سن ۱۲ سالگی آنجا را ترک می نماید. او می گوید که این هنر را به عنوان یک کار از کودکی آغاز کرده است، و سبک کارش مختص به خود او

Right at the beginning we have had an interview with Mr. Song Huaxian. Mr Huaxian a 28 year old man from Shaanxi province, AnKang city, who grew up in a village of Lan Gao which he had left after his father's demise at the age of 12.

He narrates how he took up the task of toy making since his childhood. When asked what his job is, his reply was that this is his job only which he makes toys (animal feature) just for 5 ¥.

一开始，我们采访了宋华先先生，初步了解了他的个人情况：宋华先，28岁，来自陕西安康，在岚皋县长大，12岁父亲离世后离开故乡。整个过程中，他讲述了从童年时期起，如何开始从事玩具制作这项工作。问及他的工作时，他的回答是这样的，他只是想以五元的价格出售他制作的（动物形态）玩具。

می باشد. از او پرسیدم که کار اصلیت چیست؟ او پاسخ داد، این کار اصلیش می باشد که در ازای هر یک اسباب بازی (فرم های حیوانی) که برای کودکان می سازد، فقط ۵ ¥ دریافت می کند.

How to use this book

The toys demonstrated in this book are made by Mr. Song Huaxian simply out of palm leaf. They are not the regular toys that people can buy easily in shops (especially since most toys are expensive today). Therefore anyone who can access these leaves can make these types of toys. A similar leaf can be used or even colored ribbons could replace the palm leaf. One just has to make sure it has similar properties, like the thickness or the way it bends.

Therefore when we make a folk toy, the target is different age groups. The kids could be happy simply by playing with toys, but adults develop interest in making these toys from simple products. This could probably lead some adult to make these toys for their children.

So we designed this book so that the benefits of this book could be availed by different age groups. Of course this does not necessarily mean that toy makers must follow our methods strictly. As a necessary tool using a pair of scissors would be enough.

如何使用本书

本书展示的玩具都是由宋华先用棕榈叶制作而成，它们与平常能在商店里购买到的日常玩具有所区别（特别是现在大多数玩具都非常昂贵）。任何人只要能拿到这种树叶就能制作这种玩具。类似的树叶也可以用，甚至彩色绸带都可用来替代棕榈叶。选择材料的时候，只需确保它们具有相似的属性，譬如相同的厚度或者弯曲时的状态。在我们制作民俗玩具时，主要对象是不同年龄的群体。小孩子能够单纯地从玩玩具中获得快乐，而成年人也会在制作这些简单产品的培养兴趣。这也许能够引导大人们为他们的孩子亲手制作玩具。

因此我们创作这本书的目的，在于能够使各个年龄群体的人都能受益。当然，制作玩具的人并不需要严格遵守我们的制作方法和流程，

نحوه استفاده از این کتاب

اسباب بازی های این کتاب را آقای سونگ هوگزیان فقط از برگ نخل ساخته است. آنها مانند اسباب بازی هایی که هر کس می تواند در مغازه ها بیابد نیستند (به خصوص که امروزه بیشتر اسباب بازیها گران قیمت می باشند). بنابراین هر کسی که به این نوع برگ دسترسی داشته باشد می تواند این نوع از اسباب بازی ها را بسازد، حتی اگر شما به برگ نخل که او استفاده کرده است دسترسی ندارید، می توانید ماده ای مشابه را جایگزین کنید. برای مثال اگر شما برگ نخل ندارید، می توانید از نوارهای ربان رنگی استفاده نمایید. فقط مطمئن شوید که ربانها از ویژگی های مشابهی مانند ضخامت و یا حالت خم شدن برخوردار می باشند. بنابراین زمانی که ما اسباب بازی های محلی را می سازیم، به روش مختلف گروه های سنی متفاوت را مورد پوشش و هدف قرار می دهیم. بچه ها با فقط بازی با اسباب بازی خوشحال می شوند، اما بزرگسالان بیشتر کنجکاواند بدانند که، چگونه می توانند با این نوع از اسباب بازی برای خود یک شغل ایجاد نمایند و قطعا برخی از بزرگسالان می خواهند طرز ساخت این اسباب بازی ها را یاد بگیرند تا برای کودکان خود بسازند. بنابراین ما این کتاب را برای پوشش گروه های سنی مختلف طراحی نموده ایم. البته این بدان معنا نیست که سازنده اسباب بازی باید روش ما را دنبال نماید. به عنوان ابزار لازم فقط شما نیاز به قیچی دارید نه بیشتر. در اینجا، ما گام به گام توضیح می دهیم که چگونه این اسباب بازی ها

Here, we explain in details how to make these toys, step by step. Each step is illustrated. But sometimes a toy does not look how it is supposed to. Maybe there is nothing wrong with the way it is made, one may just require some practice to acquire the skill and pay specific attention to an each step while making it. So go ahead and follow these instructions carefully.

但是一把剪刀必不可少。
在本书中，我们分步骤详细地解释如何制作这些玩具，每个步骤都配有图片。但有时一个玩具制作出来会与预想的模样有所差距。可能这同制作方法本身并没有关系，需要的只是更多的练习来掌握这门技艺，以及在制作过程中对每个步骤多加关注。那么，让我们跟随这些指导开始动手制作吧。

را بسازید. تصاویر هر مرحله روش ساخت را نشان می دهد. اما گاهی اوقات شما یک اسباب بازی را نمی توانید آنچنان که باید باشد بسازید. شاید هیچ مشکلی در روش ساخت شما وجود نداشته باشد و ممکن است فقط نیاز به کمی تمرین برای به دست آوردن مهارت و یا نیاز به توجه بیشتر به یک یک مراحل ساخت داشته باشید. پس با دقت کردن در دستورالعمل ها بیایید شروع کنیم .

Let's start by Rose

Skill of gift wrapping adds much value to any occasion while presenting a gift to the gift receivers and it makes cute gifts on Mother's Day, Birthday and so on.

This is a step by step guide on making a rose with palm leaf.

1- Cut the leaf of palm similar to the picture to make a stem for the rose and two strips for the petals.

2- Start with the middle of the leaf. Cut and keep half of the strips, put them on either sides and fold the stem on strips like picture.

3- Fold them one by one to make the shape of a triangle. The fold must be made downwards.

4-Start wrapping the leaf strips inwards each time by folding, this will be your rose center roll.

5- Start by taking the long end, and fold them backwards, and wrap it around the center. While one hand on the wrap, make sure the other hand is holding the bottom stem part. Never let the stem go, or it will become loose.

6- Shape it into a rose as you go. Keep the top

如何织出玫瑰

不论在任何场合，将礼物呈现给收礼物的人时，礼品包装的技能都能为礼品增值不少。比如在母亲节，生日等时候制作可爱的礼物。

以下是用棕榈叶制作玫瑰的步骤。

1-将棕榈叶剪成如图所示的形状，用来制作玫瑰的茎，两片叶子用来制作花瓣。2-从叶子的中部开始，剪开并保留叶子的一半，如图将它们放到两边，并将茎向两片叶子方向折叠。3-依次折叠左右两片叶子，折成三角形。须注意，必须向下折叠。4-向内折叠两片叶子，这是玫瑰的中心辊。5-从长的一端开始，反方向折叠，围绕中心来包裹。一只手在包裹时，注意确保另一只手是握紧底部的茎的，不要让它松动。6-接着将它做成一朵玫瑰的形状。保持顶部是合拢的状态，用缠绕的树叶包裹在其周围。一定

بیا با گل رز شروع کنیم

مهارت کادو کردن، در هر موقعیتی ارزش بالایی هنگام دادن هدیه به گیرنده آن اضافه می کند و باعث بوجود آمدن هدایای زیبایی در روز مادر- روز تولد و دیگر مراسم می گردد.

توضیحات زیر یک راهنمای گام به گام برای ساختن یک رز از برگ پالم می باشد.

۱- مطابق تصویر برگ نخل را برای ساخت ساقه گل رز و دو زیانه برای گلبرگ ها برش بزنید.

۲- از وسط برگ شروع کنید. برش مورد نظر را داده و نیمی از نوار برش خورده را نگاه دارید. آنها را روی یکدیگر قرار داده و تا کنید سپس مطابق تصویر ساقه را روی نوارها تا کنید.

۳- آنها را یکی یکی تا کرده تا شکل یک مثلث ساخته شود. تا باید به سمت پایین باشد.

۴- همزمان با تا کردن نوارها، آنها را به دور ساقه که همان مرکز رز می باشد ببچانید.

۵- انتهای نوار را به سمت عقب تا کرده و آن را به دور ساقه ببچانید. هنگامیکه با یک دست خود مشغول ببچیدن هستید، با دست دیگر خود قسمت پایین ساقه را نگه داشته و به هیچ عنوان آن را رها نکنید.

۶- تایی بالا را نگه داشته و برگ را به دور ساقه ببچانید. از قرارگیری تاها که همان گلبرگهای رز می باشند در نقطه بالایی ساقه و در یک ارتفاع مشخص اطمینان حاصل کنید.

fold, wrap the leaf strip around. Be sure to keep the top of the ribbons at the same height.

7-Repeat until you have about 20 centimeter of tapes left (which is the end of palm leaf and more narrow).

8- Wrap the narrow part of tape around the stem till the end of the strip. Tie it so that it will not loosen. Take another palm leaf to cut rose leaves and put them in the stem part.

要保持所有带子的顶部在同一高度。7-重复这个过程，直到树叶还剩下 20 厘米（这是树叶的最末端，叶子更窄）。8-围绕茎部缠绕树叶余下的狭窄部分，直到最末端。系紧，使它不会松动。再拿另外一片棕榈叶，剪成玫瑰叶子，并把它们固定在茎部。

۷- این کار را تکرار کرده تا جایی که فقط ۲۰ سانتیمتر از نوارتان باقی ماند (پایان برگ نخلتان می باشد و باریکتر است).

۸- قسمت باریک نوار را به دور ساقه تا پایان نوار پیچانده و سپس آن را گره بزنید تا شل و یا باز نشود. برای درست کردن برگهای رز برگ دیگری را انتخاب کرده و آنها را برش زده و به ساقه متصل نمایید.









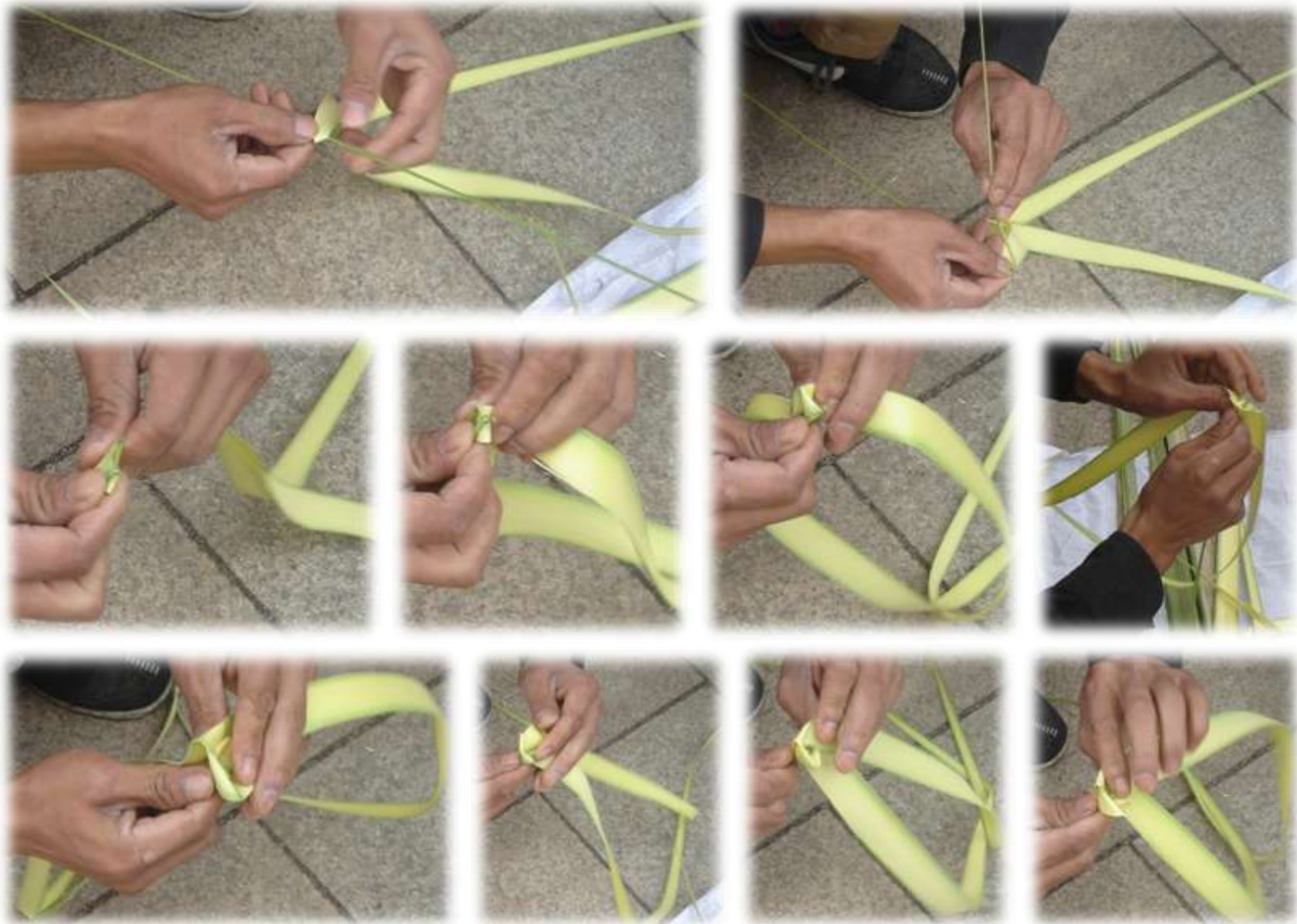













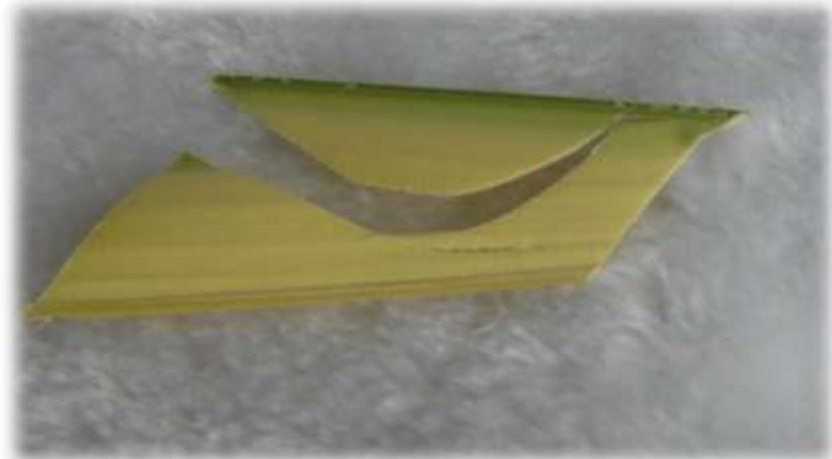
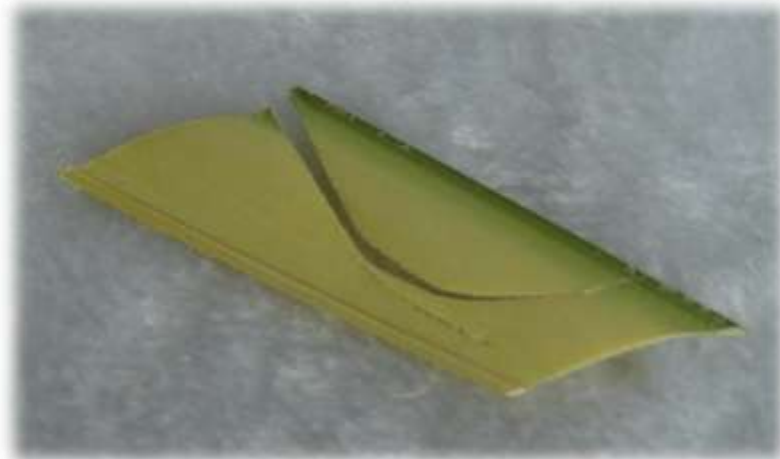









1

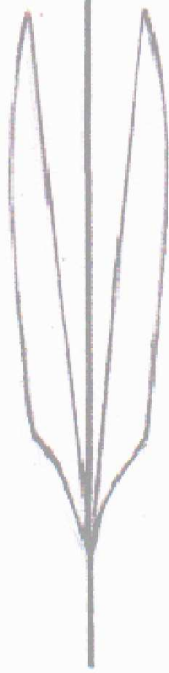

2

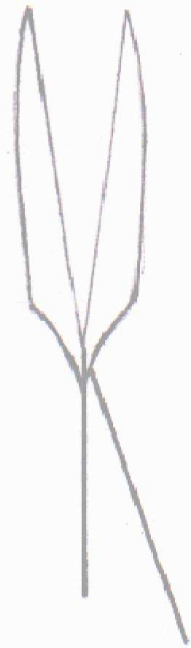

3

Fold down the leaf stalk



4

Make the leaves gather on the left

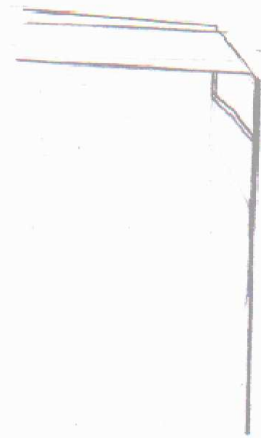

5

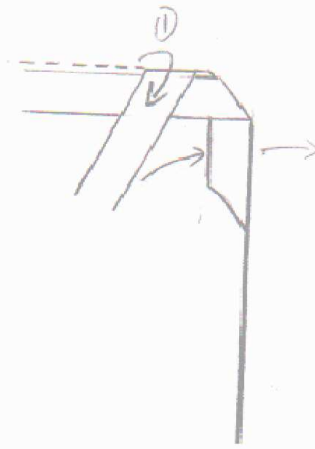

6

After folding the leaf, pull it along the direction of arrow

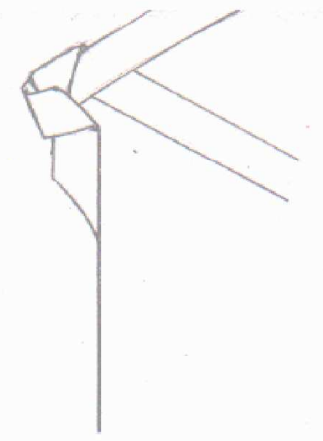

7

After the previous step can get this shape

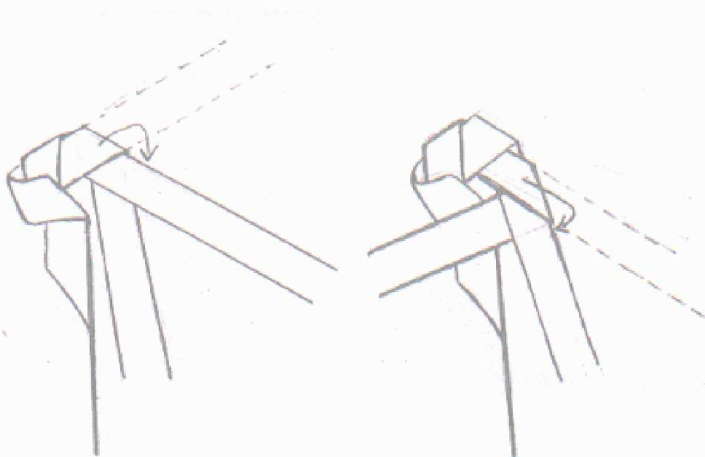

8

9

Do the same with the step 8, and make it around the center while repeating this step

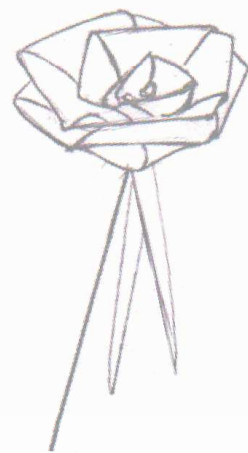

10

The more times you repeat, the bigger rose you will get



11

After compiling the petals, make the rest of the leaf wrapped in leaf stalks as the picture shown



12

Cut out the shape as the picture shown

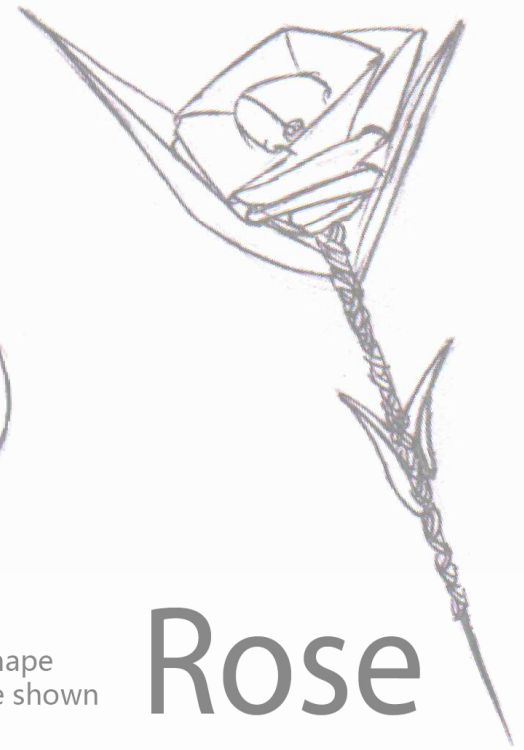

Rose

Let's make the Phoenix

One thing to always remember that, nothing can be enjoyable for kids other than spending time for them. Therefore when you spend time with them to make a toy, it makes them happier than playing with expensive toys.

Here step by step instructions are made to make a Phoenix with a palm leaf.

1- Cut the leaf of palm similar to the picture to make the Phoenix and separate half of the midrib of the leaf.

2- Start with the middle of the leaf strips.

3- Take the midrib of the leaf to roll it into a circle and tie the two strips of leaf on rolled midrib one by one to develop the shape of a Phoenix body.

4- After a couple of 6 ties, prepare 6 strips and fold them from the midside and put them on the body of the Phoenix (for purpose of wings) and then tie the main two strips. Again two ties, prepare a strip and fold them from the middle side then put it on the body of Phoenix (for purpose of legs) and tie the main two strips to finish the form of Phoenix body.

如何织出凤凰

有一件事情我们要永远记住，那就是没有什么比花时间陪伴孩子能使他们更愉快开心。因此，当你花时间和他们一起制作玩具的时候，他们比玩昂贵玩具时更开心。

以下是利用棕榈叶制作凤凰的步骤。

1-将棕榈叶剪成如图所示的形状，将叶子的中脉分开一半。2-从树叶的中部开始。3-将叶的中脉卷成一个圈，然后将两片树叶分别依次与卷好的中脉打结系在一起，固定出凤凰的身体形状。4-在完成了 6 组打结后（左右两片树叶各打一个结算一组），再重新准备 6 条树叶，从中间折叠它们，把它们放在凤凰的身体上（作为凤凰的两翼），并系紧主体的两片树叶。再打两个结，准备一片树叶，从中间折叠它们，然后把它放在凤凰的身体上

روش ساخت عنقا

هیچ زمان این نکته را فراموش نکنید که برای کودکان، هیچ چیزی به اندازه وقت صرف کردن برای آنها لذت بخش نمی باشد. بنابراین هنگامیکه برای ساختن یک اسباب بازی زمان خود را با کودکان می گذرانید، در حقیقت اسباب بازی با ارزشی را می سازید که آنها را حتی از بازی با یک اسباب بازی گران قیمت بیشتر خوشحال می کند.

توضیحات زیر یک راهنمای گام به گام برای ساختن یک عنقا از برگ نخل می باشد.

۱- مطابق تصویر برگ نخل را برای ساخت عنقا برش زده و نیمی از رگ میانی برگ را جدا کنید.

۲- کار خود را از وسط نوار برگ برش خورده شروع کنید. ۳- رگ میانی برگ را شبیه دایره پیچانده و برای فرم دادن بدن عنقا، دو نوار برش زده را یکی یکی به دور رگ میانی پیچانده شده گره بزنید.

۴- پس از ایجاد کردن شش جفت گره، شش عدد نوار را آماده کرده و از قسمت وسط تا کنید. سپس روی بدن عنقا قرار دهید (به عنوان بالهای آن) و دو نوار اصلی را گره بزنید. دوباره پس از زدن یک جفت گره، یک نوار را آماده کرده و آن را از قسمت وسط تا کرده و سپس روی بدن عنقا قرار دهید (به عنوان پاهای آن) و دو نوار اصلی را گره زده تا مرحله شکل گیری بدن عنقا پایان یابد.

۵- هنگامیکه با یک دست خود مشغول کار هستید، با دست دیگر خود قسمت بدن را نگه داشته و به هیچ عنوان آن را

5- While one hand is working, make sure the other hand is holding the body part. Never let it go, or it will become loose.

6- Shape the next strip by scissors to form the legs.

7- Make hole on wings by sharpness of scissors to put a stick, in this time Shape the wings by hand.

8- Cut a head out of palm leaf and put it inside the rolled midrib and tighten it.

9 -For the last step Cut the tail of Phoenix.

(作为腿)，并再系紧主体的两片树叶，完成凤凰身体的形态。5-当一只手在制作时，保证另一只手是握紧身体部分的。不要让它滑动或松动。6-用剪刀将腿的形态修剪出来。7-用剪刀尖端在翅膀上戳孔，插入棍子，同时用手塑形翅膀。8-在另外的棕榈叶上剪出凤凰的头，并把它放入卷成圈的中脉中并固定紧。9-最后一步，修剪出凤凰的尾巴。

رها نکنید.

۶- برای فرم دادن پاها بوسیله قیچی نوار بعدی را برش بزنید.

۷- بوسیله نوک تیز قیچی روی بالها سوراخ ایجاد کرده تا بتوانید از طریق این سوراخها، باریکه ای برش زده از قسمت رگ میانی برگ را عبور دهید. در این مرحله، بالها را با دست خود فرم دهید.

۸- قسمتی از برگ را برای درست کردن سر برش داده و در قسمت رگ میانه پیچانده شده قرار دهید و سپس آن را گره بزنید.

۹- در آخر، قسمت دم عنقا را با قیچی برش بزنید.





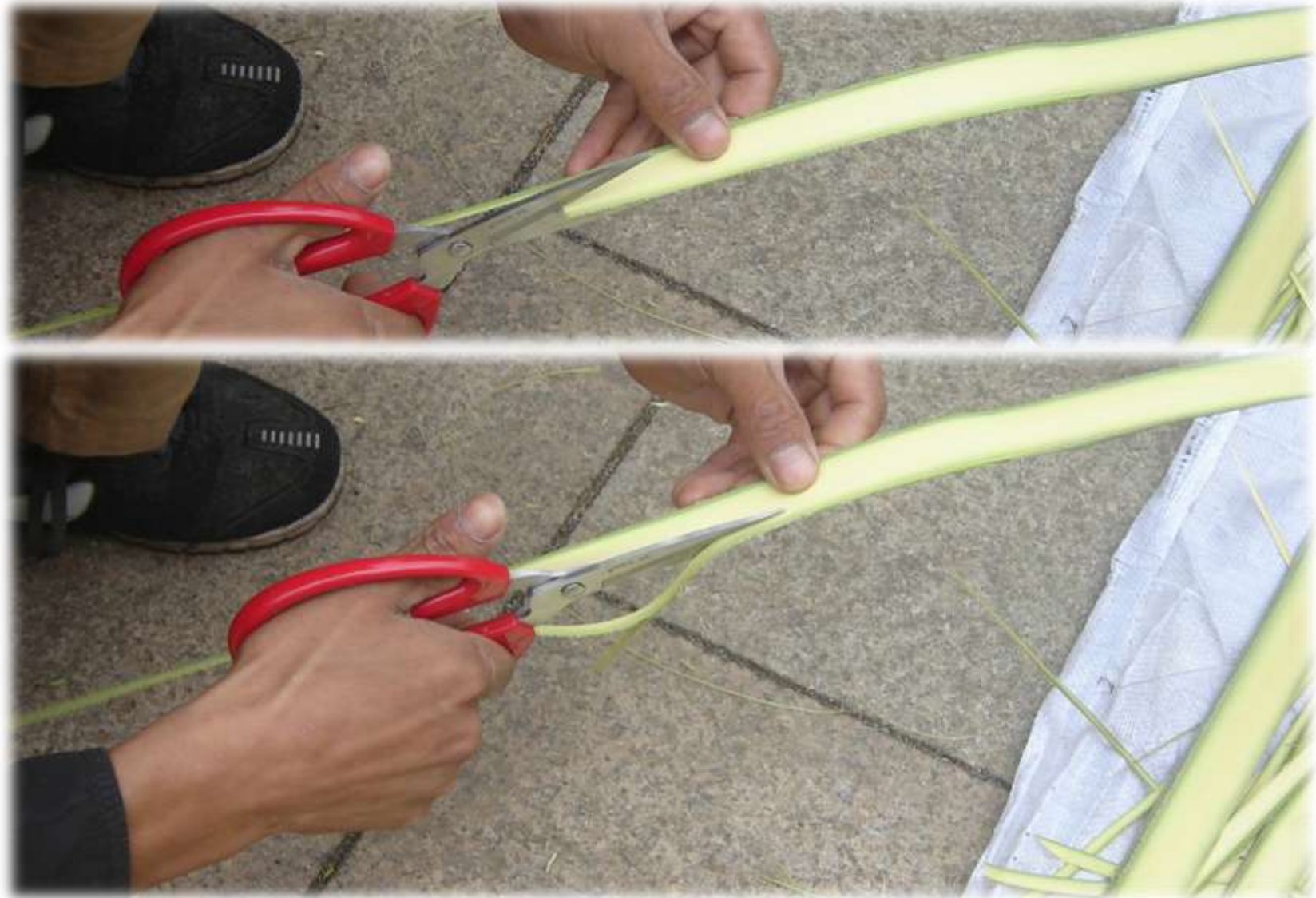





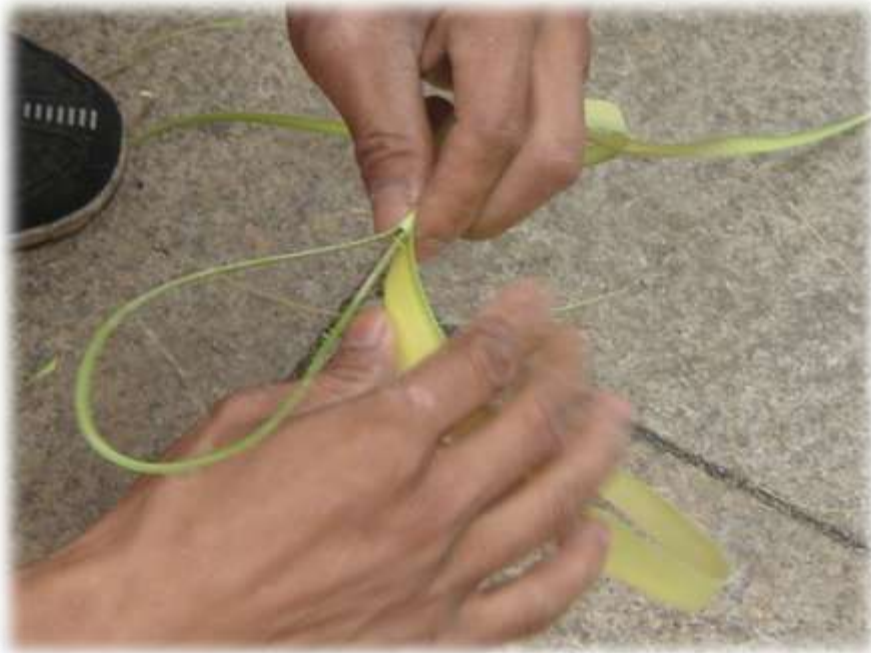



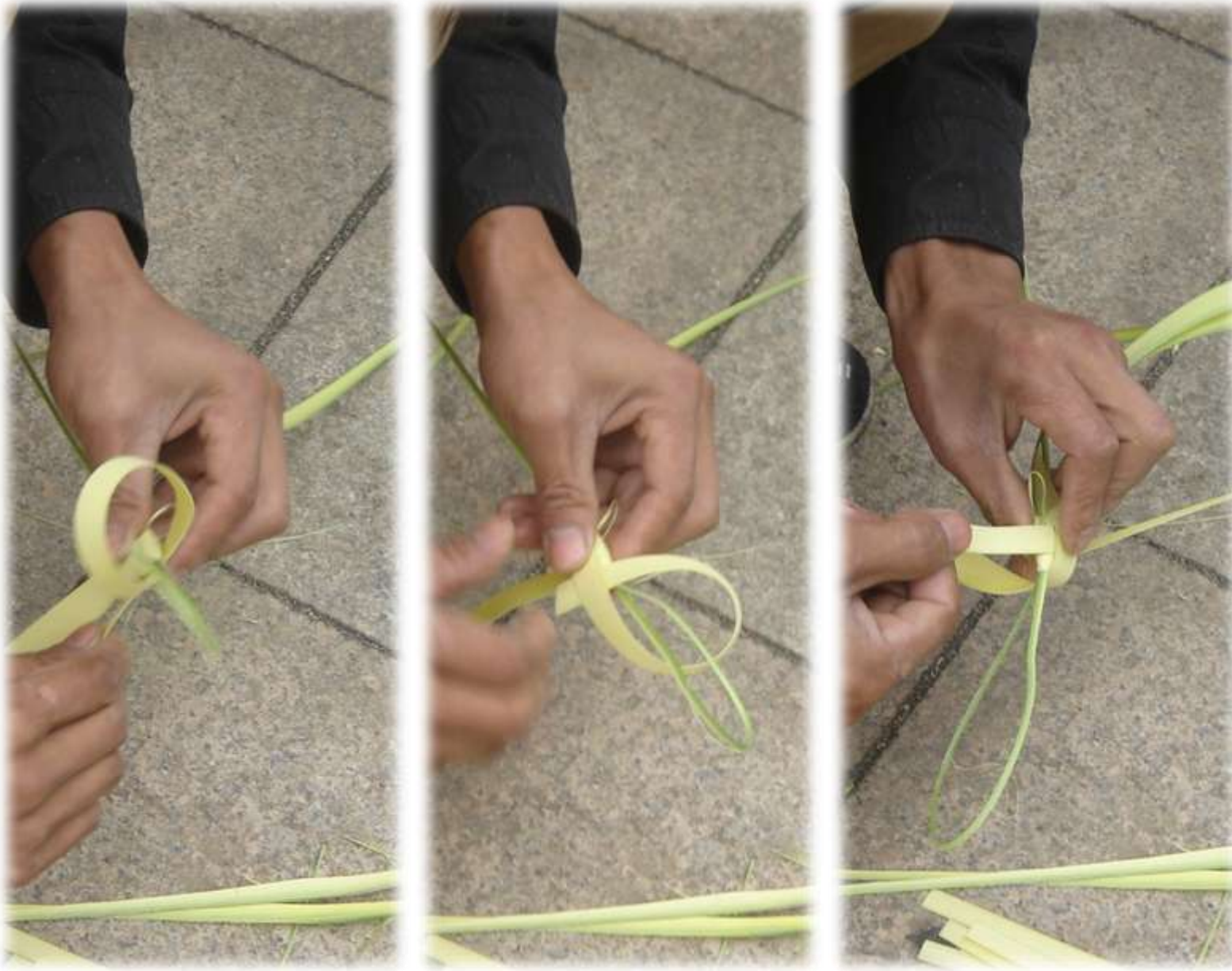







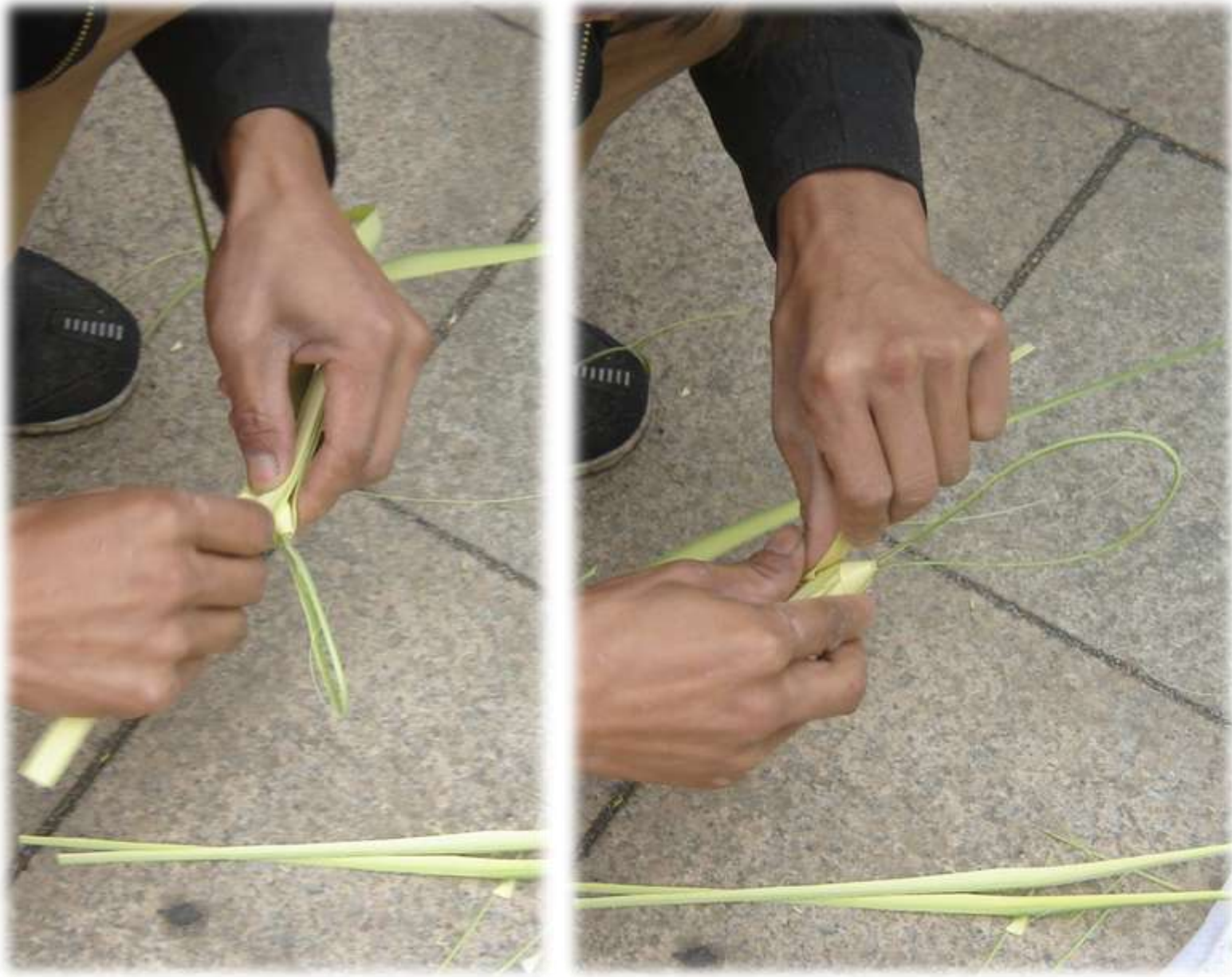

















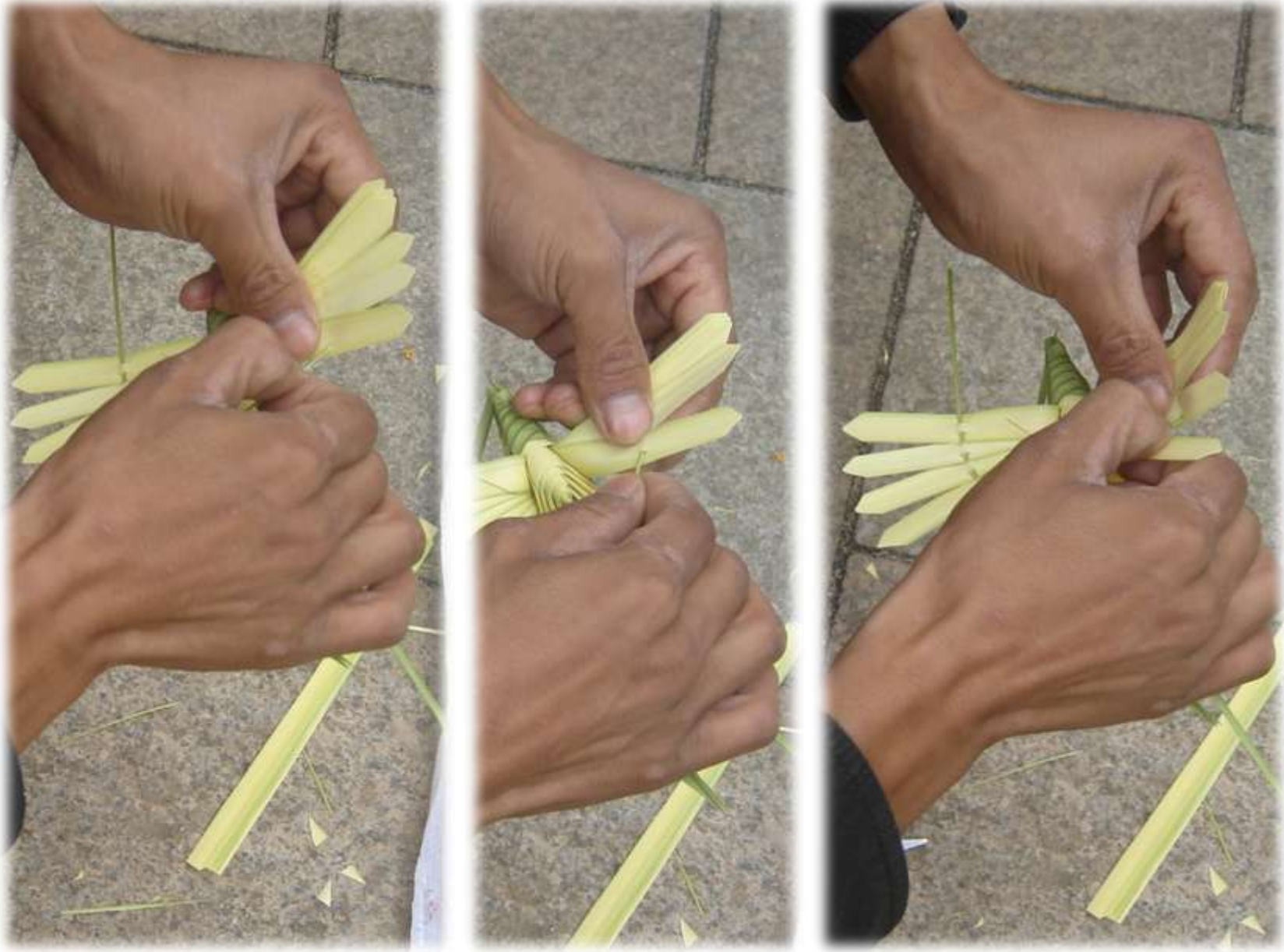













1

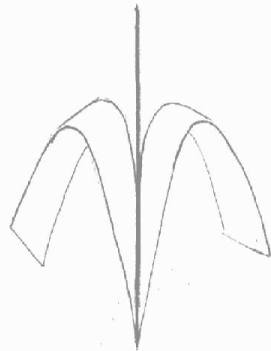

2



3

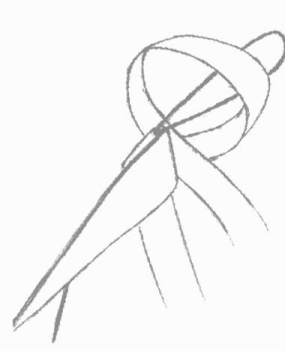

4

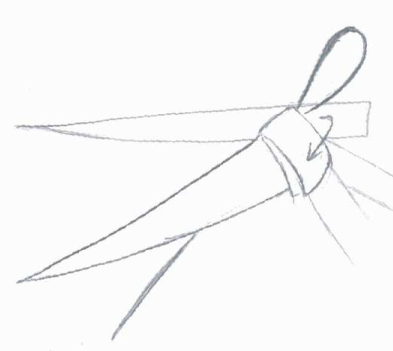

5

Insert two pieces of leaves to make it appear like tails

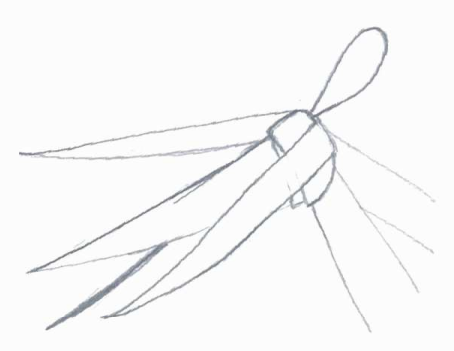

6

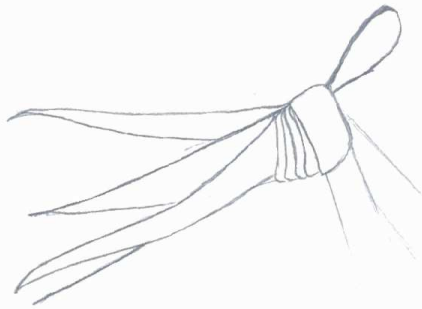

7

Repeat step 3-4 for 2 times

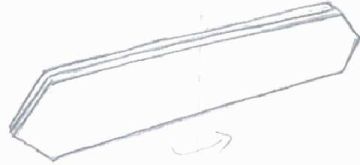

8

Shape out five pieces of leaves as shown above and fold them into half

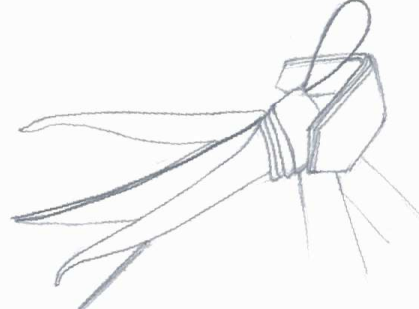

9

Add the wings

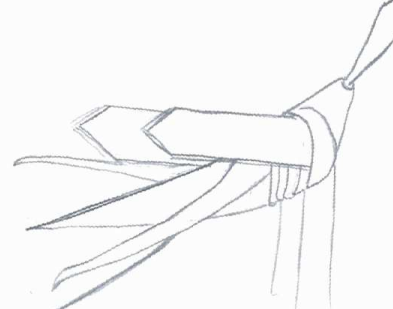

10

Repeat step 3-4 for 2 times

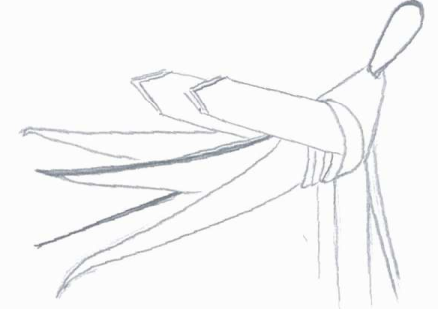

11

split small parts of the leaves edge



12

Repeat step 3-4 until it is beautiful enough



13

Use scissor to cut out the shape of head



14

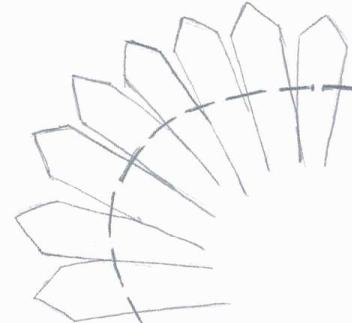

15

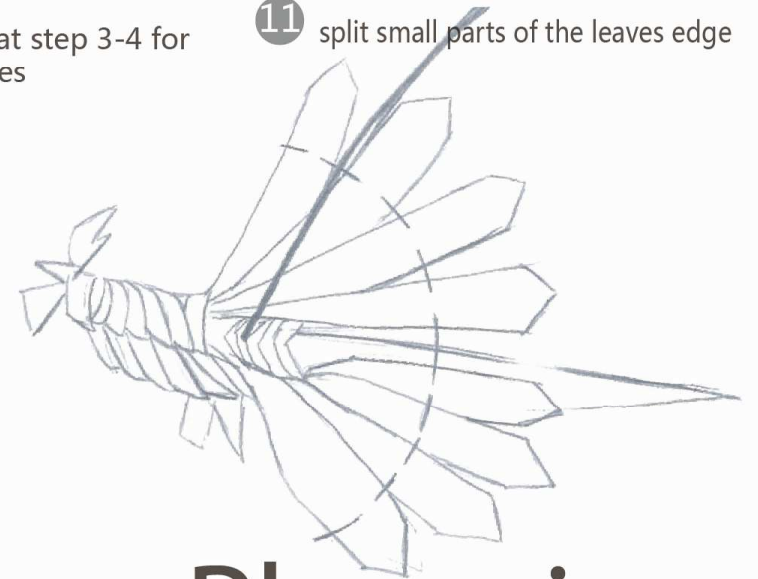

Phoenix

Let's make the Peacock

Do not forget, kids want to understand that how the toy has been made therefore this is the best time for you to make the toy in front of kids making them imitate you.

This is a step by step guide on making a Peacock with palm leaf.

1- Take 2 strips of palm leaf to shape out the tail of the Peacock.

2- Cut the palm leaf similar to the picture, to make the body of Peacock then split half of the midrib of leaf.

3- Start with the middle of the leaf strips.

4- Take the midrib of leaf to roll it into a circle and tie the two strips of leaf rolled midrib one by one to make the shape of a Peacock body.

5- After a couple of 3ties, fold a strip from the middle then put them on the body of the Peacock (for the purpose of the tail) and tie the main two strips. After a couple of 3ties, prepare 5 strips and fold them from the middle, then put them on the body of the Peacock (for the purpose of the wings). After two ties, prepare one strip and fold them from the middle then

如何织出孔雀

别忘了，孩子们想要知道如何制作这些玩具，在小孩子面前制作玩具是让他们模仿你的最好时机。

以下是利用棕榈叶制作孔雀的步骤。

1-取 2 片棕榈叶做出孔雀的尾巴。

2-如图裁剪棕榈叶，用来制作孔雀的身体，将叶中脉劈开一半。3-从树叶的中部开始。4-将叶的中脉卷成一个圈，将两片树叶分别依次与卷好的中脉打结系在一起，做出孔雀身体的形状。5-在完成了 3 组打结后（左右两片树叶各打一个结算一组），将另一片树叶从中间折叠一下，然后放在孔雀的身体上（作为尾巴），并用主体的两片树叶打结系紧。在打了 3 组结后，再准备 5 片树叶，并从中间折叠它们，把它们放在孔雀身体上（作为两翼）。再打两个结后，准备 1 片树

روش ساخت طاووس

فراموش نکنید که بچه ها می خواهند از روش ساخت اسباب بازی هایشان مطلع شوند، بنابراین این بهترین زمان برای شما می باشد که در مقابل چشم هایشان اسباب بازی بسازید، بعد از آن آنها شروع به تقلید کردن از شما در ساخت یک اسباب بازی نموده که البته اولین قدم خلاقیت، تقلید کردن می باشد.

توضیحات زیر یک راهنمای گام به گام برای ساختن یک طاووس از برگ نخل می باشد.

۱- دو عدد برگ نخل را برداشته و از درون آنها دم طاووس را برش بزنید.

۲- مطابق تصویر برای ساخت بدن طاووس برگ نخل را برش زده و سپس نیمی از رگ میانی برگ را جدا کنید.

۳- از وسط برگ شروع نمایید.

۴- رگ میانی برگ را شبیه دایره پیچانده و برای فرم دادن بدن طاووس دو نوار برش زده را یکی یکی به دور رگ میانی انحنای داده شده گره بزنید.

۵- پس از ایجاد کردن سه جفت گره، یک عدد نوار را از قسمت وسط تا کنید و سپس روی بدن طاووس قرار دهید (به عنوان دم آن) و دو نوار اصلی را گره بزنید. دوباره پس از زدن سه جفت گره، پنج عدد نوار را آماده کرده و آنها را از قسمت وسط تا نموده و سپس روی بدن طاووس قرار دهید (به عنوان بالهای آن). دوباره پس از زدن یک جفت گره، یک عدد نوار را آماده کرده و آن را از قسمت وسط تا

put it on the body of Peacock (for purpose of legs) and tie the main two strips to finish the form of the Peacock body.

6- While one hand is working, make sure the other hand is holding the body part. Never let it go, or it will become loose.

7- Shape the next strip by scissors to form the legs

8- Cut the back tail then make hole on the wings with the edge of the scissors to insert a stick ,this time Shape the wings by hand.

9- Cut a head out of palm leaf and put it inside the rolled midrib and tighten it.

叶，并从中间折叠它，然后放在孔雀的身体上（作为腿），并用主体的两片树叶打结系紧，完成孔雀身体的形态。6 -当一只手在制作时，保证另一只手是握紧身体部分的。不要让它滑动或松动。7 -用剪刀来修剪树叶形成腿的形状。8 -剪掉最后的尾部，再用剪刀锋利的边缘在翅膀上戳孔，插入棍子，同时用手塑形翅膀。9 -在另外的棕榈叶上剪出头部，并把它放入卷成圈的中脉中并固定紧。

نموده و سپس روی بدن طاووس قرار دهید (به عنوان پاهای آن) و دو نوار اصلی را گره زده تا مرحله شکل گیری بدن طاووس پایان یابد.

۶- هنگامیکه با یک دست خود مشغول کار هستید، با دست دیگر خود قسمت بدن را نگه داشته و به هیچ عنوان آن را رها نکنید.

۷- برای فرم دادن پاها بوسیله قیچی نوار بعدی را برش بزنید.

۸- قسمت دم طاووس را برش زده و بوسیله نوک تیز قیچی روی بالها سوراخ ایجاد کرده تا بتوانید از طریق این سوراخها، باریکه ای برش زده از قسمت رگ میانی برگ را عبور دهید. در این مرحله، بالها را با دست خود فرم دهید.

۹- قسمتی از برگ را برای درست کردن سر برش داده و در قسمت پیچانده شده قرار دهید و سپس آن را گره بزنید.













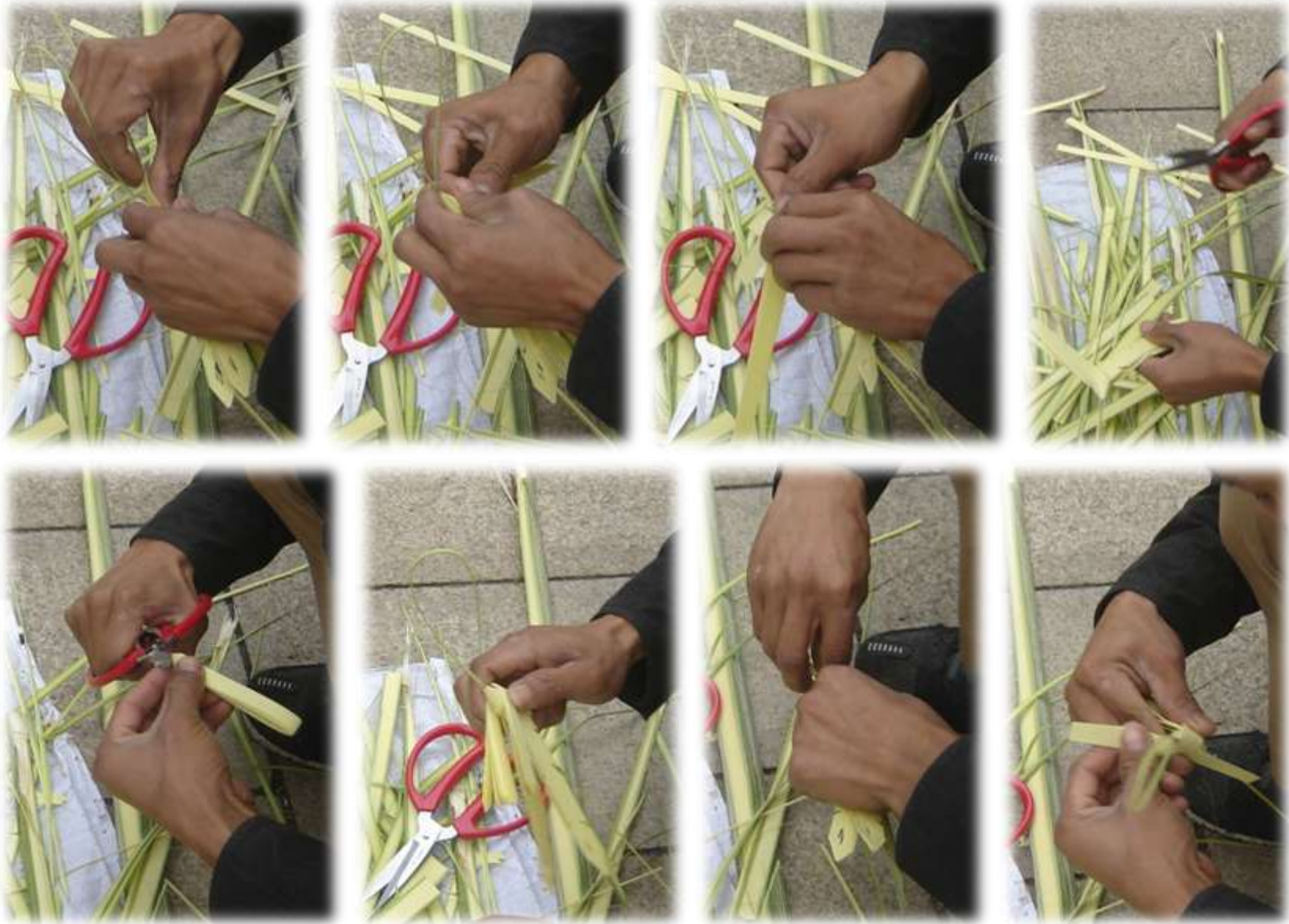

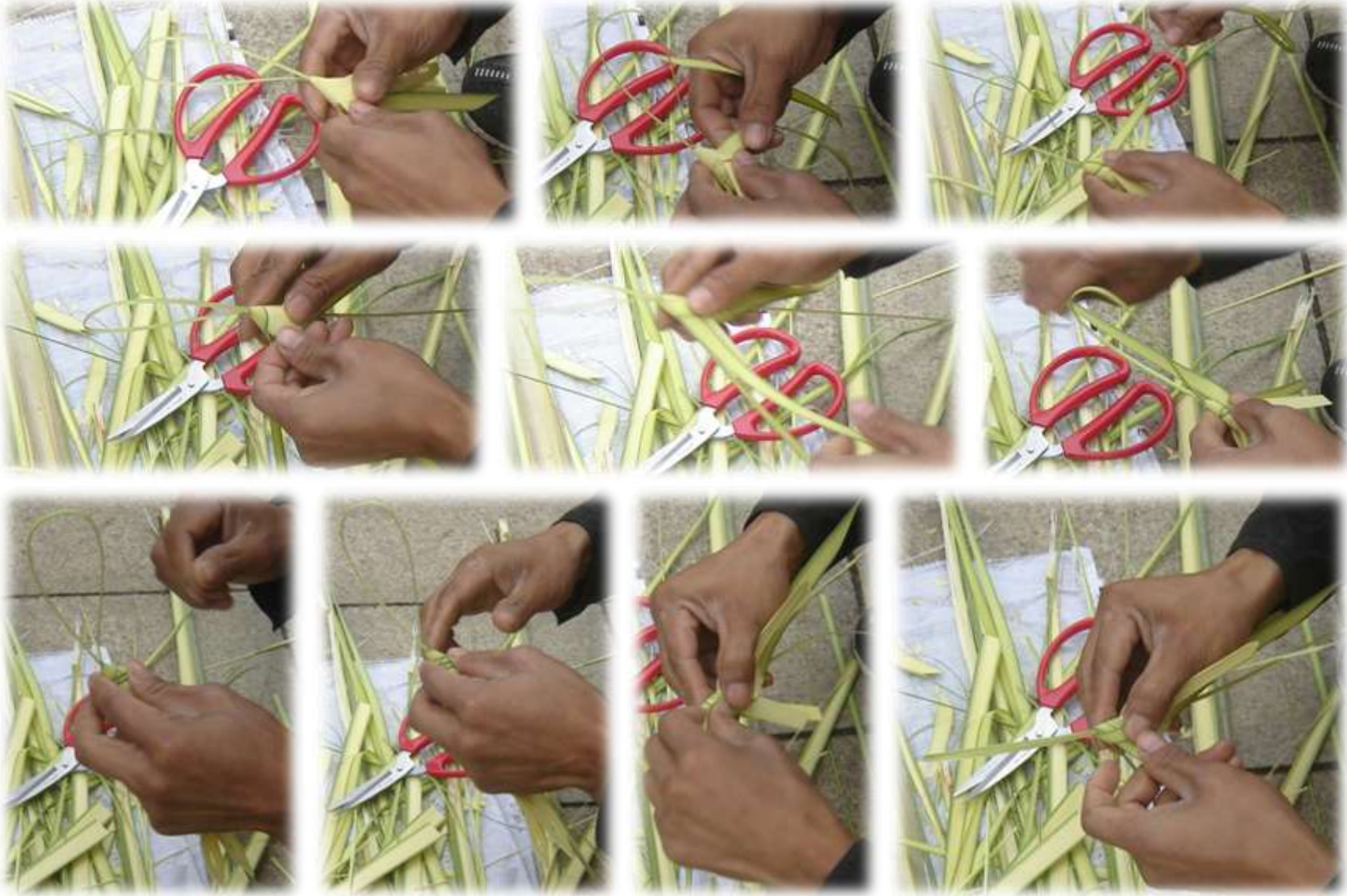



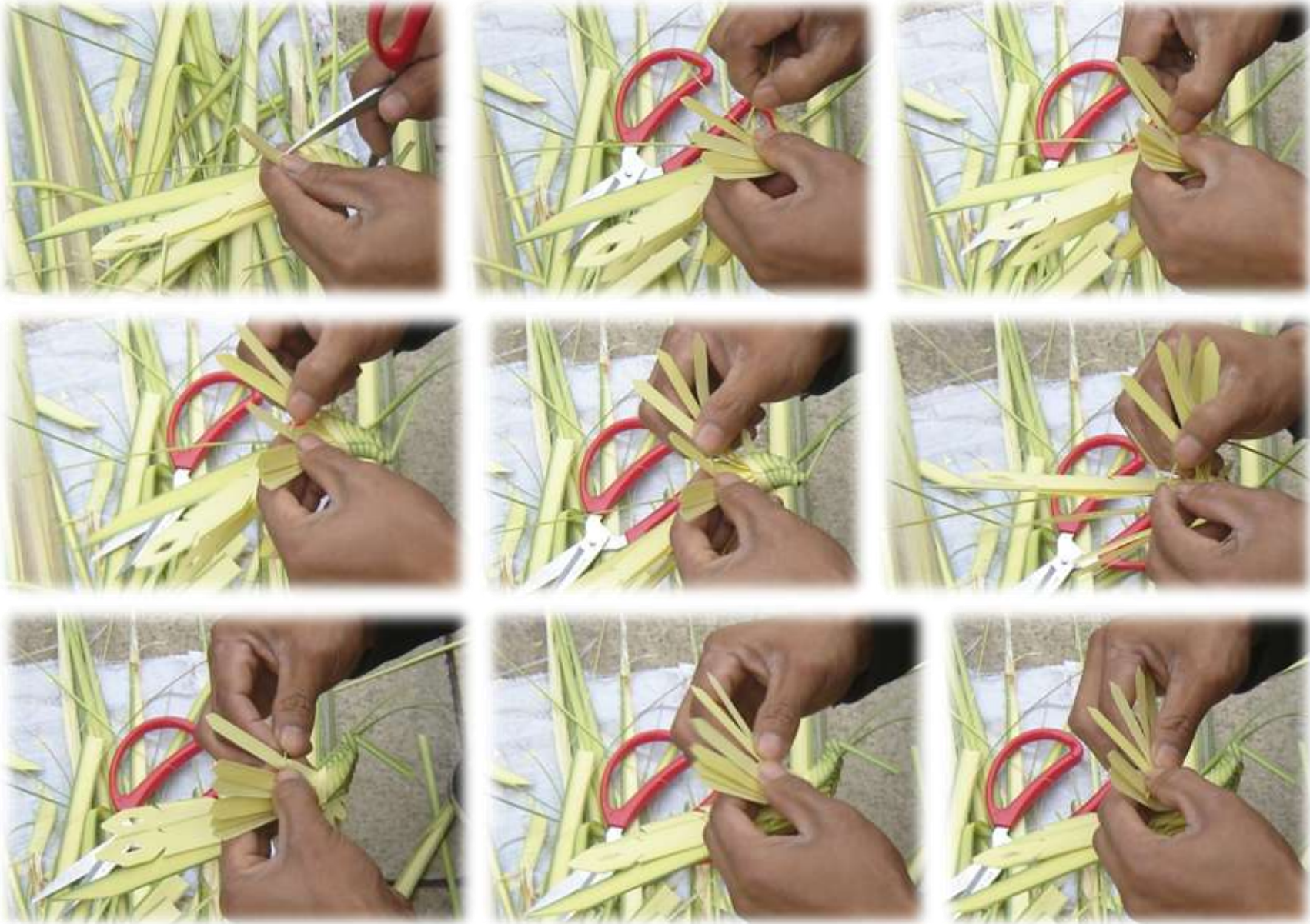







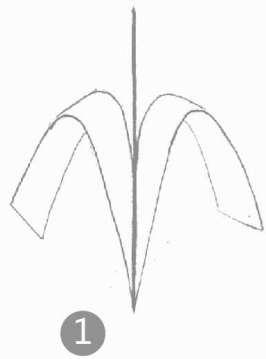

1

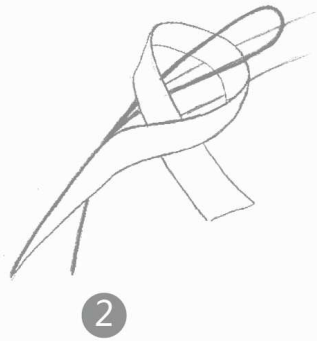

2



3

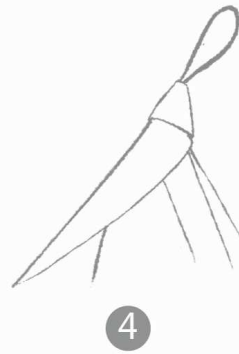

4



5



6

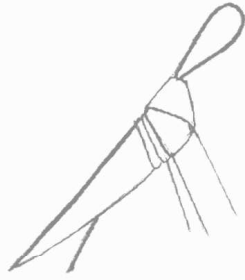

7 Repeat step 5-6 for three times

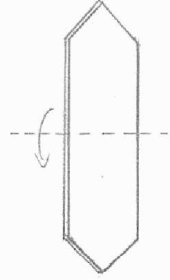

8 Shape out two pieces of leaf as shown above and fold them into half

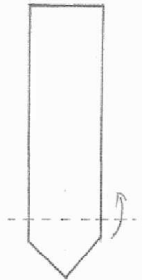

9 Fold along the dotted line

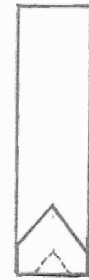

10 Cut it along the dotted lines



11 Cut out the shapes as the picture shown

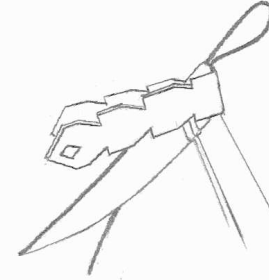

12

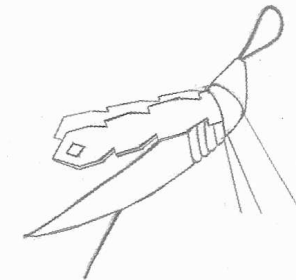

13 Repeat step 5-6 for two times

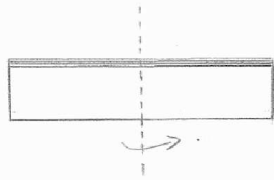

14 Shape out five pieces of leaves as shown above and fold them into half

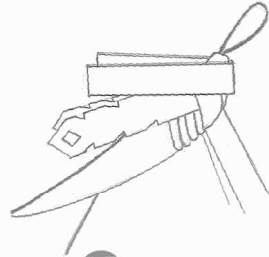

15

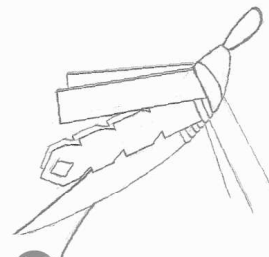

16 Repeat step 5-6 for two times



17 Cut out two pieces of leaves as shown above

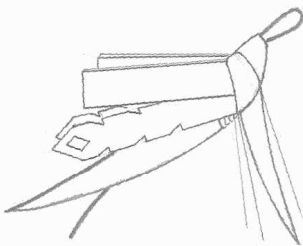

18 Repeat step 5-6 for two times

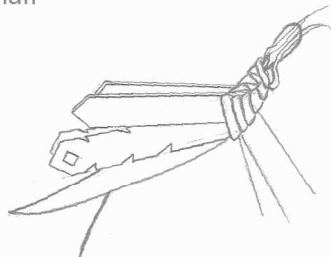

19 Insert the end of strips inside the rolled midrib then tight the rolled midrib

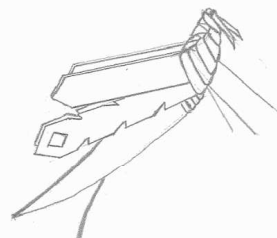

20 Tighten the leaf stalk



21 Cut out the shape of head

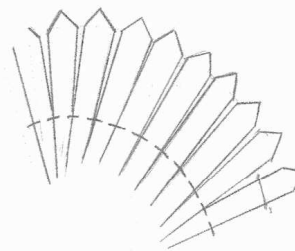

22 Spread out the tail with leaf stalk

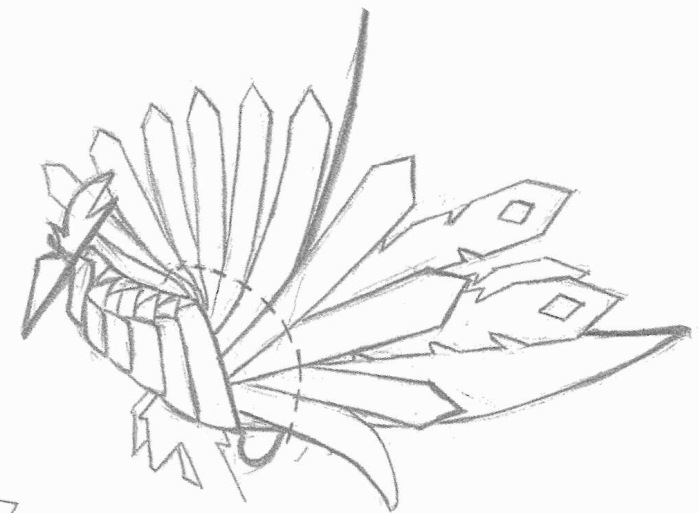

Peacock

Let's make the Grasshopper

This is a step by step guide to make a Grasshopper with palm leaf.

1- Cut the leaf of palm as same as the picture to make the Grasshopper's body and split half of the midrib of leaf.

2- Start with the middle of the leaf strips.

3- Take the midrib of the leaf to roll it into a circle and tie the two strips of the leaf on midribs one by one on the rolled midrib to develop the shape of a Grasshopper body.

4- After a couple of 5 ties, prepare 2 strips and fold them from the middle then put them on the body of Grasshopper (for the purpose of wings) and tie the main two strips . After two ties, prepare 1 strip and fold them from the middle then put it on the body of the Grasshopper (for the purpose of legs) and tie the main two strips to finish the form of Grasshopper body.

5 - Cut the tail of the Grasshopper.

6- While one hand is working, make sure the other hand is holding the body part. Never let it go, or it will become loose.

7- Shape the next strip with scissors to form of

如何织出蚱蜢

以下是利用棕榈叶制作蚱蜢的步骤。

1 -如图所示裁切棕榈片来制作蚱蜢的身体，将叶中脉劈开一半。

2 -从树叶的中部开始。

3 -将叶的中脉卷成一个圈，将两片树叶分别依次与卷好的中脉打结系在一起，做出蚱蜢身体的形状。

4 -在打了 5 组结后，准备 2 片树叶，从中间折叠它们，然后放在蚱蜢的身体上（作为两翼），并用主体的两片树叶打结系紧。在打了两个结后，准备 1 片树叶，从中部折叠，然后放在蚱蜢的身体上（作为腿），并用主体的两片树叶打结系紧，完成蚱蜢身体的形态。

5 -剪出蚱蜢的尾巴形态。

6 -当一只手在制作时，保证另一只手是握紧身体部分的。不要让它滑动或松动。

روش ساخت ملخ

توضیحات زیر یک راهنمای گام به گام برای ساختن یک ملخ از برگ نخل می باشد.

۱- مطابق تصویر برگ نخل را برای ساخت بدن ملخ برش زده و نیمی از رگ میانی برگ را جدا کنید.

۲- از وسط برگ شروع کنید.

۳- رگ میانی برگ را شبیه دایره پیچانده و برای فرم دادن بدن ملخ دو نوار برش زده را یکی یکی به دور رگ میانی انحناء داده شده گره بزنید.

۴- پس از ایجاد کردن پنج جفت گره، دو عدد نوار را از قسمت وسط تا کنید و سپس روی بدن ملخ قرار دهید (به عنوان بالهای آن) و دو نوار اصلی را گره بزنید. دوباره پس از زدن یک جفت گره، یک عدد نوار را آماده کرده و آن را از قسمت وسط تا نموده و سپس روی بدن ملخ قرار دهید (به عنوان پاهای آن) و دو نوار اصلی را گره زده تا مرحله شکل گیری بدن ملخ پایان یابد.

۵- قسمت دم ملخ را برش بزنید.

۶- هنگامیکه با یک دست خود مشغول کار هستید، با دست دیگر خود قسمت بدن را نگه داشته و به هیچ عنوان آن را رها نکنید.

۷- برای فرم دادن پاها بوسیله قیچی نوار بعدی را برش بزنید.

۸- در این مرحله، بالها را با دست خود فرم دهید.

legs.

8- Shape the wings by hand.

9- With the remaining parts of the main strips make the head and put it inside the rolled midrib and tighten it.

7-用剪刀对树叶塑形，修剪出腿。

8-用手调整，塑造出翅膀的形态。

9-用主体树叶的剩余部分做成头部，放入卷成圈的中脉中并固定紧。

۹- از باقیمانده نوارها قسمت سر را ساخته و در قسمت رگ

میانی پیچانده شده قرار دهید و سپس آن را گره بزنید.

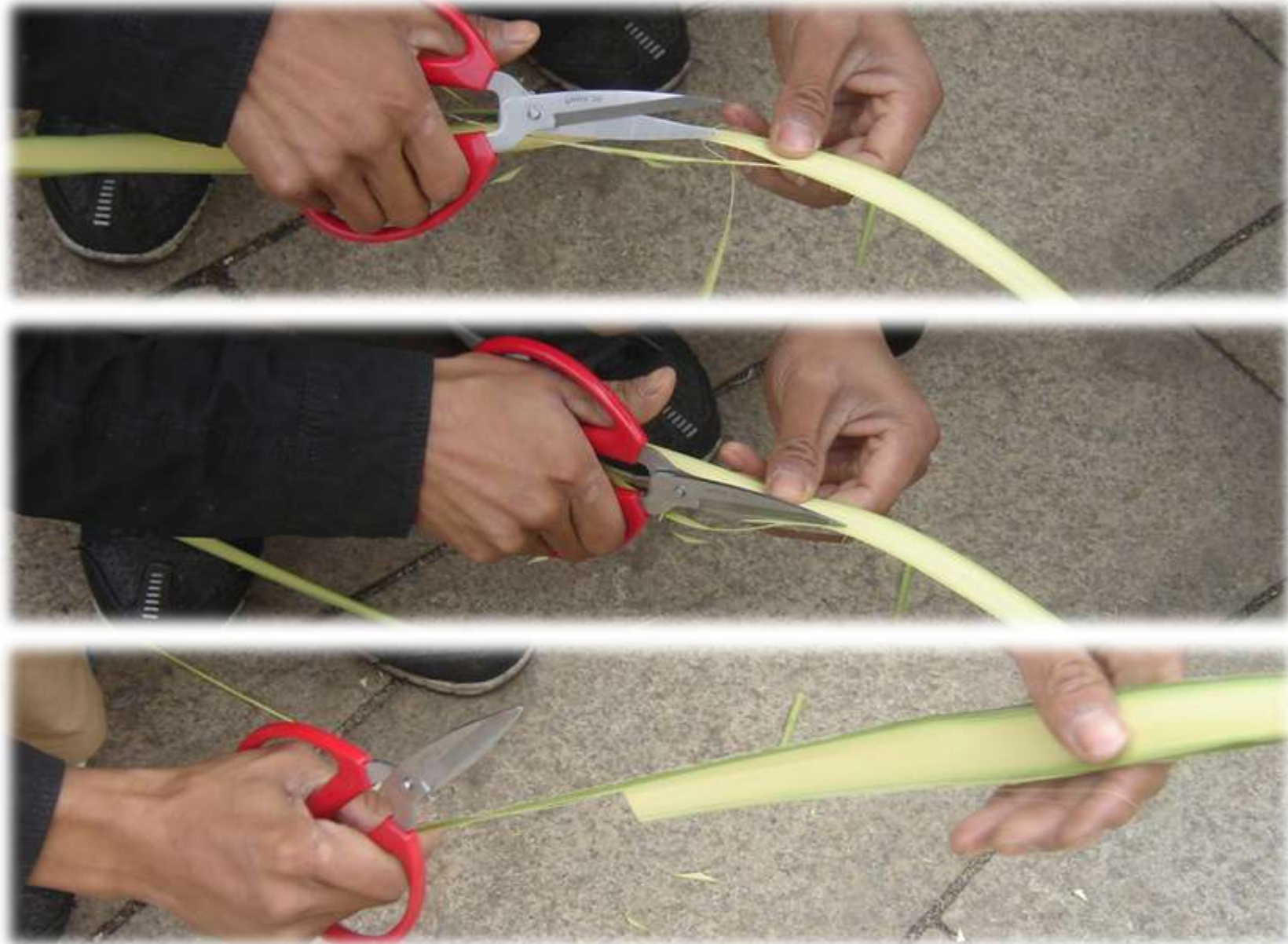



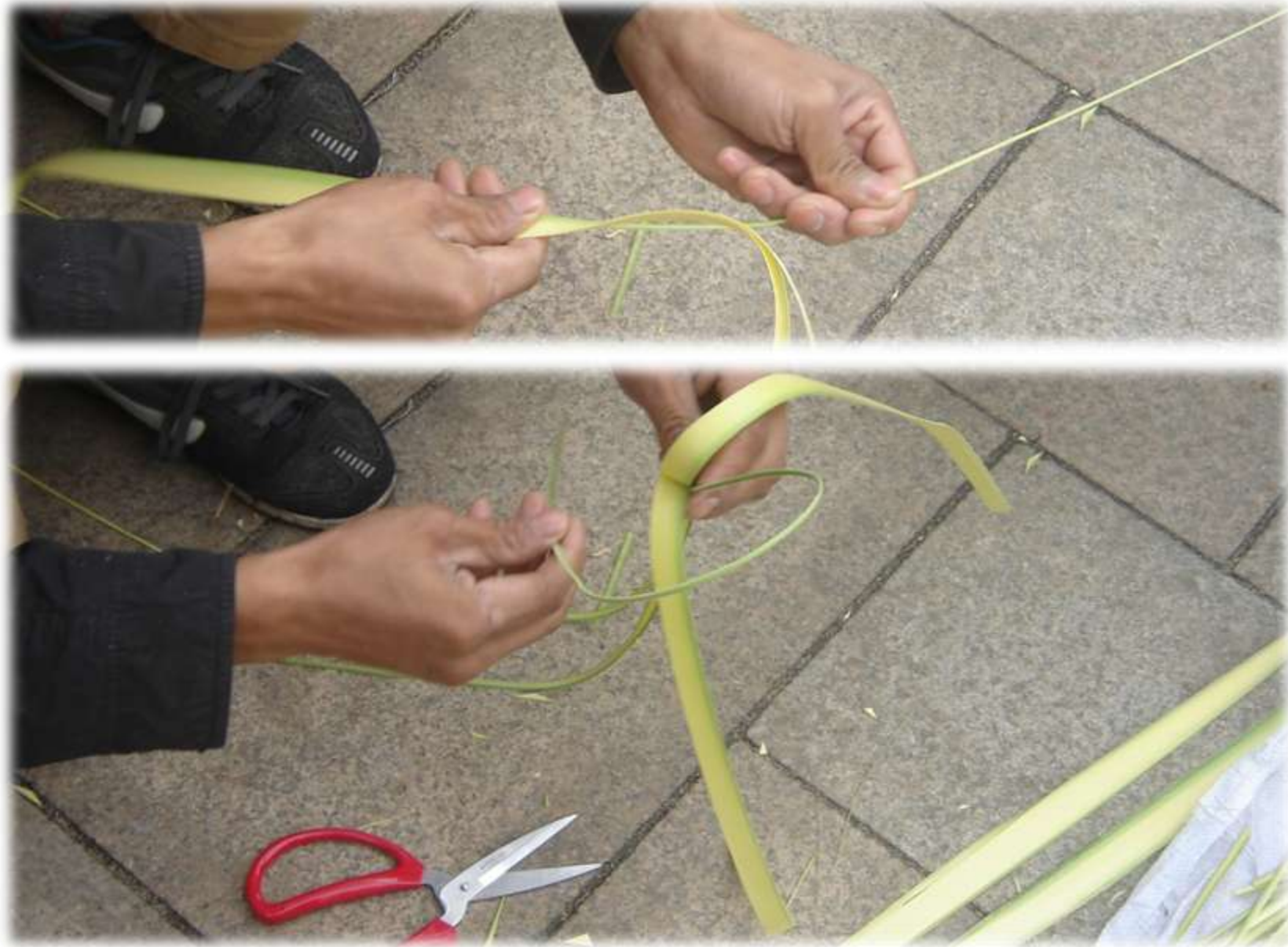

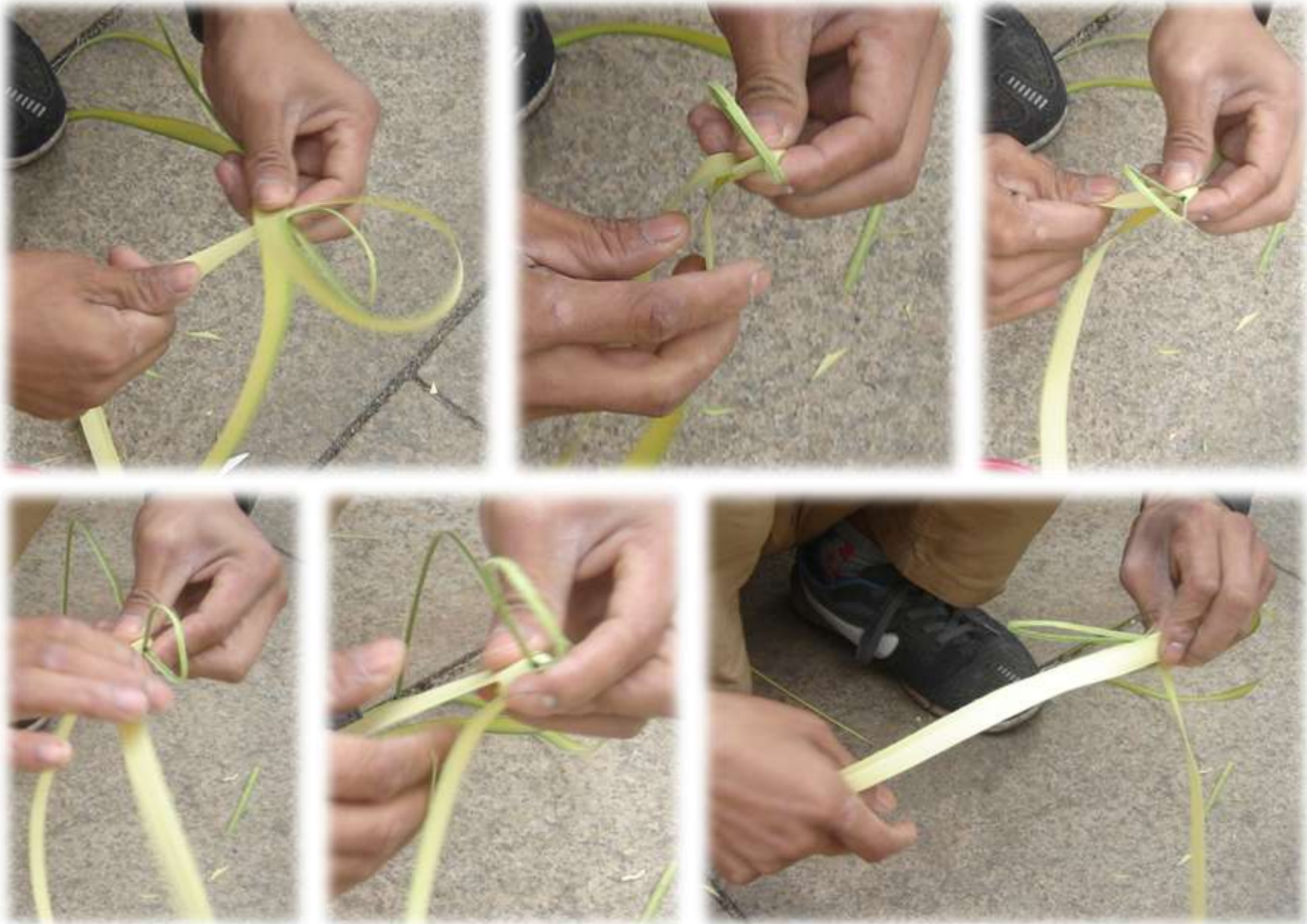



















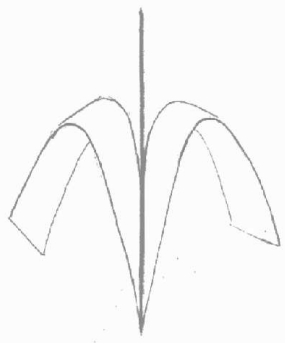

1

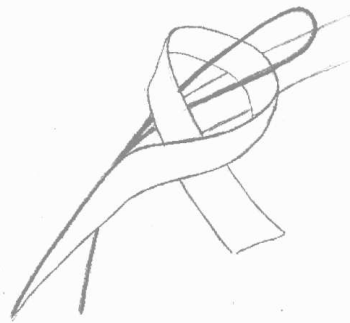

2

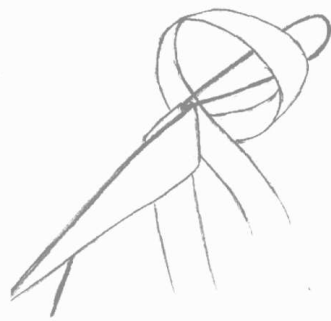

3



4

After completion of step 2&3 we will acquire this shape



5



6

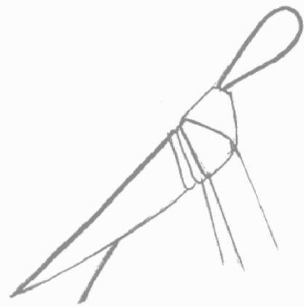

7

Repeat step 5-6 for three times

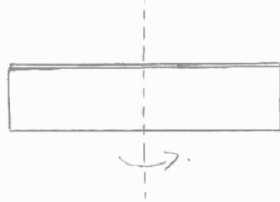

8

Cut two pieces of leaf and fold them into half

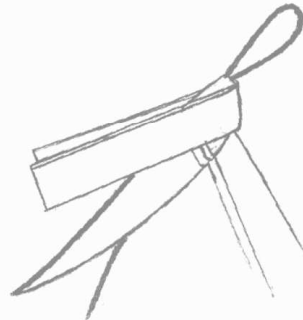

9



10

Repeat step 5&6 for two times

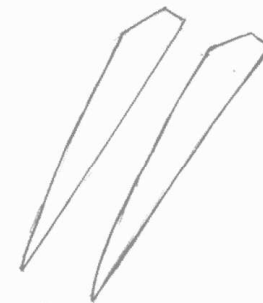

11

Shape out two pieces of leaves as shown above

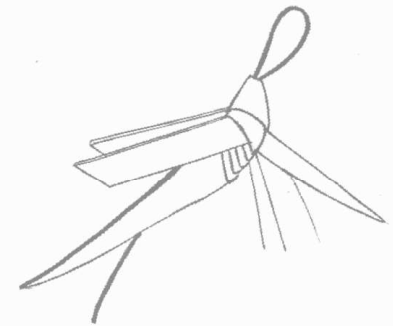

12

Add the leaves as the picture shown

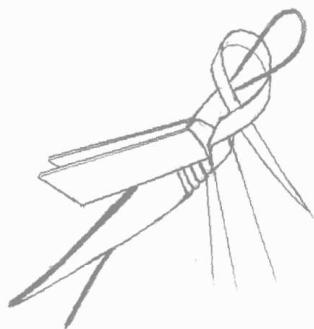

13

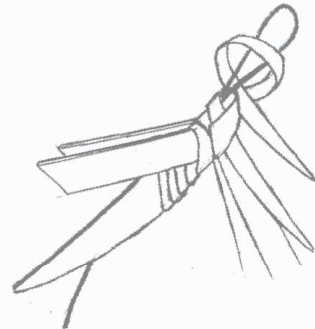

14

Repeat step 13-14 for two times



15



16

Do as the picture shown to achieve the toy's head

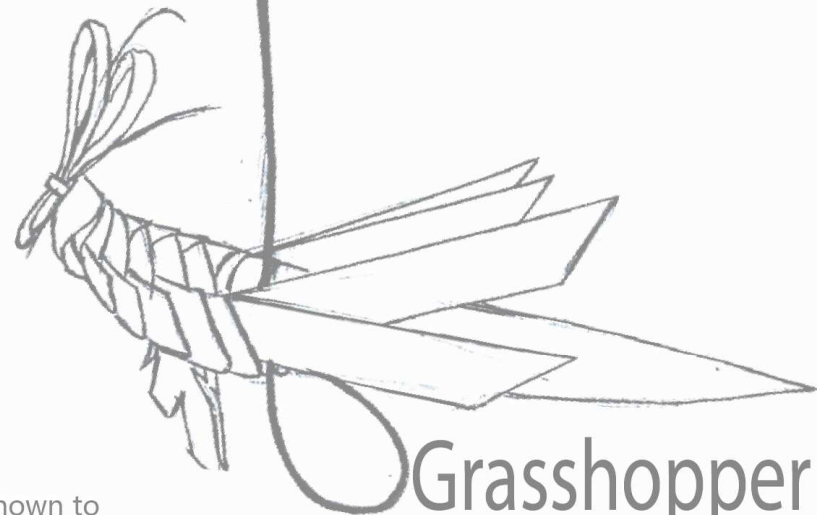

Grasshopper

Let's make the Dragonfly

This is a step by step guide on making a Dragonfly with palm leaf.

1- Cut the leaf of palm similar to the picture to make the Dragonfly and split half till the midrib of the leaf.

2- Start with the middle of the leaf strips.

3- Take the midrib of the leaf and roll it into a circle, then tie the two strips of the leaf on the midribs one by one on the rolled midrib to make the shape of a Dragonfly body.

4- After a couple of ties, prepare 2 strips and fold them from the middle then put them on the body of the Dragonfly (for the purpose of the wings) and tie the main two strips. After two ties, prepare a strip and fold them from the middle then put it on the body of the Dragonfly (for the purpose of the legs) and tie the main two strips to finish the form of a Dragonfly body.

5- Shape the tail of the Dragonfly by using the scissors.

6- While one hand is working, make sure the other hand is holding the body part. Never let it

如何织出蜻蜓

以下是利用棕榈叶制作蜻蜓的步骤。

1-如图所示裁切棕榈片来制作蜻蜓的身体，将叶中脉劈开一半。

2-从树叶的中部开始。

3-将叶的中脉卷成一个圈，将两片树叶分别依次与卷好的中脉打结系在一起，做出蜻蜓身体的形状。

4-在打了 1 组结后，准备 2 片树叶，从中间折叠，然后放在蜻蜓的身体上（作为两翼），并用主体的两片树叶打结系紧。在打了 2 组结后，准备 1 片树叶，并从中间折叠，然后放在蜻蜓的身体上（作为腿），并用主体的两片树叶打结系紧，完成蜻蜓身体的形态。

5-用剪刀修剪蜻蜓的尾巴。

6-当一只手在制作时，保证另一只手是握紧身体部分的。不要让它滑动或松动。

روش ساخت سنجاقک

توضیحات زیر یک راهنمای گام به گام برای ساختن یک سنجاقک از برگ نخل می باشد.

۱- مطابق تصویر برگ نخل را برای ساخت سنجاقک برش زده و نیمی از رگ میانی برگ را جدا کنید.

۲- از وسط نوار برگ برش خورده شروع کنید.

۳- رگ میانی برگ را شبیه دایره پیچانده و برای فرم دادن بدن سنجاقک دو نوار را یکی یکی به دور رگ میانی انحنا داده شده گره بزنید.

۴- پس از ایجاد کردن سه جفت گره، دو عدد نوار را از قسمت وسط تا کنید و سپس روی بدن سنجاقک قرار دهید (به عنوان بالهای آن) و دو نوار اصلی را گره بزنید. دوباره پس از زدن یک جفت گره، یک عدد نوار را آماده کرده و آن را از قسمت وسط تا نموده و سپس روی بدن سنجاقک قرار دهید (به عنوان پاهای آن) و دو نوار اصلی را گره زده تا مرحله شکل گیری بدن سنجاقک پایان یابد.

۵- قسمت دم سنجاقک را برش بزنید.

۶- هنگامیکه با یک دست خود مشغول کار هستید، با دست دیگر خود قسمت بدن را نگه داشته و به هیچ عنوان آن را رها نکنید.

۷- برای فرم دادن پاها بوسیله قیچی نوار بعدی را برش بزنید.

۸- بوسیله نوک نیز قیچی روی بالها سوراخ ایجاد کرده تا بتوانید از طریق این سوراخها، باریکه ای برش زده از قسمت

go, or it will become loose.

7- Shape the next strip with scissors to form legs.

8- Pierce a hole on the wings with the point of the scissors to insert a stick. This time Shape the wings by hand.

9- Form the head with the remaining part of the palm leaf and put it inside the rolled midrib and tighten it.

7-用剪刀修剪树叶形成腿。

8-用剪刀的尖头在两翼上戳孔，插入一根棍子。并用手塑形翅膀。

9-用树叶的剩余部分做成头部，放入卷成圈的中脉中并固定紧。

رگ میانی برگ را عبور دهید. در این مرحله، بالها را با دست خود فرم دهید.

۹- از باقیمانده برگ قسمت سر را ساخته و در قسمت رگ میانی پیچانده شده قرار دهید و سپس آن را گره بزنید.







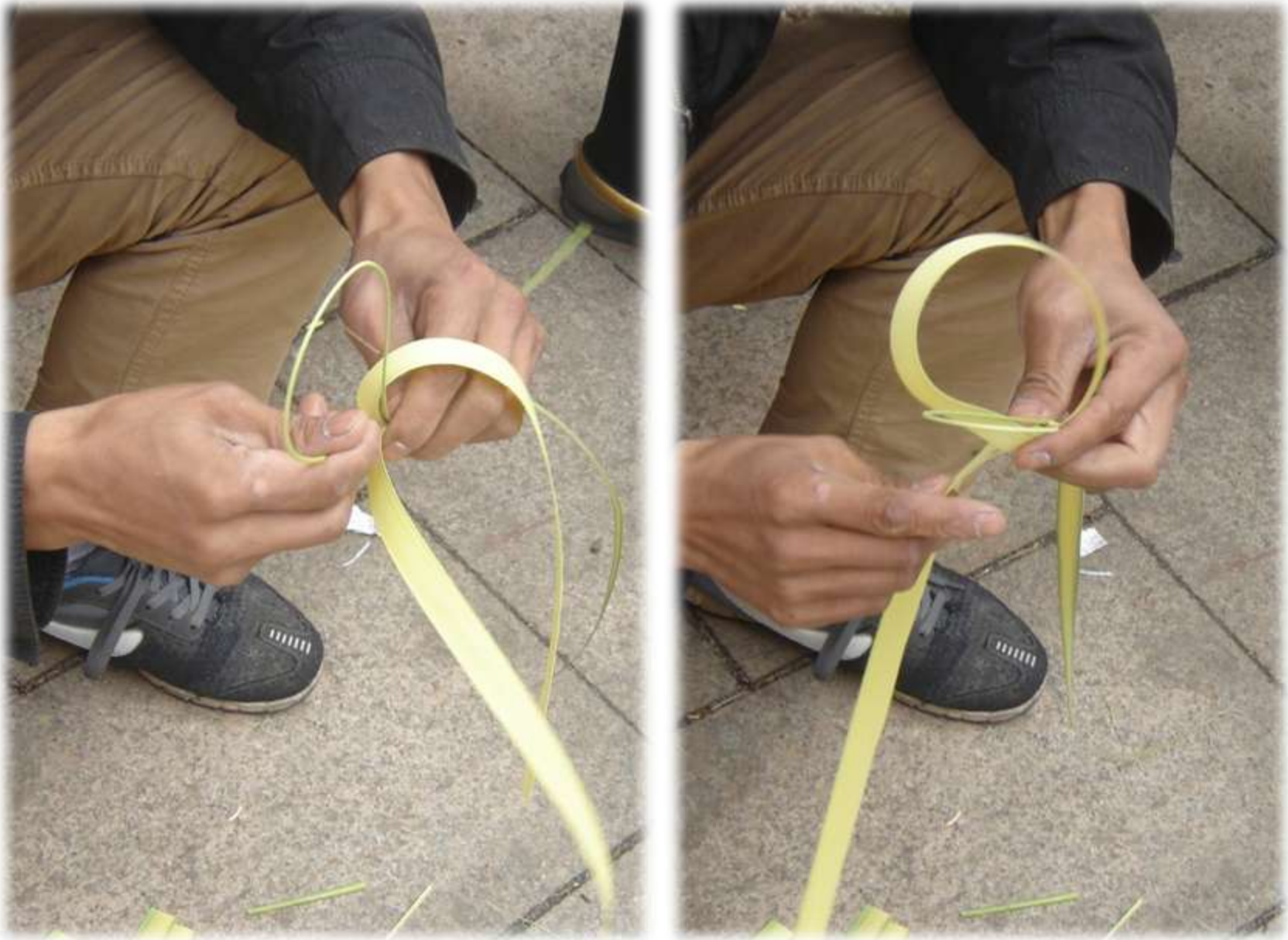





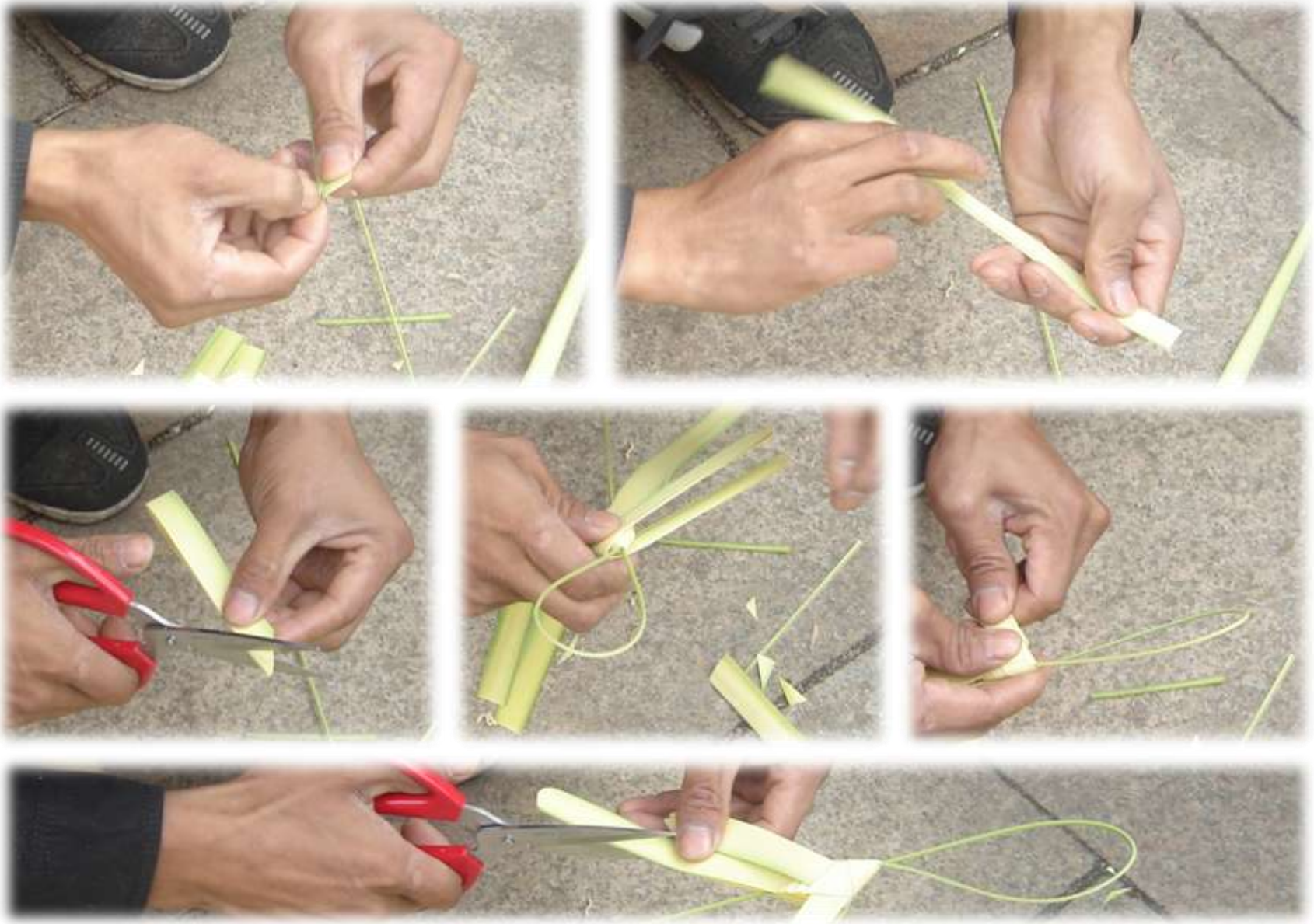

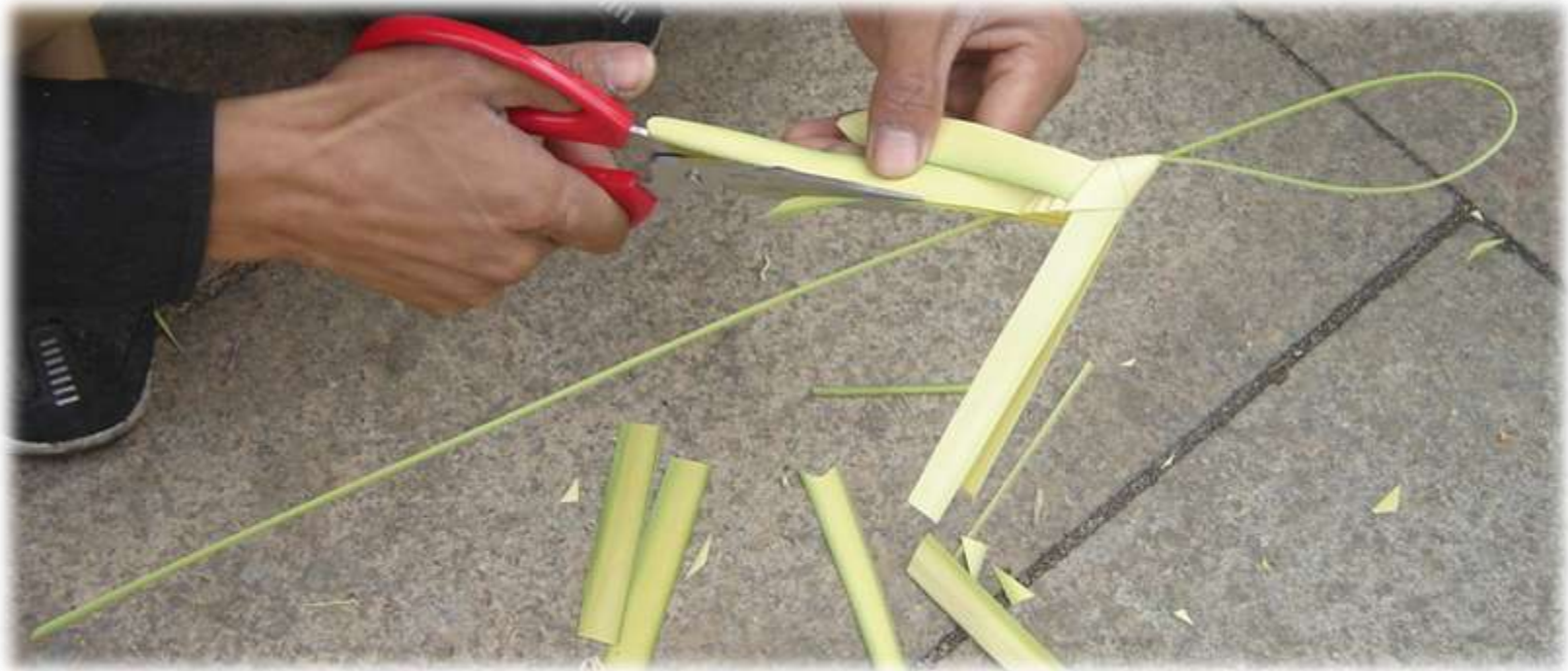





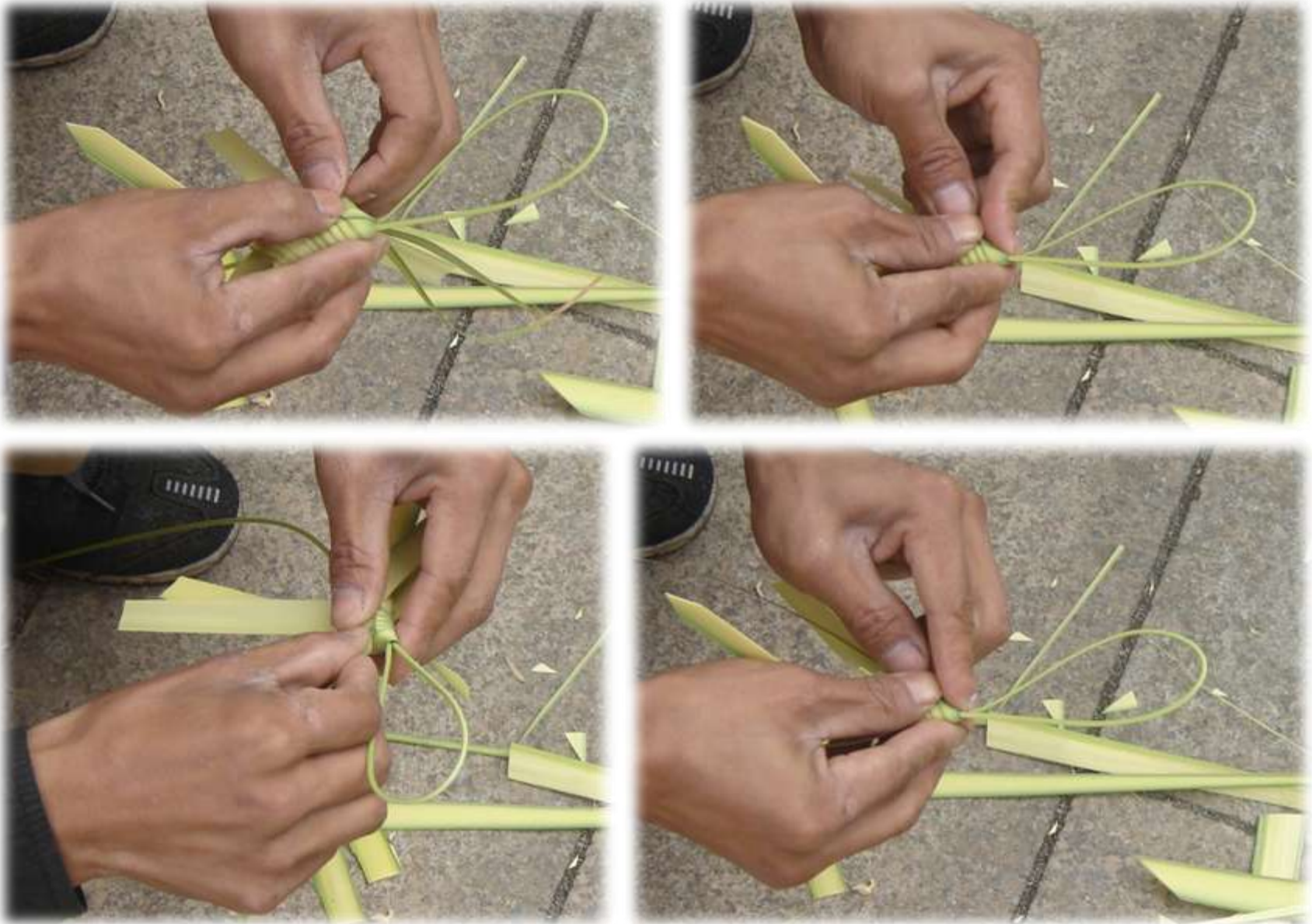









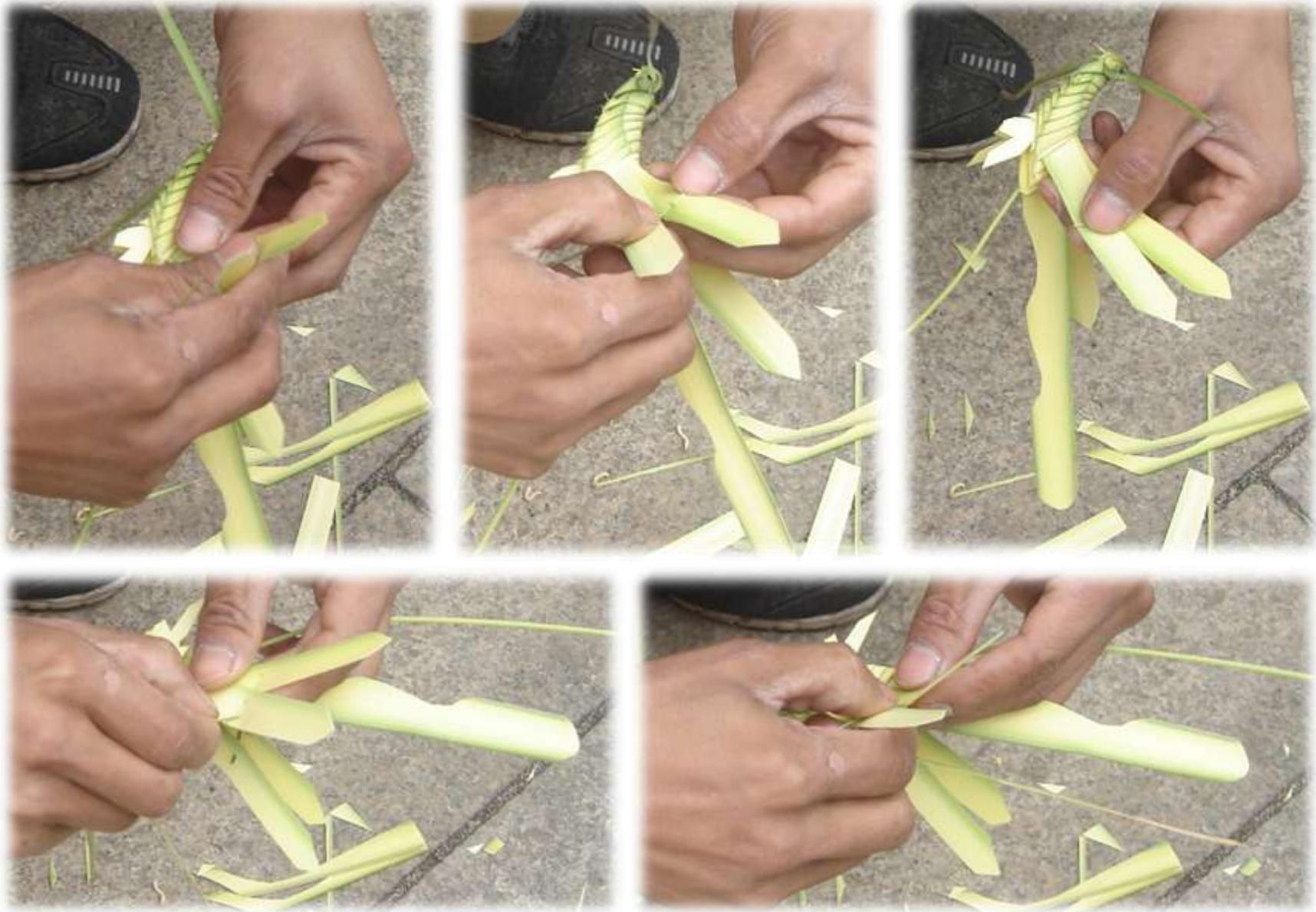







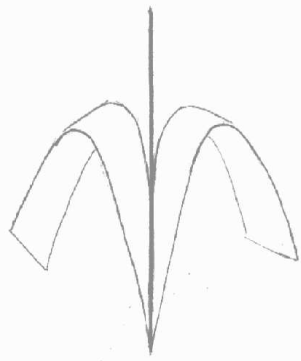

1

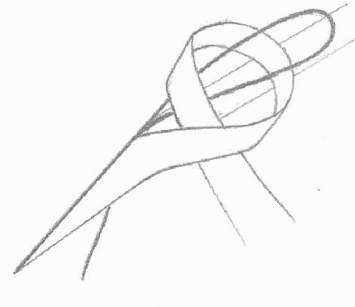

2



3

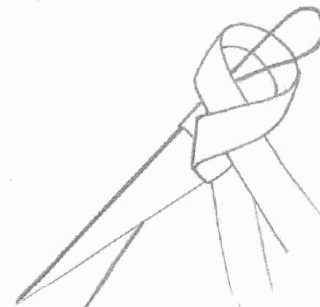

4

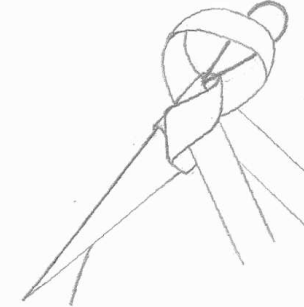

5

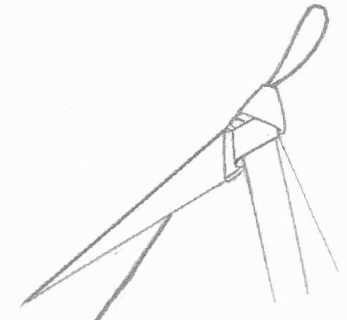

6

Repeat step 4-5 for one more time

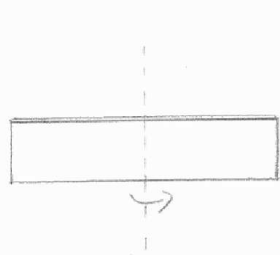

7

Cut two pieces of leaves as the picture shown above and fold them into half

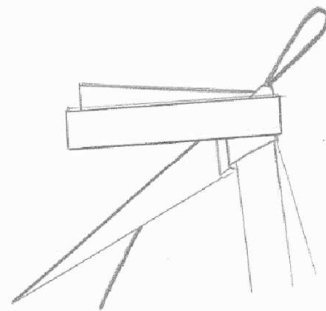

8

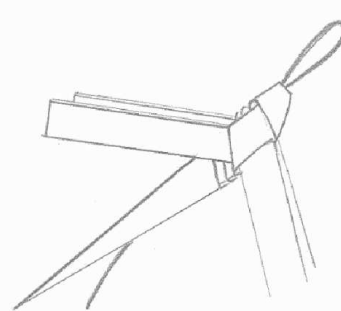

9

Repeat step 4-5 for one more time



10

Shape out two pieces of leaves a shown above

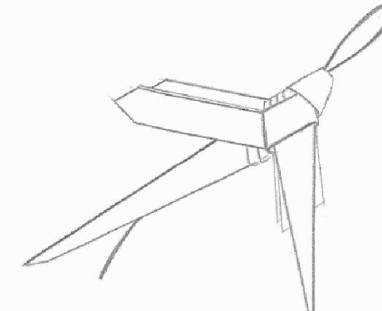

11

Insert the leaves as shown above

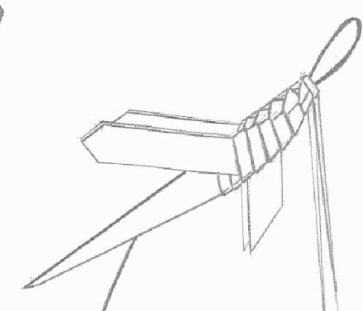

12

Repeat step 4&5 for 7 times

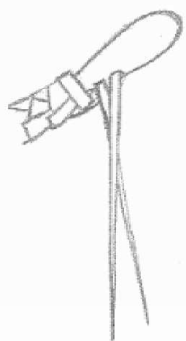

13

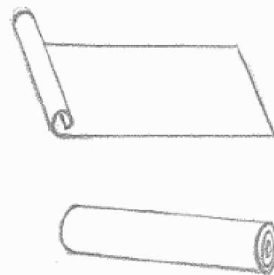

14

Cut a small piece of leaf and roll it up

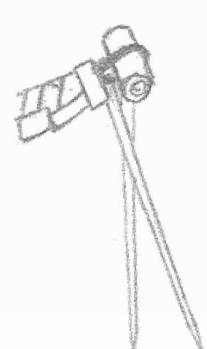

15

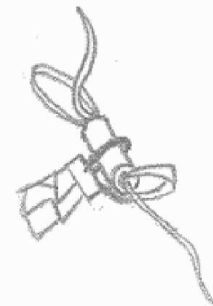

16

Tie the roll inside the little space kept with the thread



17

Spread out the tail with leaf stalks

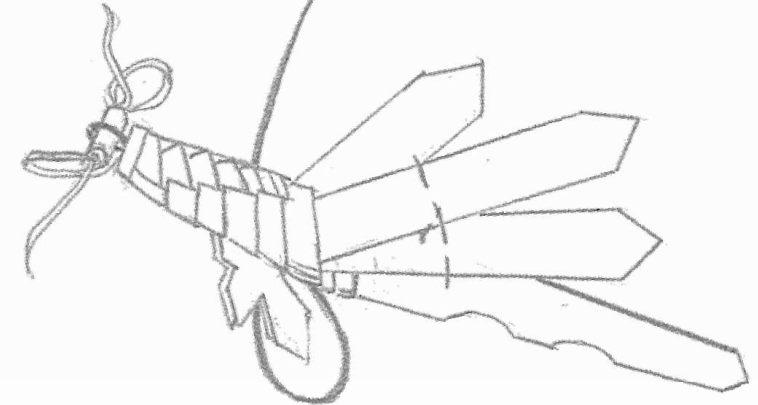

Dragonfly

Let's make the Bird

This is a step by step guide on making a Bird with palm leaf.

1- Cut the leaf of palm similar to the picture to make the Bird and split half of the midrib of leaf.

2- Start with the middle of the leaf strips.

3- Take the midrib of leaf to roll it into a circle.

4 - Tie the two strips of leaf on midribs one by one on the rolled midrib to make the shape of a Bird body.

Put the end of the strips which is narrow in the rolled part of midrib to present the head.

5- While one hand is working, make sure the other hand is holding the body part. Never let it go, or it will become loose.

6- Prepare 2 feathers (for purpose of wings) out of palm leaf.

7- Pierce a hole on body by sharpness of scissors to put the wings, in this time Shape the wings by hand.

8- Make a hand grip out of the remaining midrib.

如何织出小鸟

以下是利用棕榈叶制作小鸟的步骤。

1 -如图所示裁切棕榈片来制作小鸟的身体，将叶中脉劈开一半。

2 -从树叶的中部开始。

3 -将叶的中脉卷成一个圈。

4 -逐一将 2 片树叶，与卷成圈的中脉打结系紧，形成小鸟的身体。将树叶的最窄的尾端放入卷起的中脉中，形成小鸟的头。

5 -当一只手在制作时，保证另一只手是握紧身体部分的。不要让它滑动或松动。

6-用另外的棕榈叶准备两片羽毛（作为两翼）。

7-用剪刀的尖头在身体上戳一个孔，放入两翼。并用手塑形翅膀。

8-用剩余的中脉做出一个手柄。

روش ساخت پرنده

توضیحات زیر یک راهنمای گام به گام برای ساختن یک پرنده از برگ نخل می باشد.

۱- مطابق تصویر برگ نخل را برای ساخت پرنده برش زده و نیمی از برگ را جدا کنید.

۲- از وسط نوار برگ برش خورده شروع کنید.

۳- رگ میانی برگ را شبیه دایره ببیچانید.

۴- برگ را شبیه دایره پیچانده و برای فرم دادن بدن پرنده دو نوار برش خورده را یکی یکی به دور رگ میانی انحنا داده شده گره بزنید. برای فرم دادن سر، انتهای باریک نوارها را درون رگ میانی پیچیده شده بگذارید.

۵- هنگامیکه با یک دست خود مشغول کار هستید، با دست دیگر خود قسمت بدن را نگه داشته و به هیچ عنوان آن را رها نکنید.

۶- از برگ نخل دو عدد پر (به عنوان بالهای آن) برش بزنید.

۷- بوسیله نوک تیز قیچی روی بالها سوراخ ایجاد کرده تا بتوانید از طریق این سواخها، نوار برگ برش خورده را عبور دهید. در این مرحله، بالها را با دست خود فرم دهید.

۸- در آخر از باقیمانده برگ دسته را بسازید.



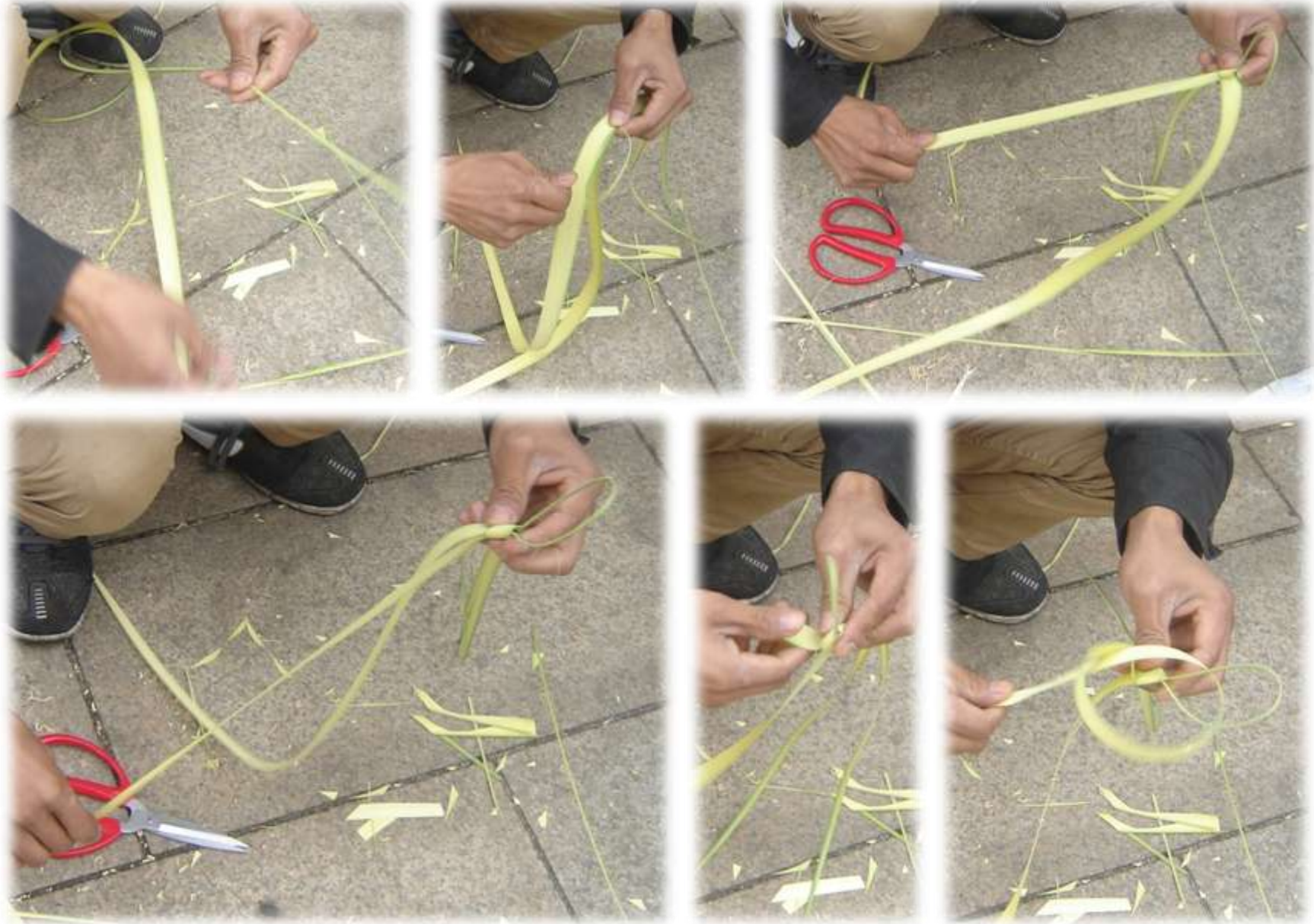

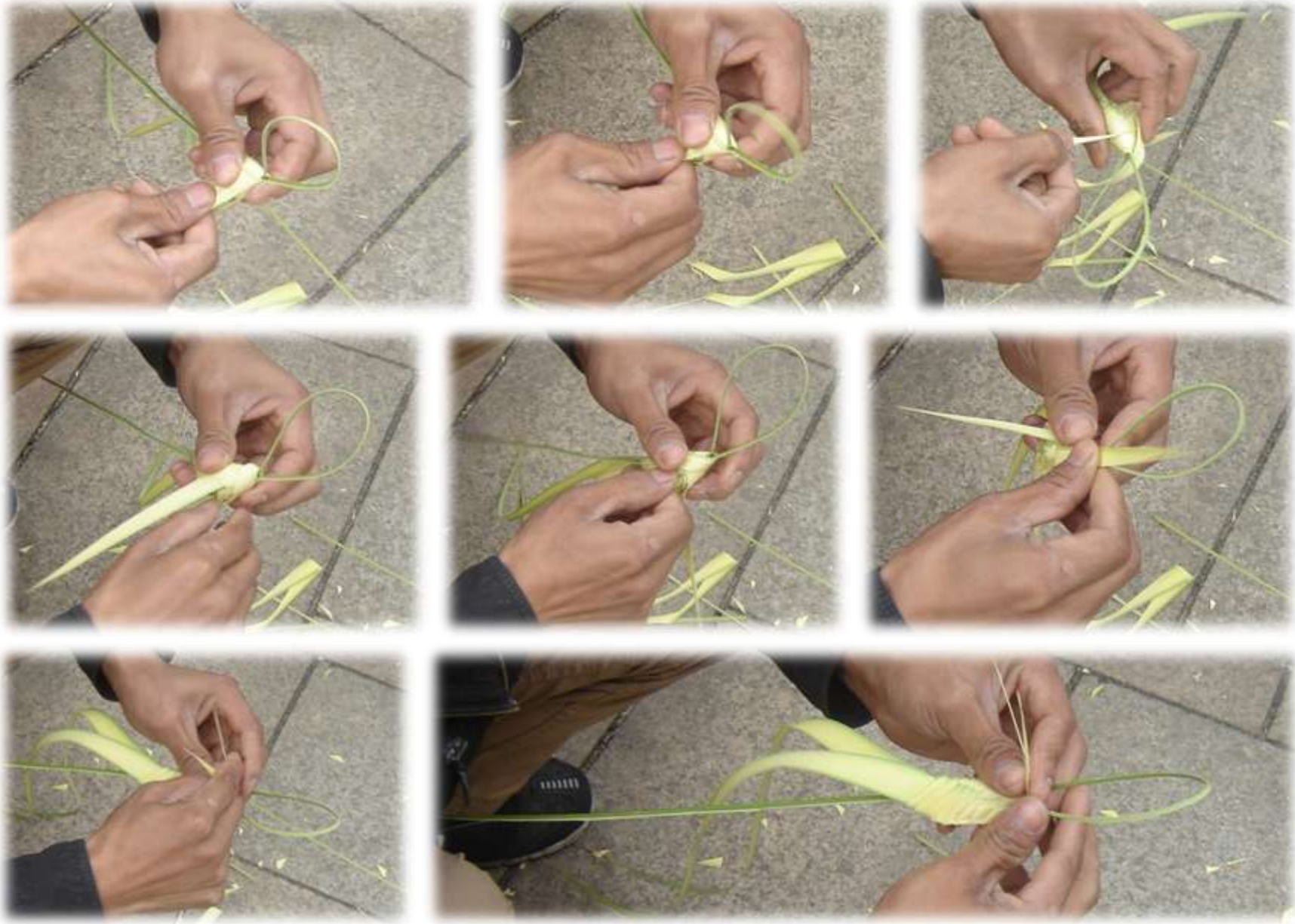



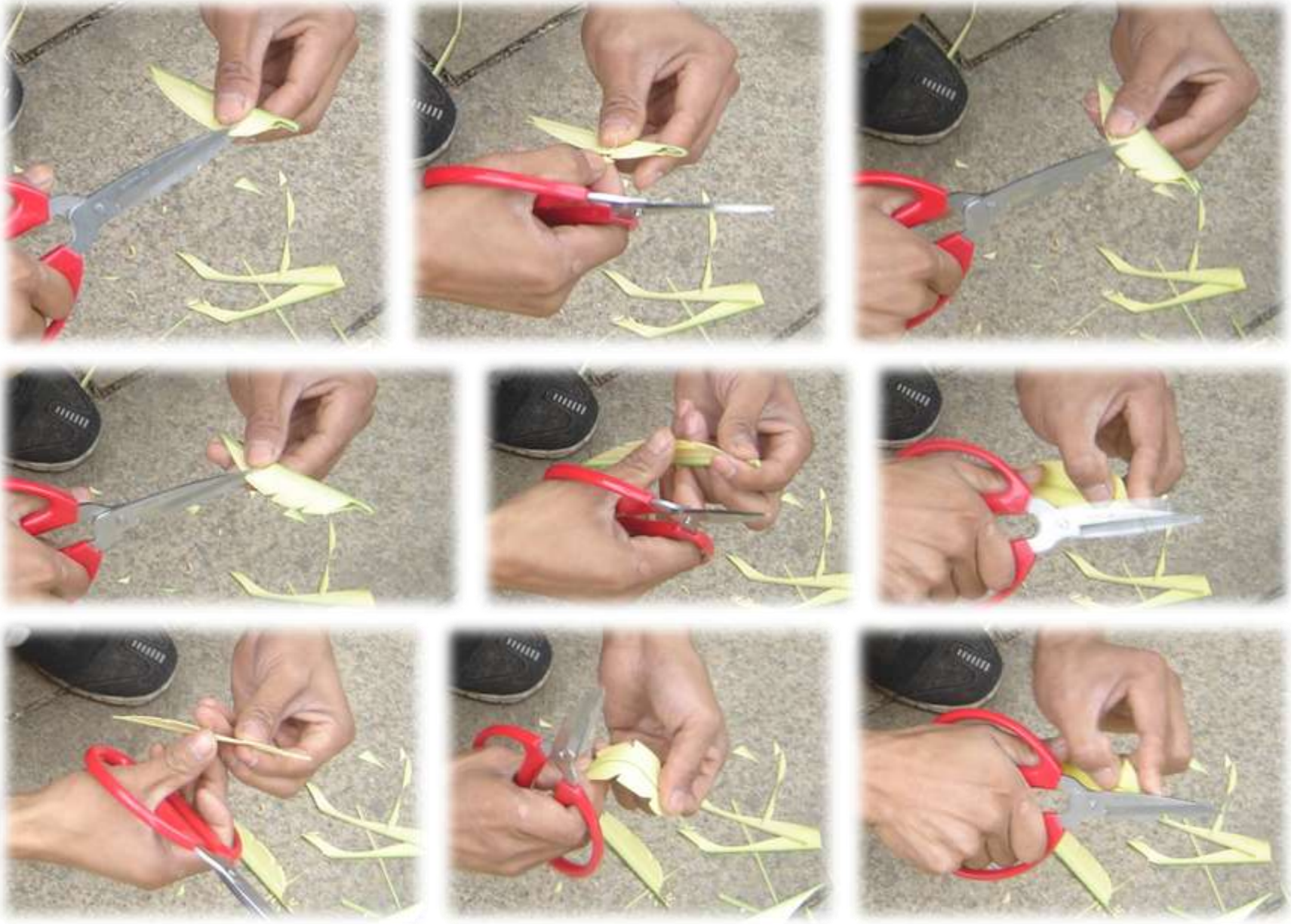





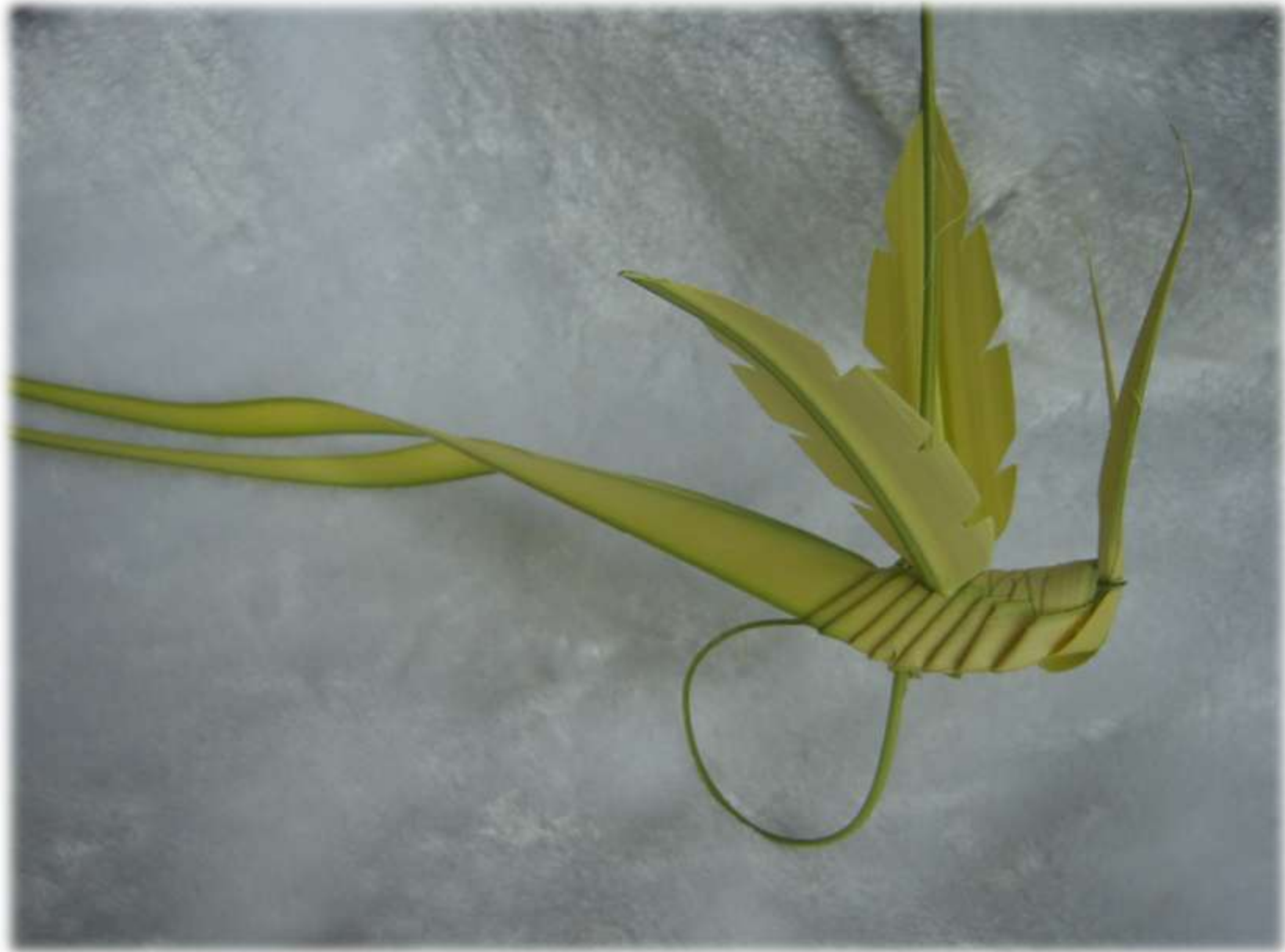

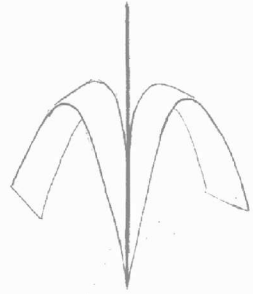

1

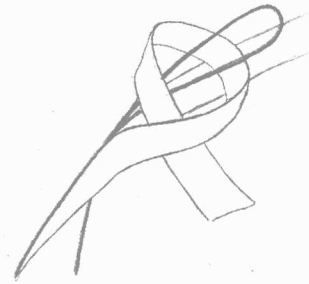

2

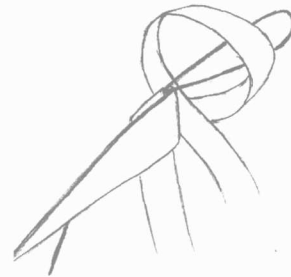

3

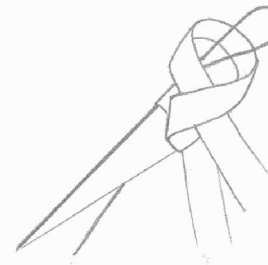

4

After completion of step 2&3 the leaf will acquire this shape



5



6

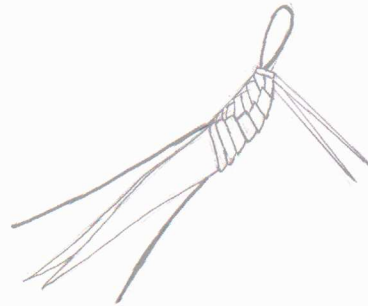

7

Repeat the step 5&6 for nine times after which you will get this shape. Separate the tails and leaf stalk

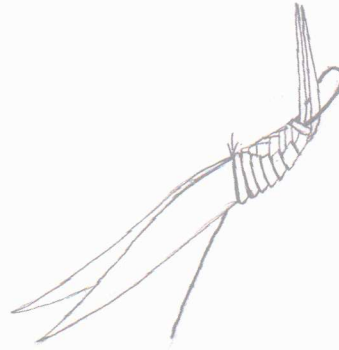

8

Insert the end of strips inside the rolled midrib then tight the rolled midrib

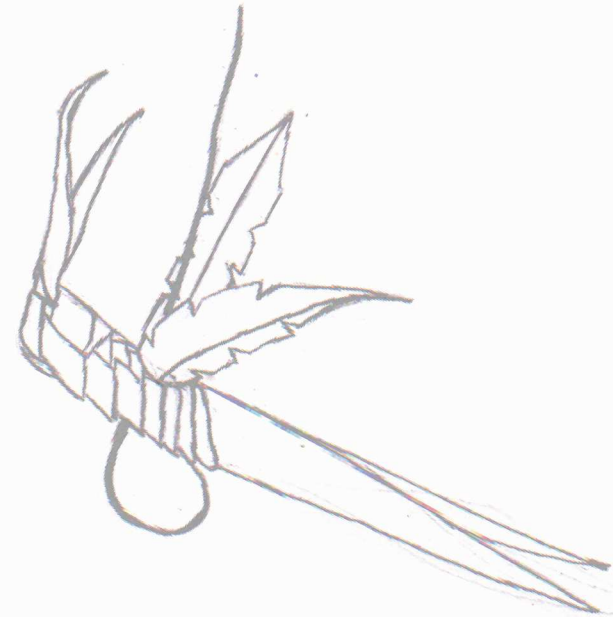

9

Take a piece of leaf and then bend it in between and cut both sides to make it acquire the shape of a feather.



10

Pierce a hole with scissors on the body of the bird and then insert the two feathers to make it look as if it is flying.



11

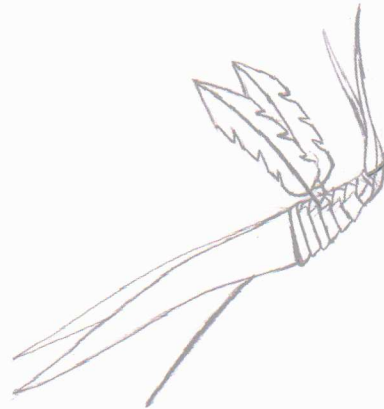

12

Pierce a hole with scissors, plug in the wings

Bird

Let's make the Frog

This is a step by step guide on making a frog with palm leaf.

- 1- Prepare 10 strips out of palm leaf similar to the picture to make the body of a frog.
- 2- Start on the middle of the leaf strips.
- 3- Take them and weave them one by one to make the shape of a frog's body.
- 4- While one hand is weaving, make sure the other hand is holding the weaved body. Never let it go, or it will become loose.
- 5- Keeping the top fold, weave the leaf strips to shape the stomach and month of frog.
- 6- Take the strips and weave the legs and hands.
- 7 – Cut the remain part of strips to shape the fingers.
- 8- Take a strip and tie one side of that.
- 9 – Cross the strip from face of the frog and tie it again to present the eyes.

如何织出青蛙

以下是利用棕榈叶制作青蛙的步骤。

- 1 –如图准备十片棕榈叶来制作青蛙的身体。
- 2 -从树叶的中部开始。
- 3 –拿着棕榈叶，一片一片地进行编织，做出青蛙的身体。
- 4 –当一只手在编织时，保证另一只手是握紧已编织的身体部分的。不要让它滑动或松动。
- 5 – 逐渐塑形成一只青蛙。保持顶部合拢，并编织出青蛙的腹部和嘴。
- 6 – 再拿树叶编织出后肢和前肢。
- 7 – 剪掉树叶的多余部分形成手指。
- 8 –拿一片树叶系紧一头。
- 9 –从青蛙的脸部穿过树叶，并再次系紧，完成眼睛的制作。

روش ساخت قورباغه

توضیحات زیر یک راهنمای گام به گام برای ساختن یک قورباغه از برگ پالم می باشد.

- ۱- مطابق تصویر از برگ پالم ۱۰ عدد نوار را برای ساخت بدن قورباغه برش بزنید.
- ۲- از وسط برگ شروع کنید.
- ۳- یکی یکی آنها را بافته تا فرم بدن ساخته شود.
- ۴- هنگامیکه با یک دست خود مشغول کار هستید، با دست دیگر خود قسمت بدن بافته شده را نگه داشته و به هیچ عنوان آن را رها نکنید.
- ۵- همزمانکه قسمت بافته شده بالایی را نگهداشته اید، نوار برگ برش خورده را بافته تا شکم و دهان قورباغه ساخته شود.
- ۶- از نوار برگ برش خورده پاها و دستها را بیافید.
- ۷- قسمت باقیمانده نوارها را برای ساختن انگشتان برش بزنید.
- ۸- یک نوار را برداشته و یک سمت آن را گره بزنید.
- ۹- برای نشان دادن چشمها، نوار را از سر قورباغه عبور داده و آن را دوباره گره بزنید.



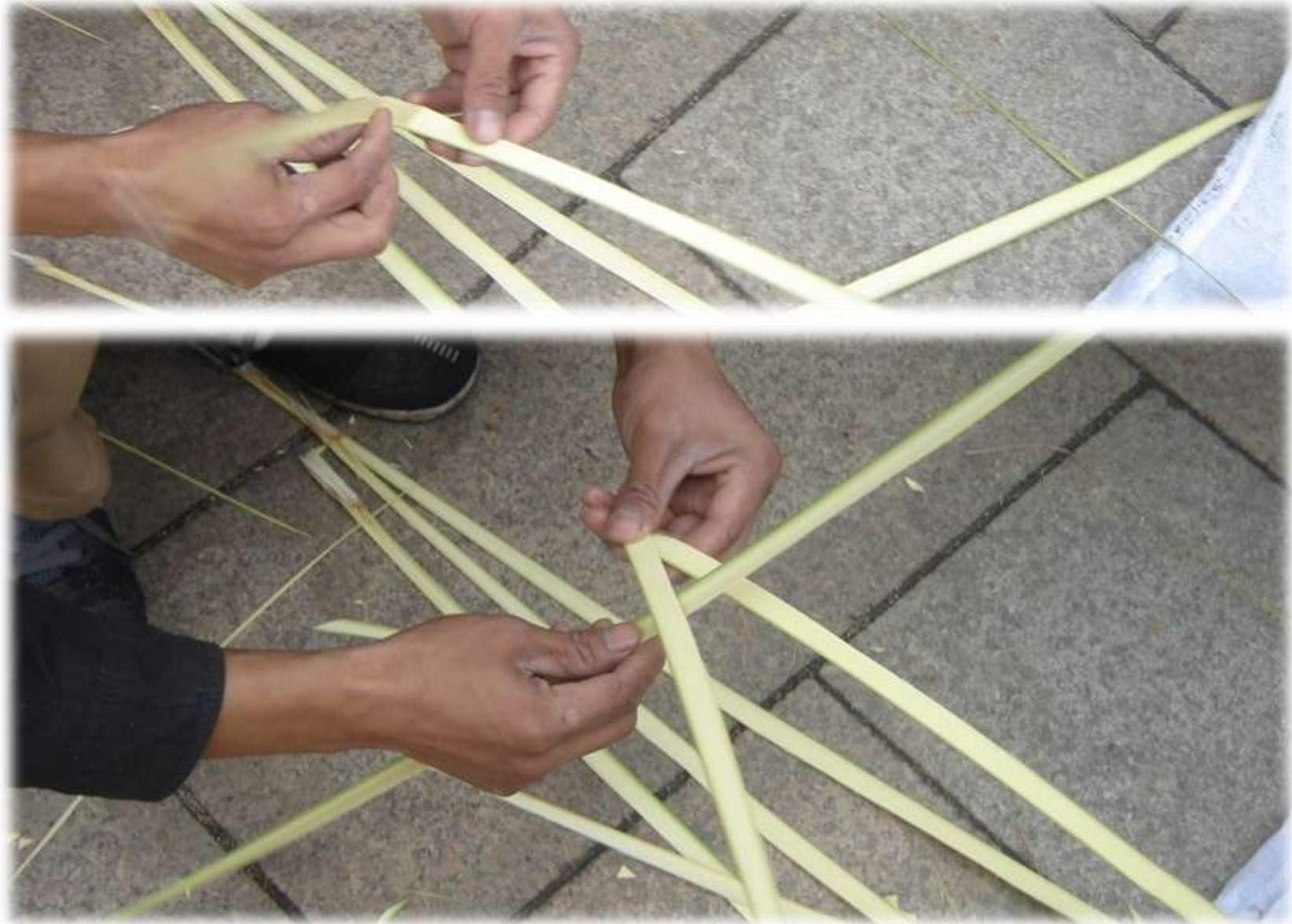

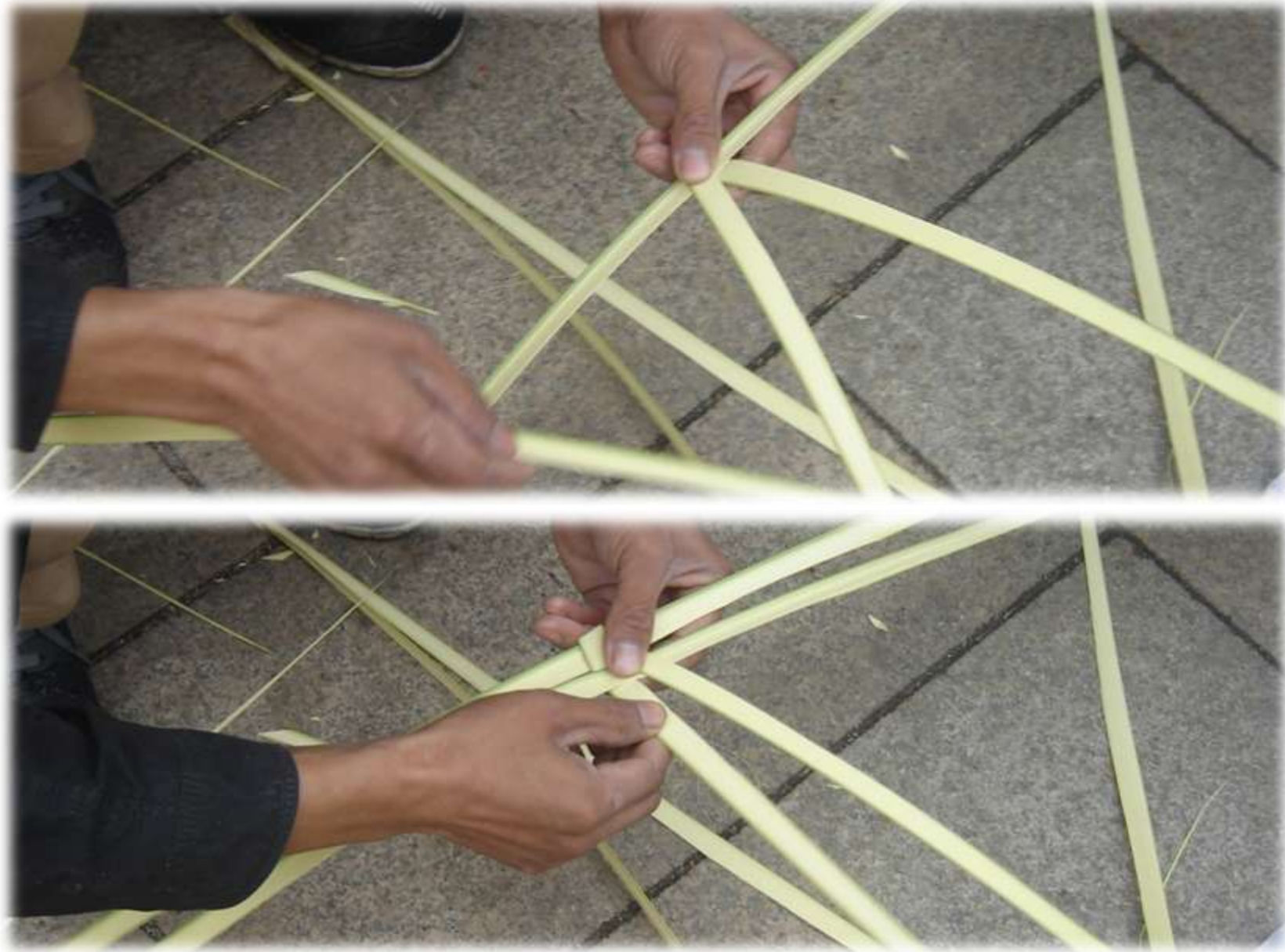

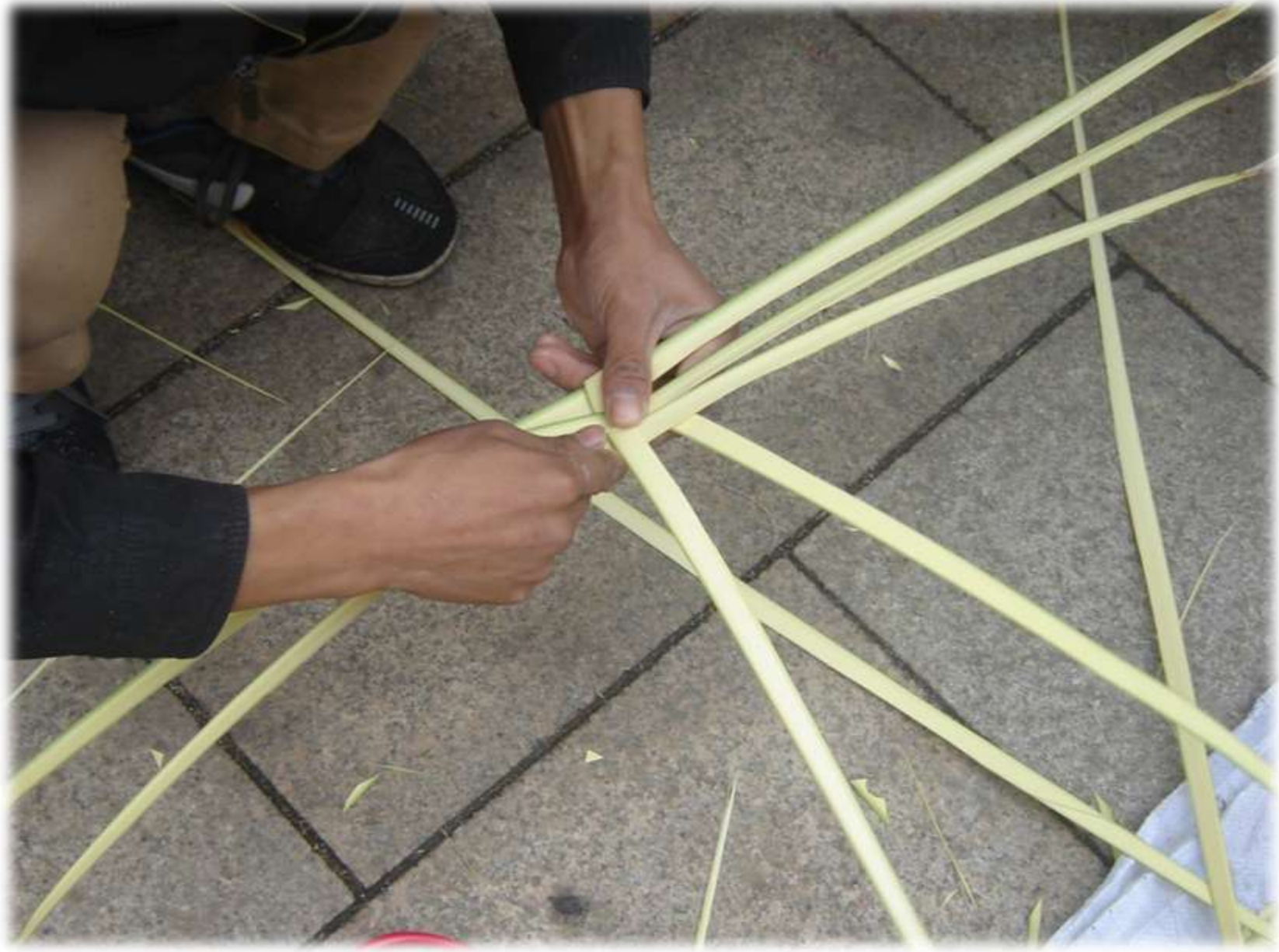

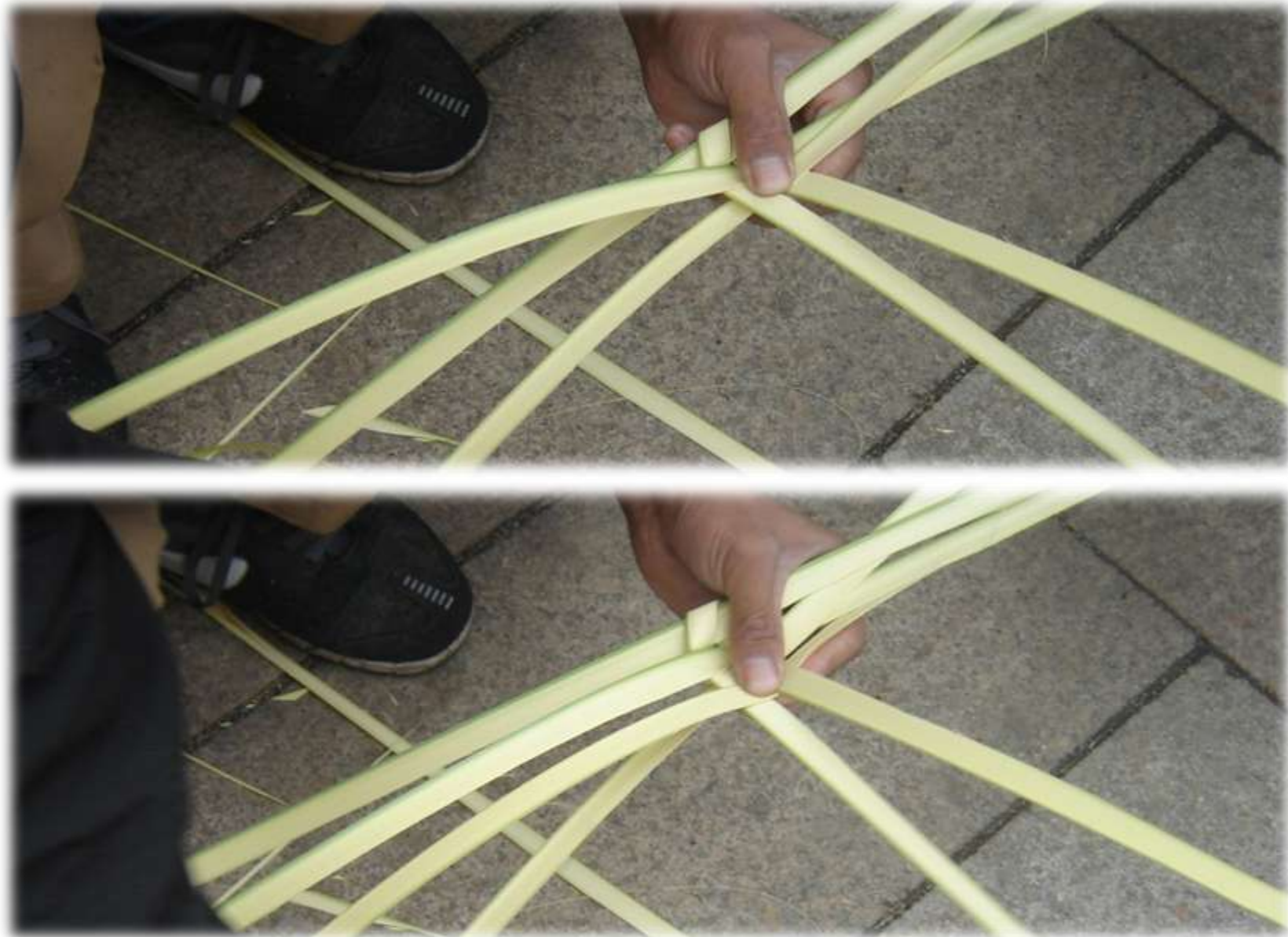



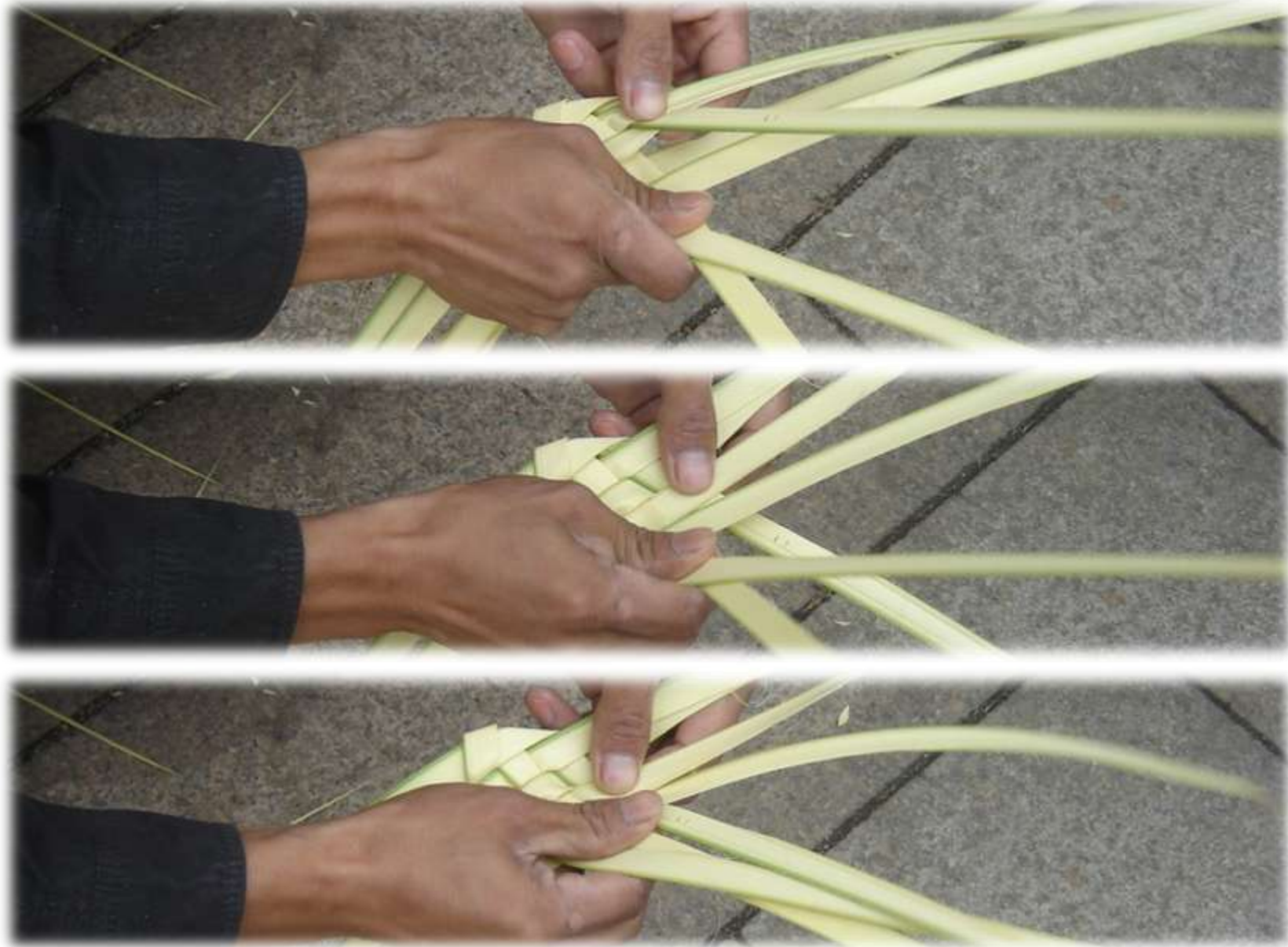



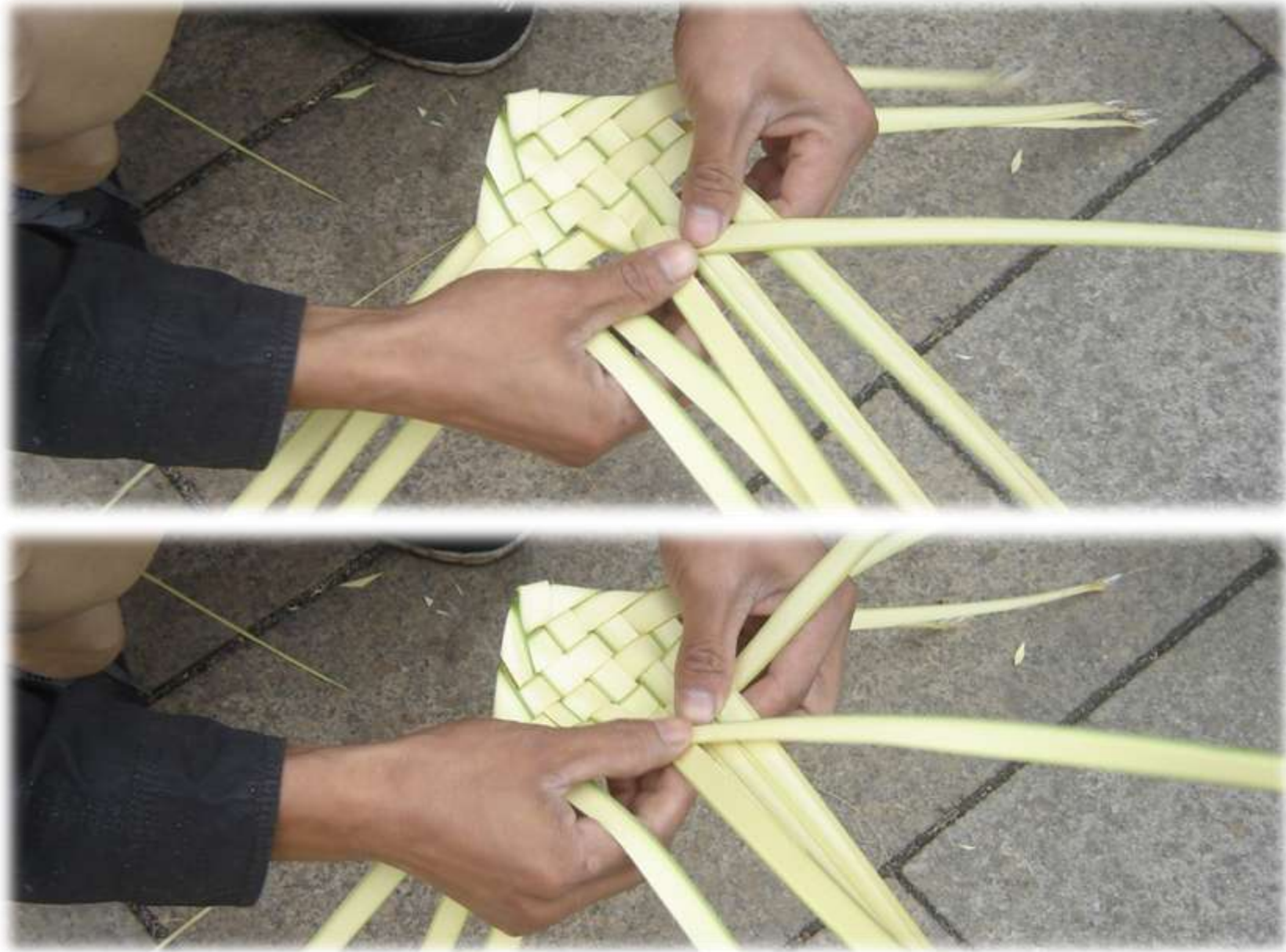

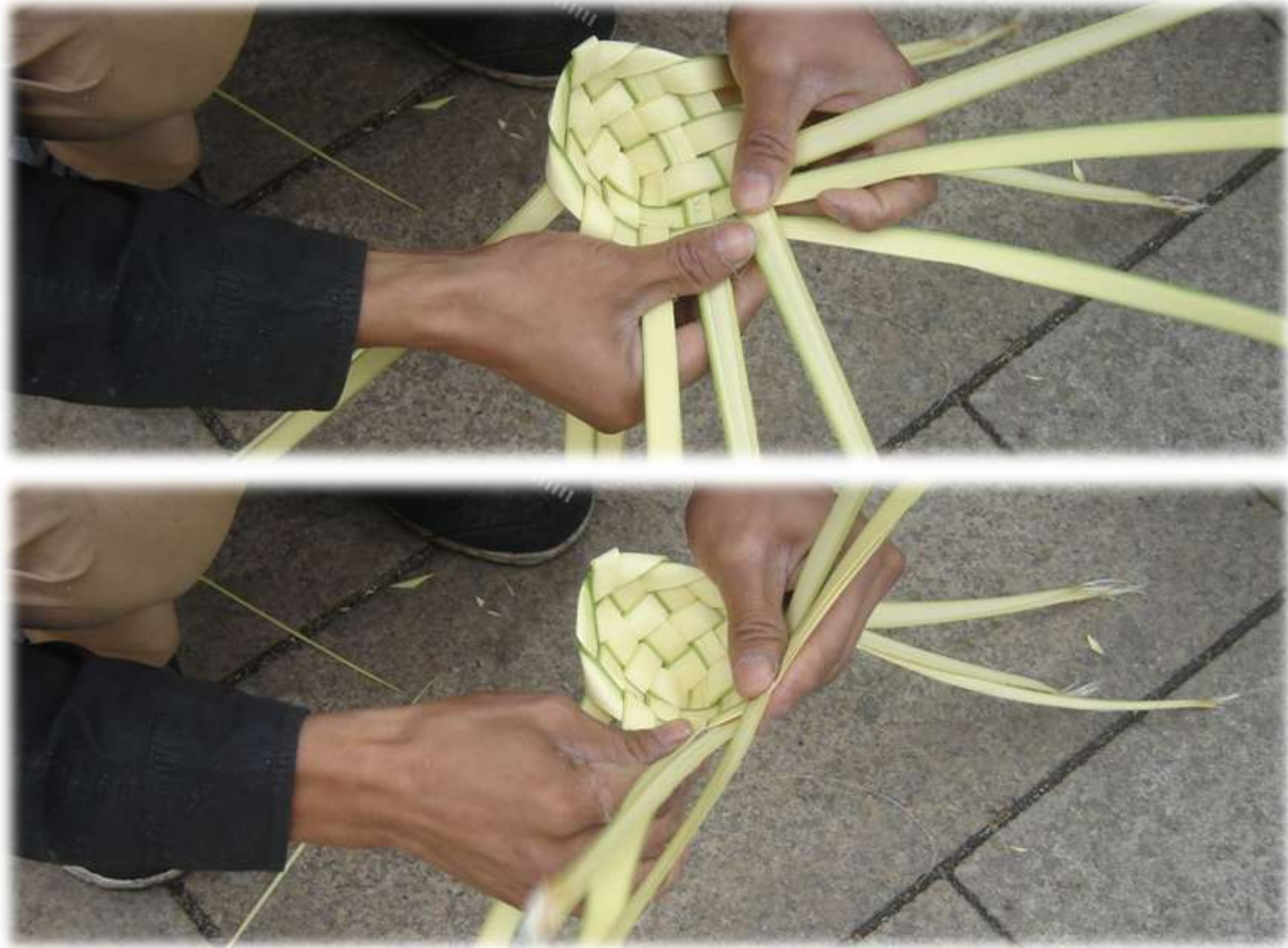

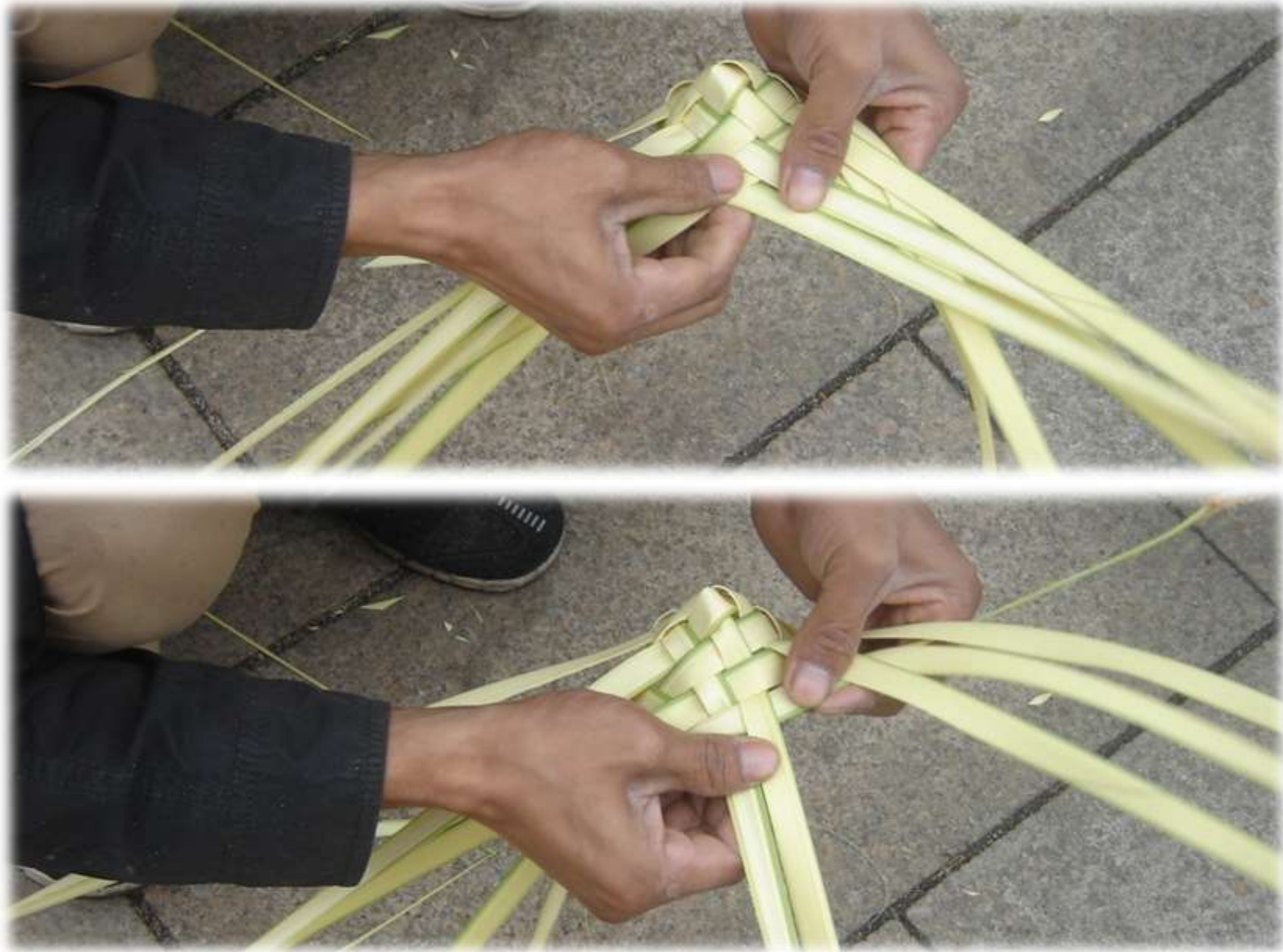





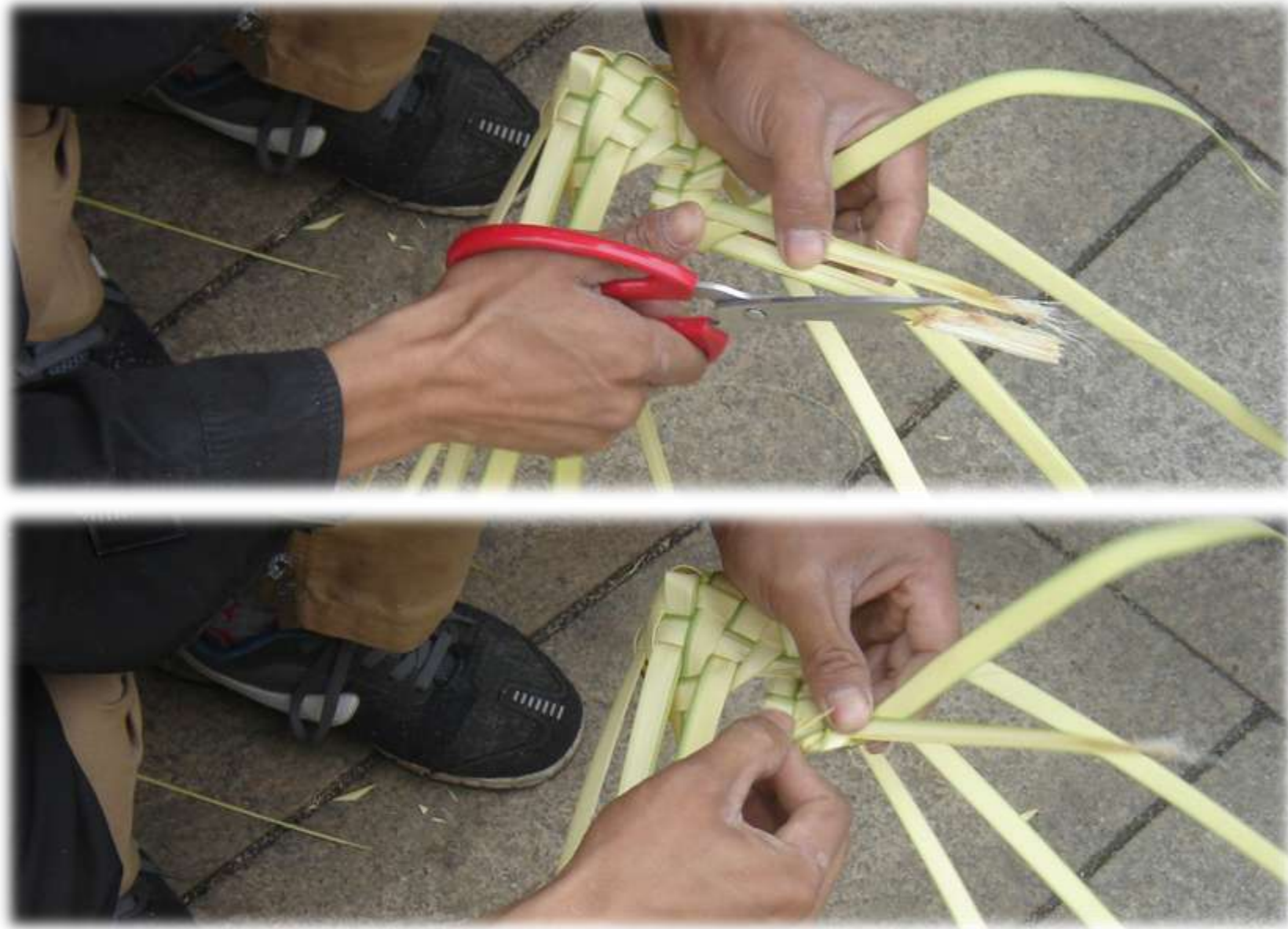

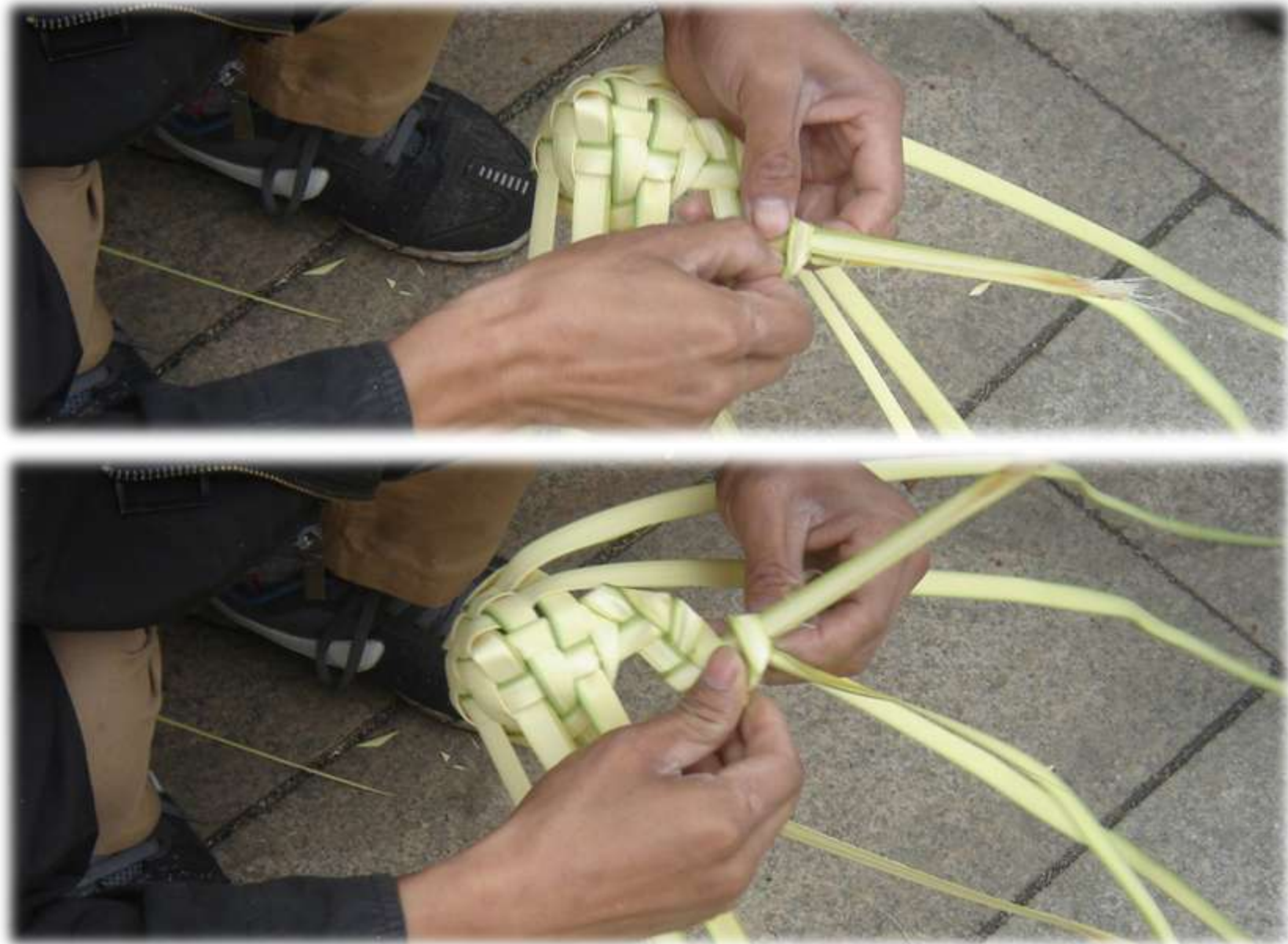

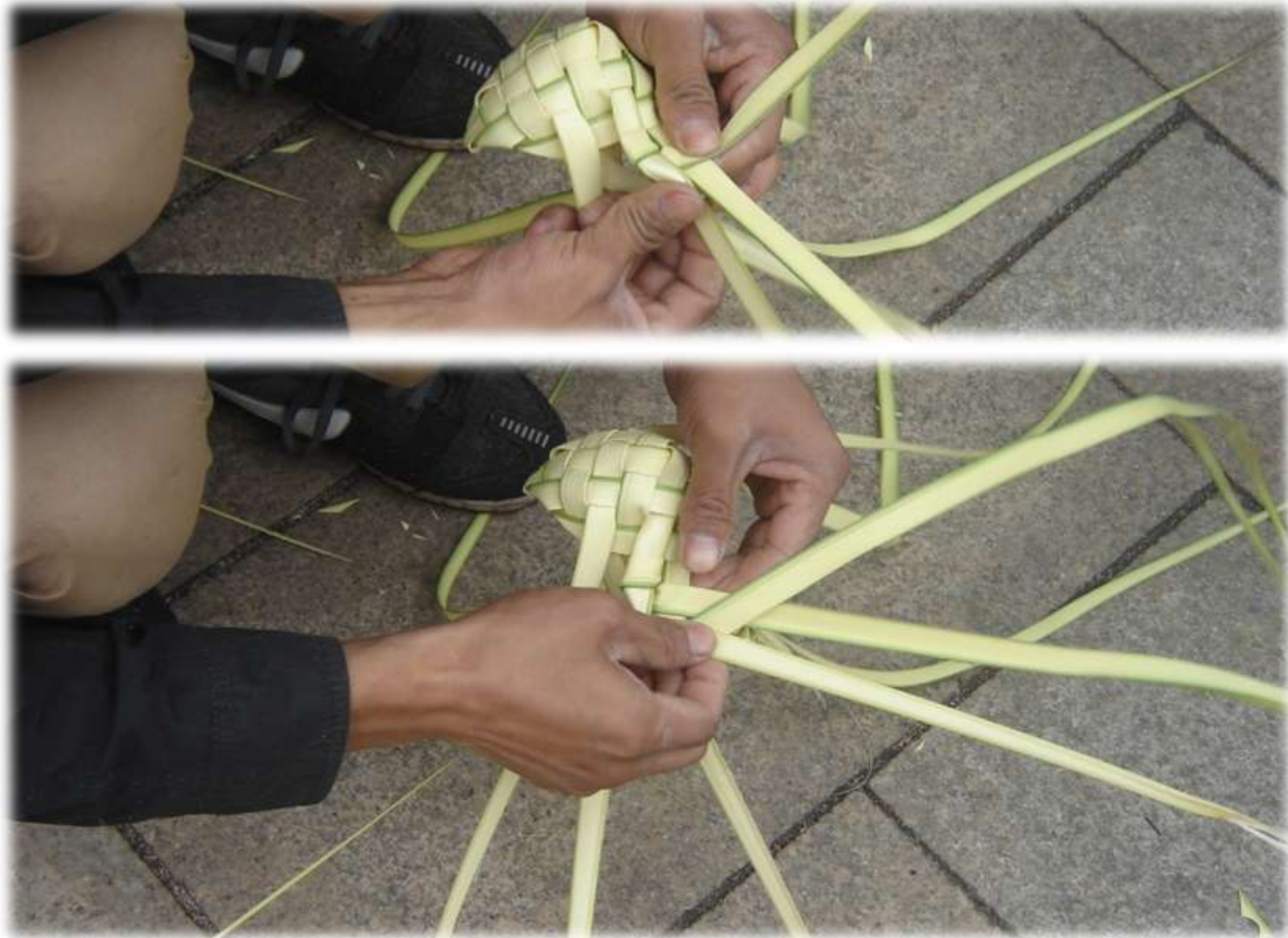

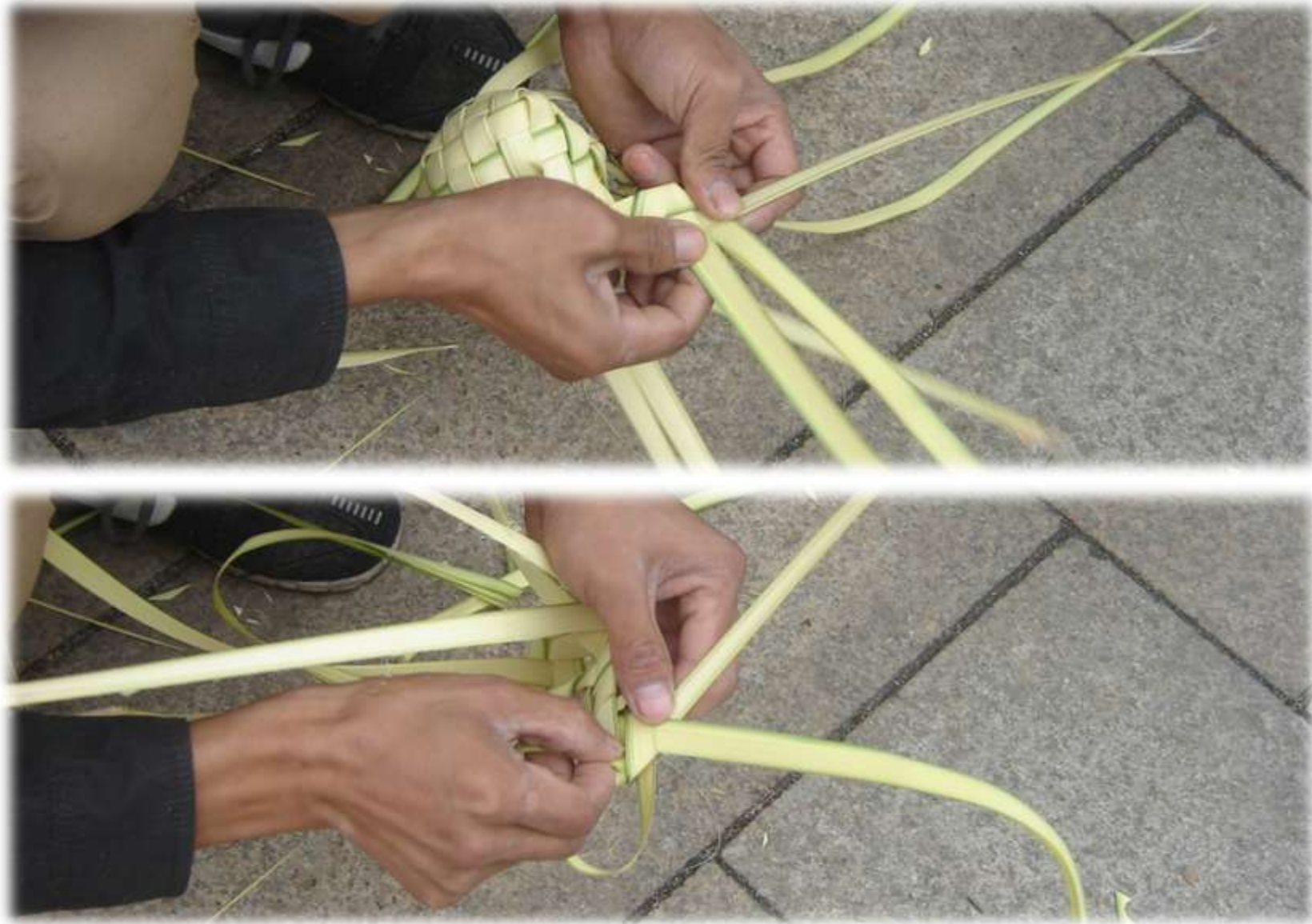

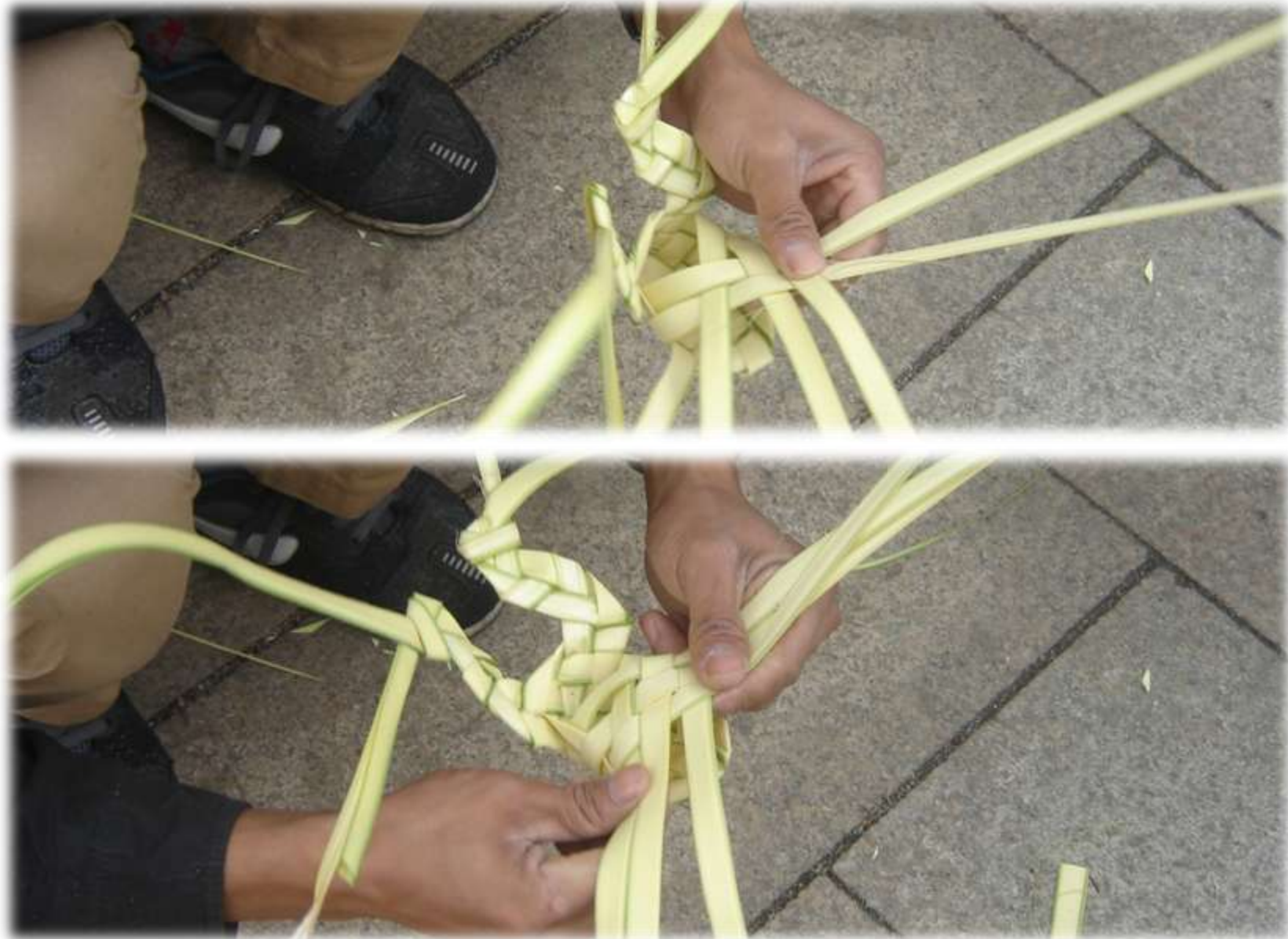

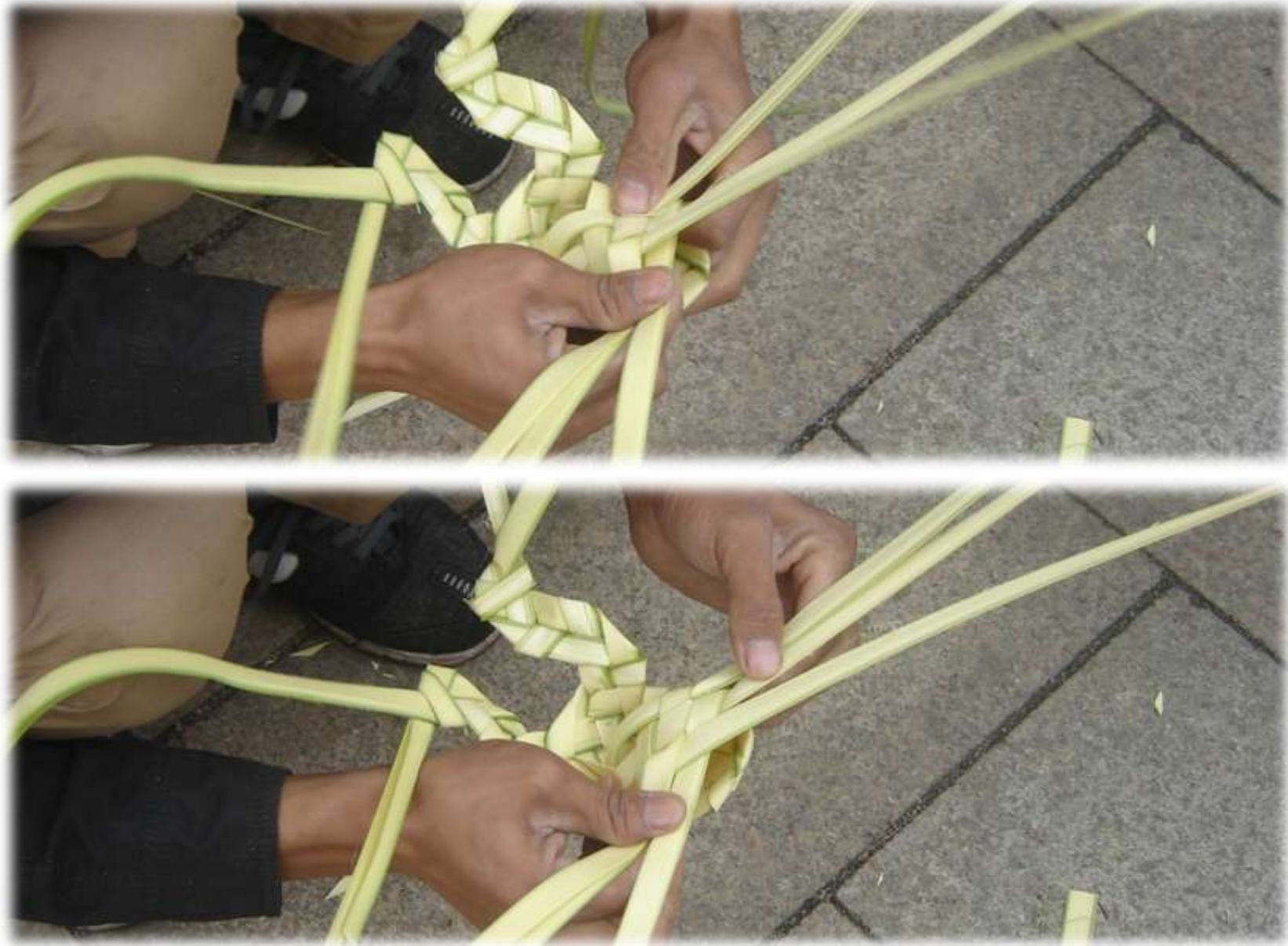

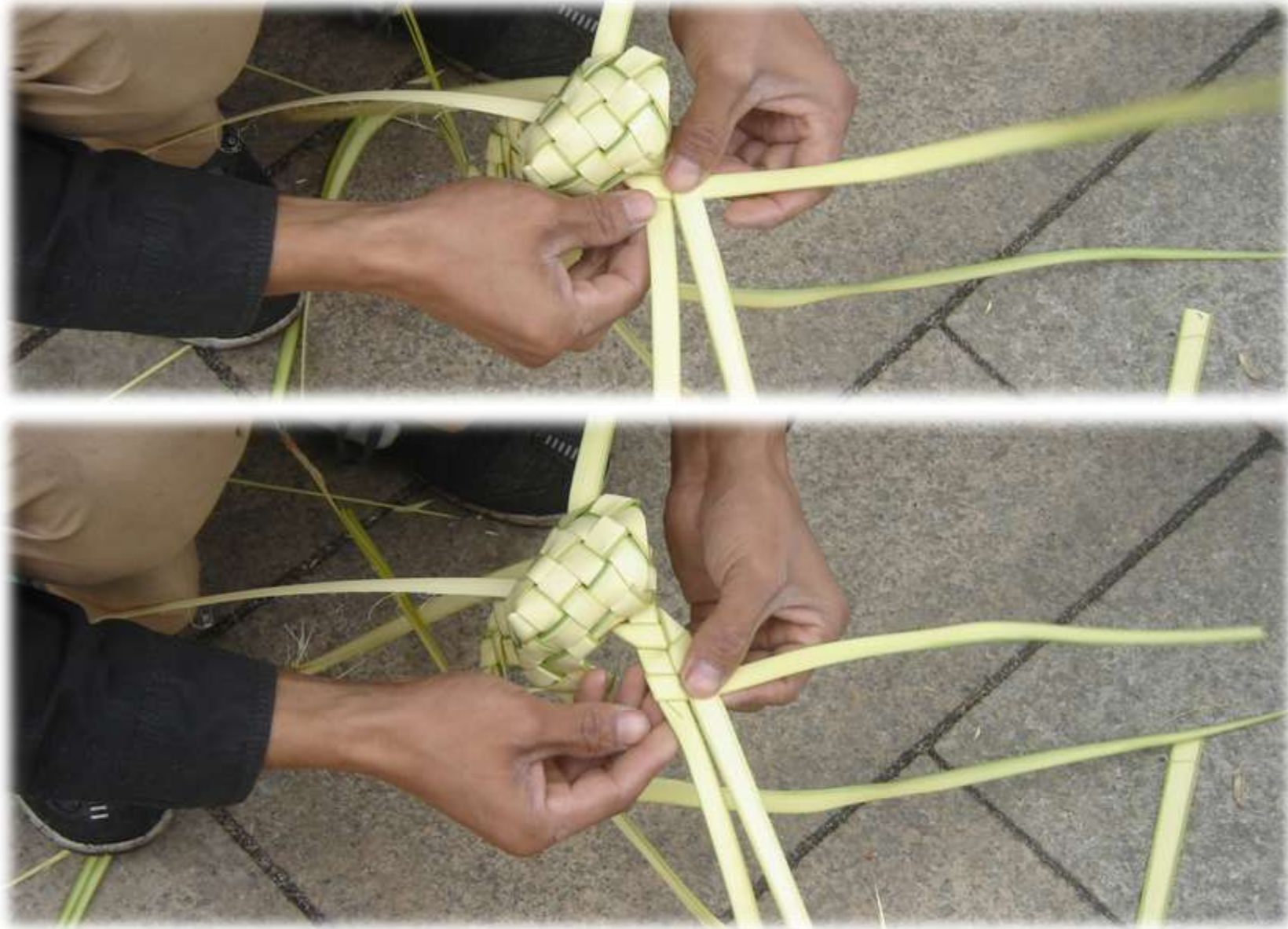









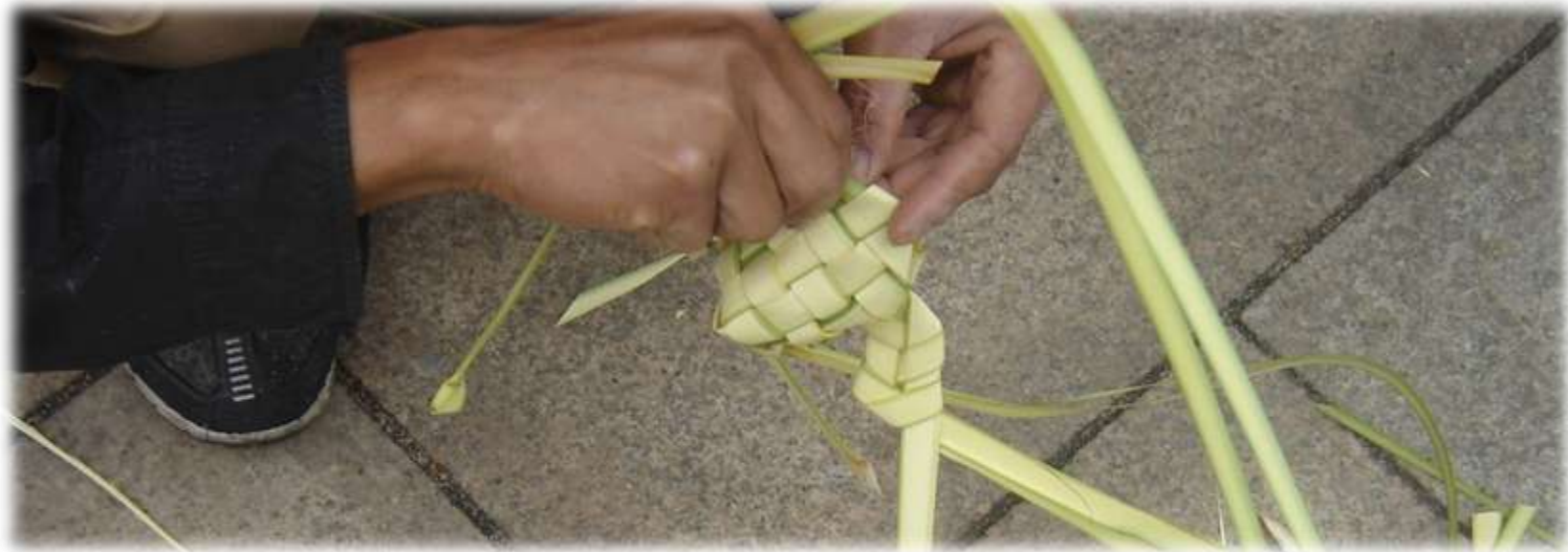

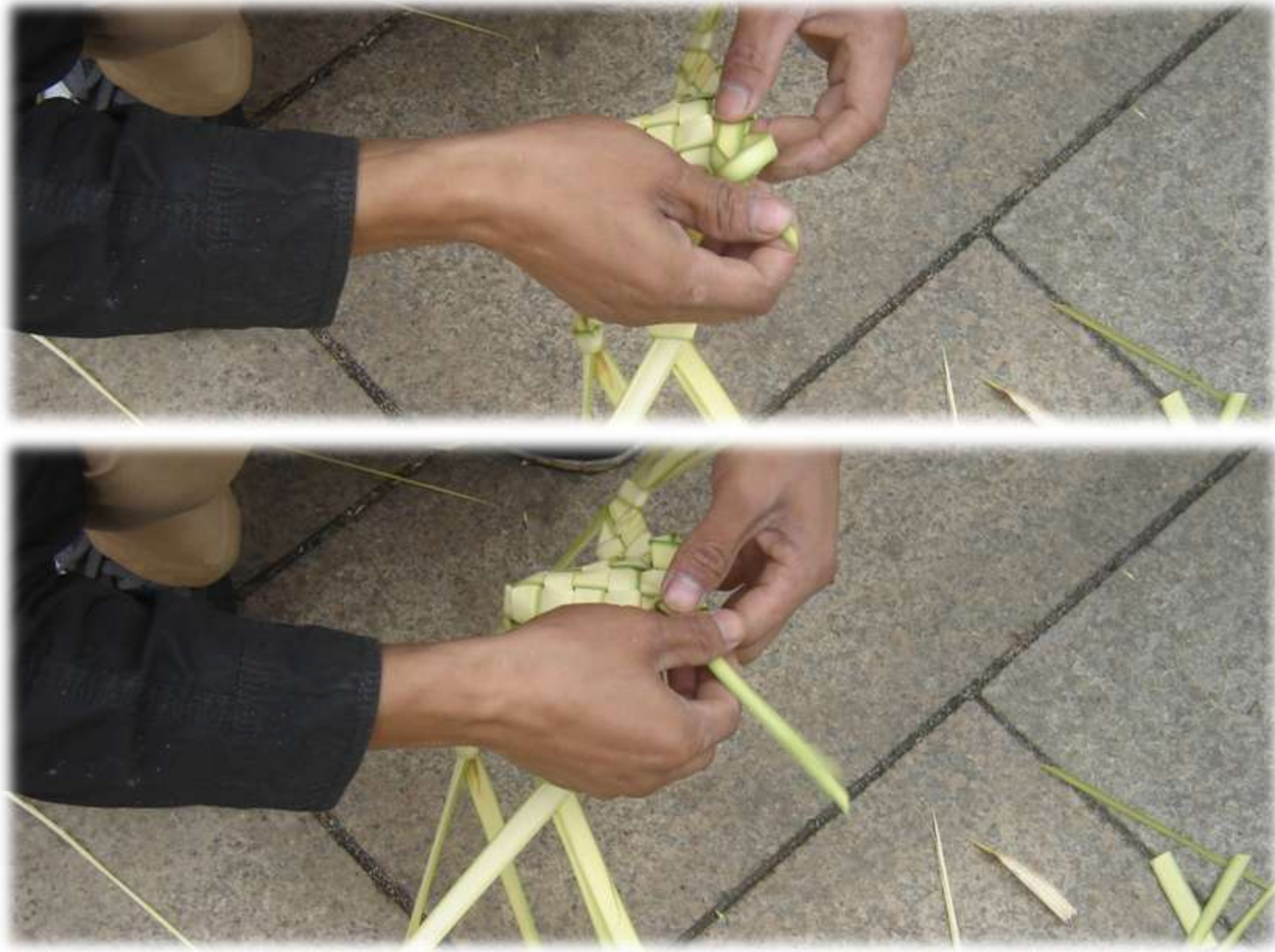

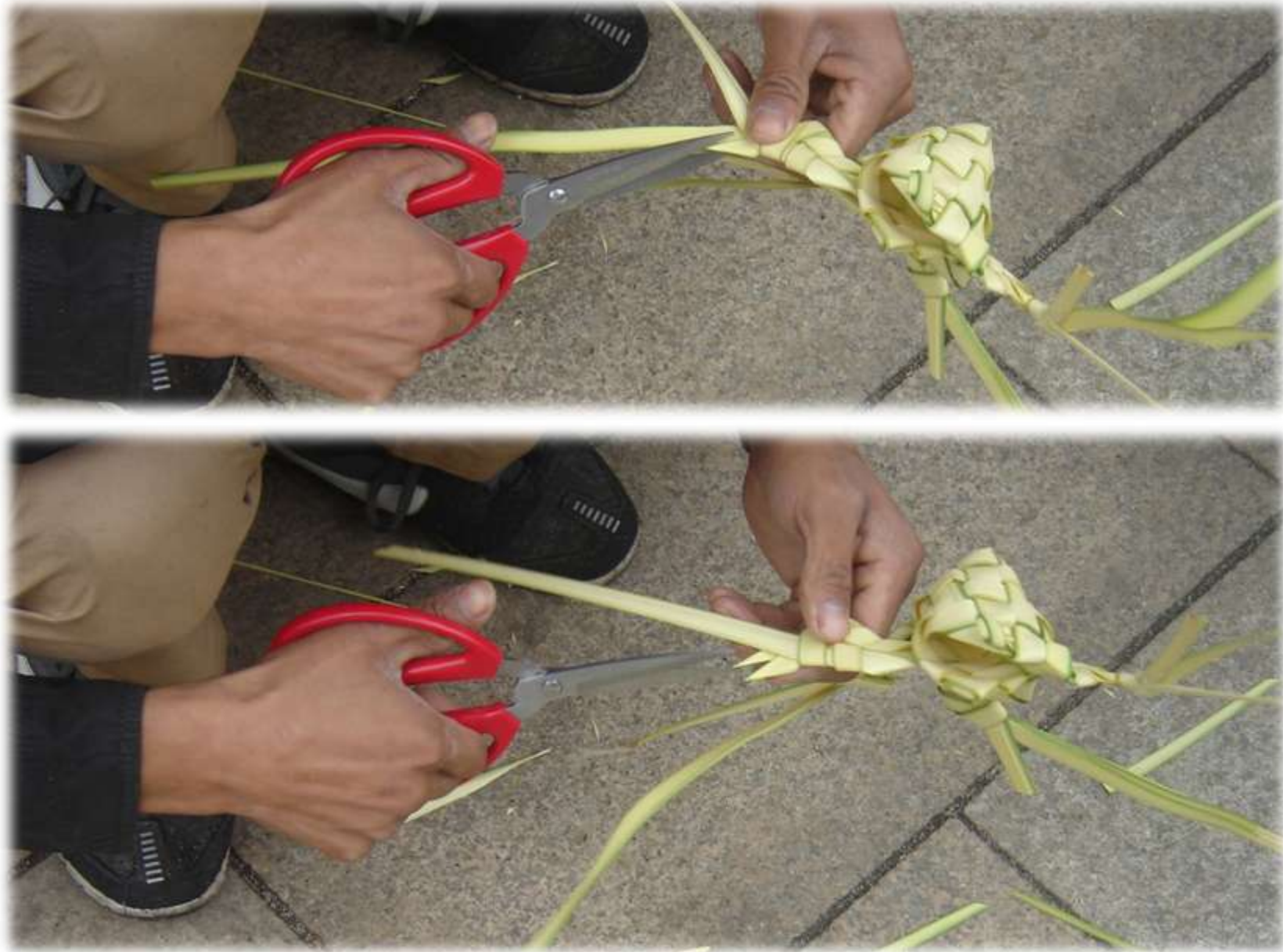

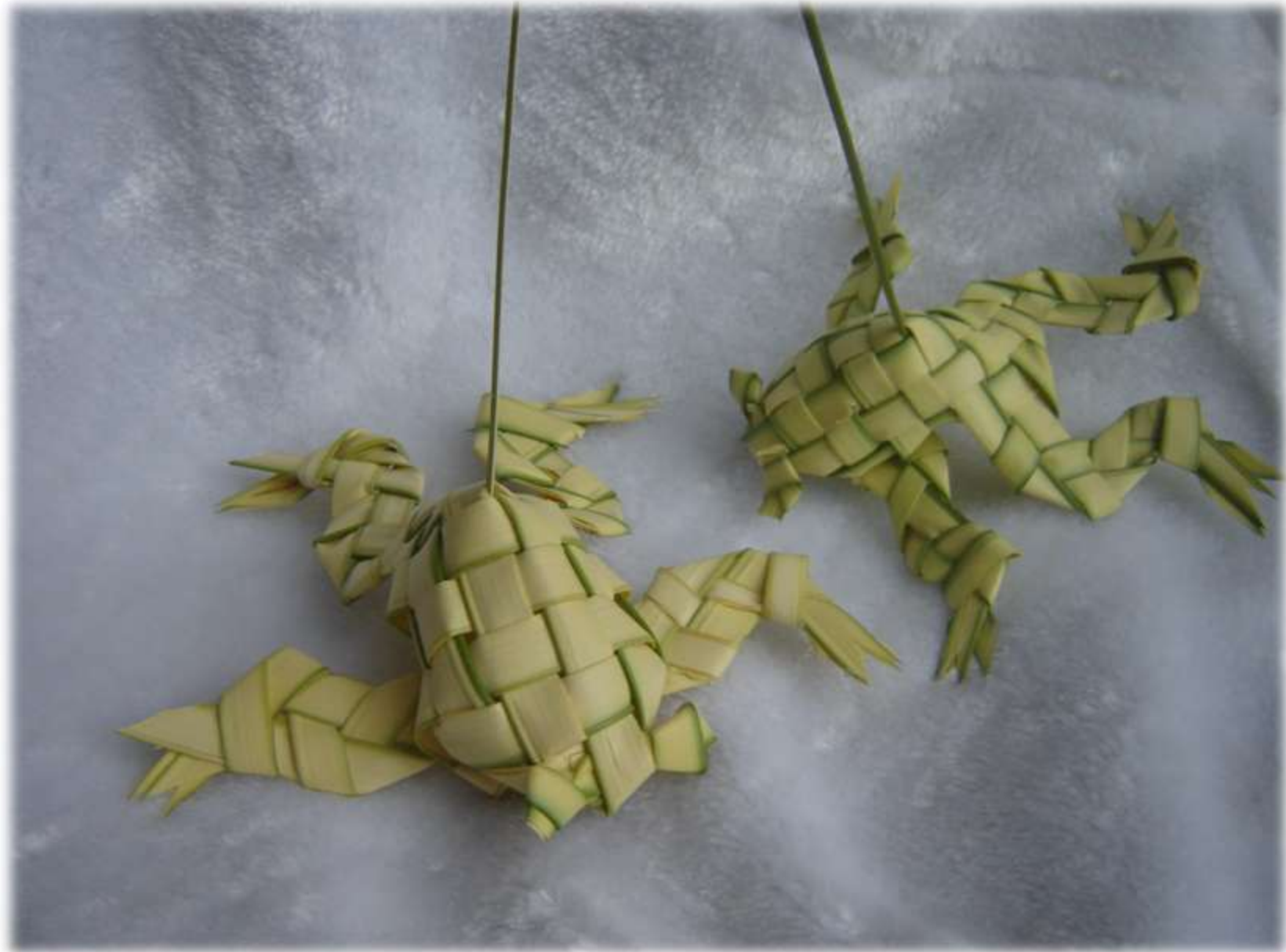

1



2



3

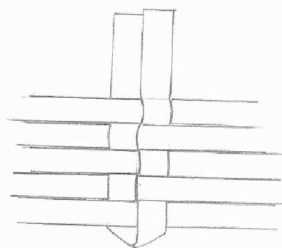

4

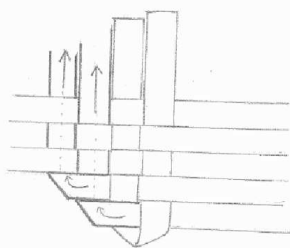

5

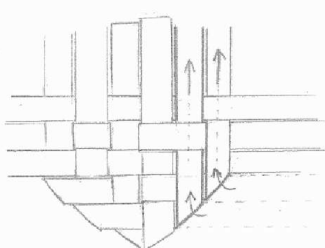

6

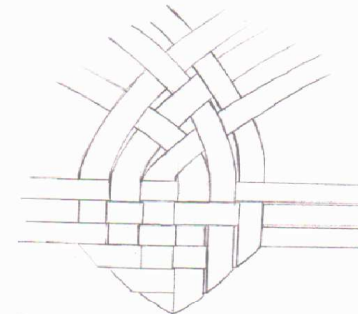

Tightly weave as the picture shown above and pull it together

7

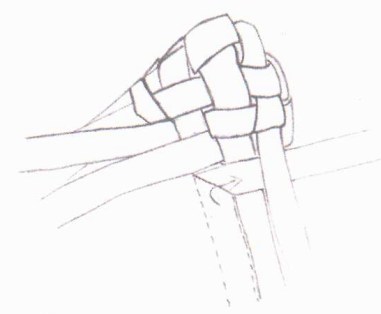

Tightening of the weave will create this shape

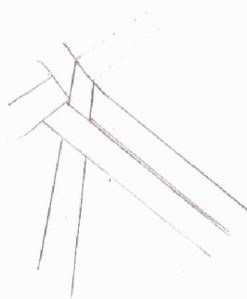

8 To make it's right leg

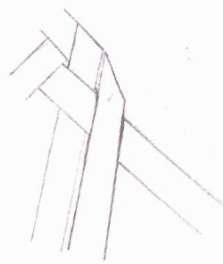

9

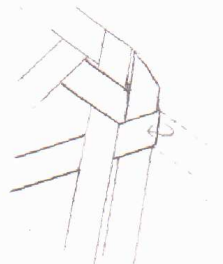

10

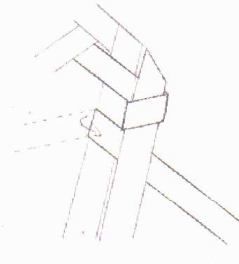

11

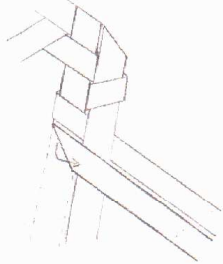

12

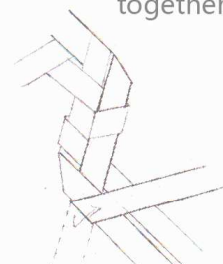

13

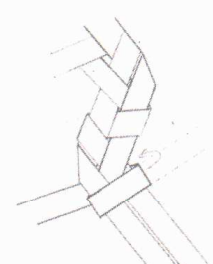

14

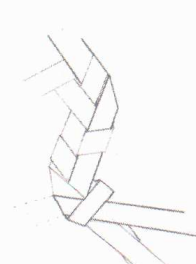

15

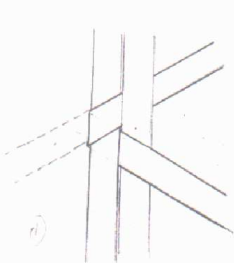

17 To make it's left leg

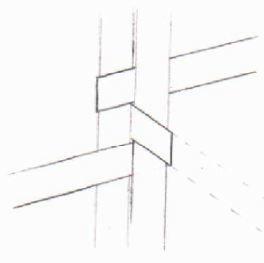

18

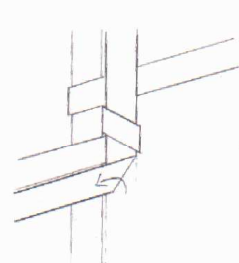

19

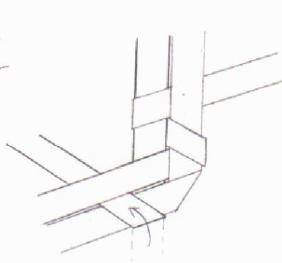

20

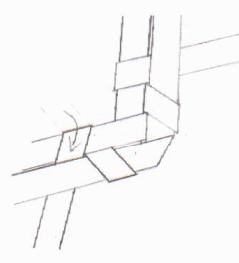

21

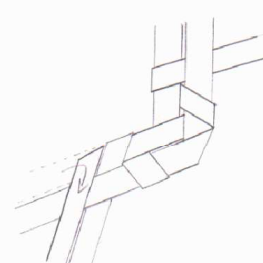

22

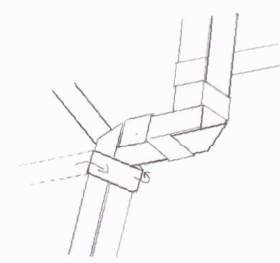

23

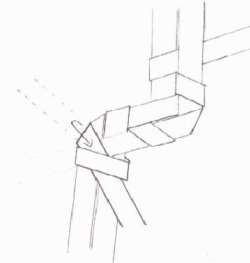

24

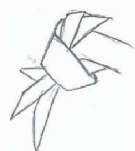

25 Cut it into the shape shown above

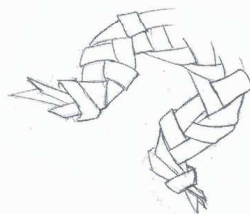

26

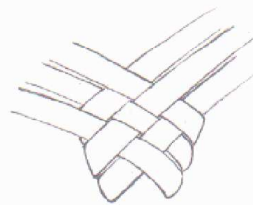

27 Flip it and make it's belly

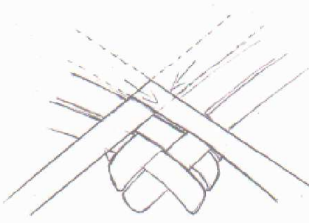

28

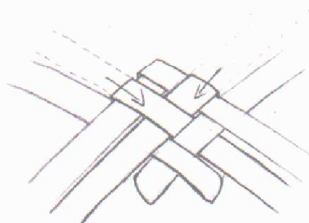

29 Make the right and left leg in the same manner shown above

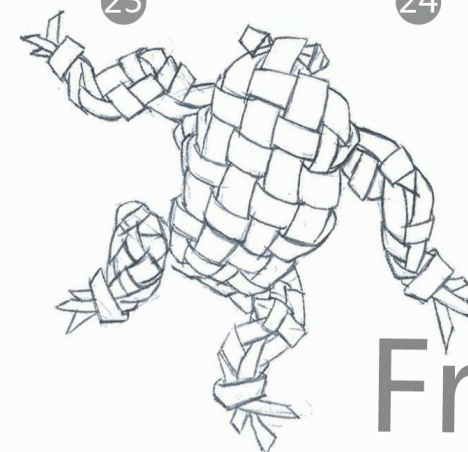

Frog



Weaving-Bird

Material

The leaves of palm trees(Fresh and tender)
Scissors

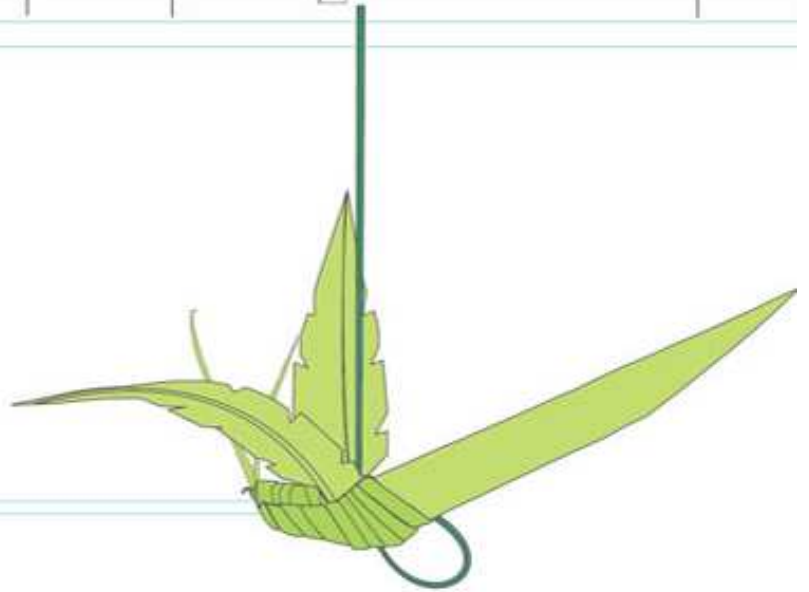
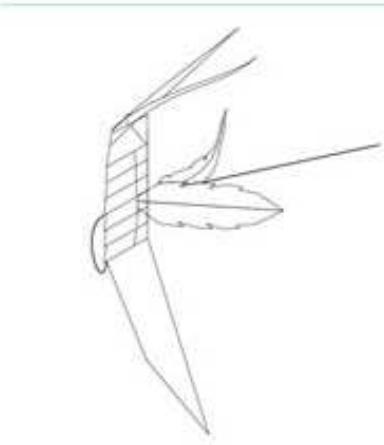
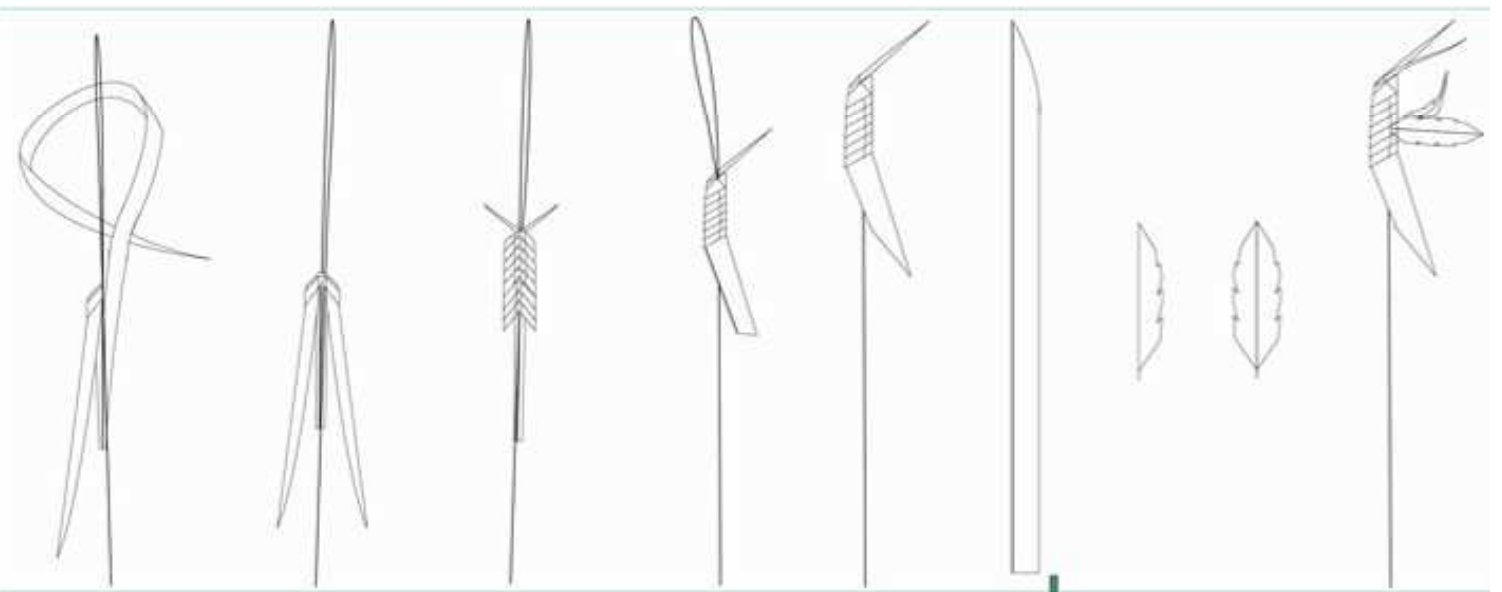
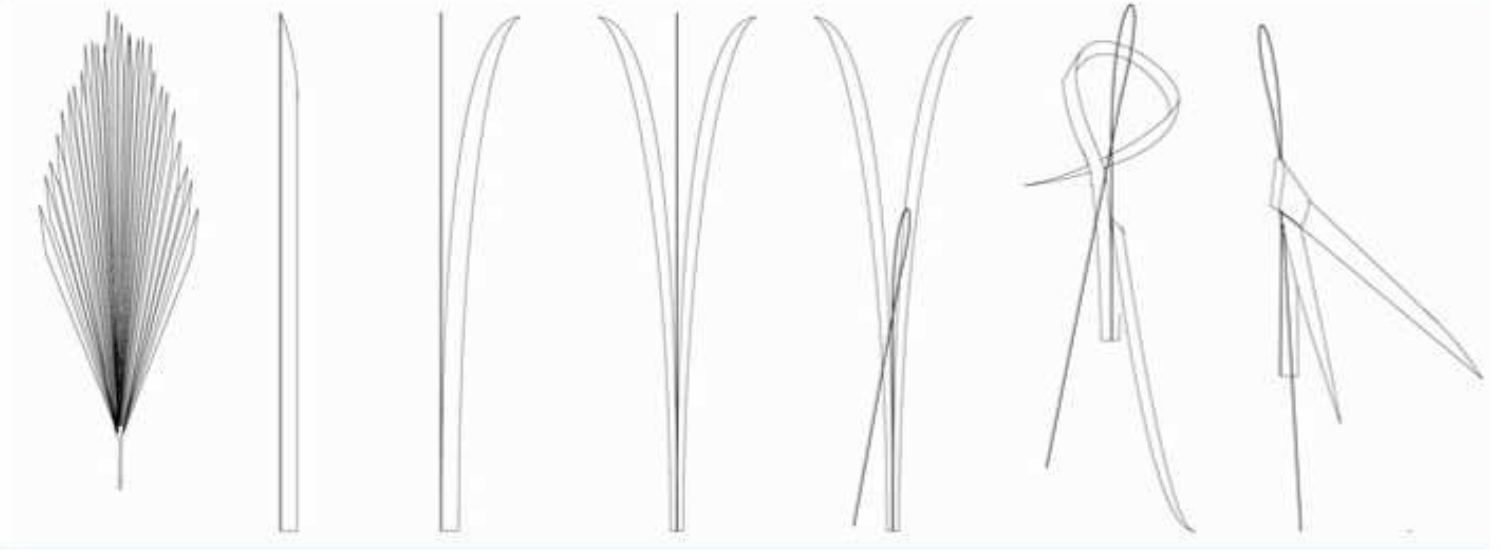

LET'S MAKE THE BIRD



- ① Fold the palm leaf in half.
- ② Cut the stem to the half of the leaf.
- ③ Fold the stem and make a circle.
- ④ Take the above leaf round the stem, and tense the leaf.
- ⑤ Pick the below leaf.
- ⑥ Do the same as the above leaf.
- ⑦ After getting this, fold the leaf.
- ⑧ Fold it again.
- ⑨ Do the step 3-8 about nine times.
- ⑩ Cut end of strips which is narrow in the rolled part of midrib to present the head.
- ⑪ Make hole on body by sharpness of scissors to put the wings.
- ⑫ Finish the bird.

Material: palm leaf
Scissors

Make the wings

1. Took part of the palm leaf and fold it.
2. Cut the leaf as the wing's shape.
3. Unfold it and get two wings.

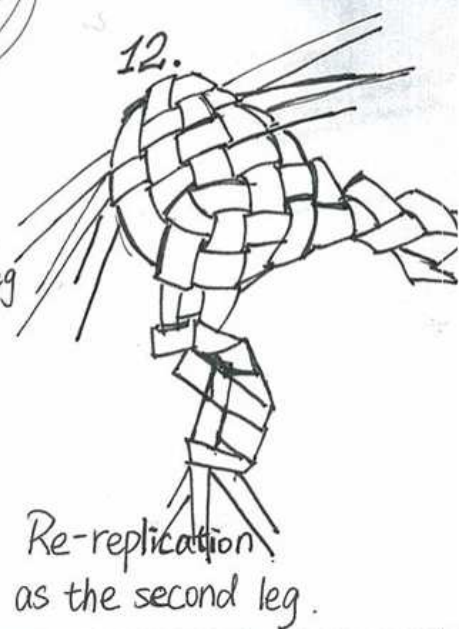
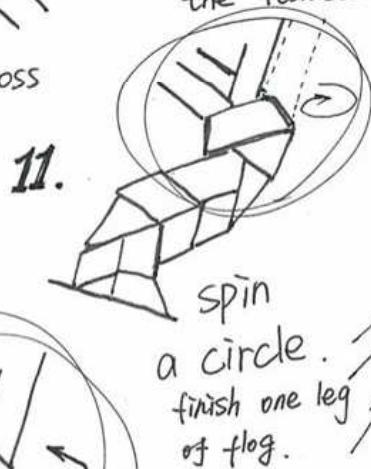
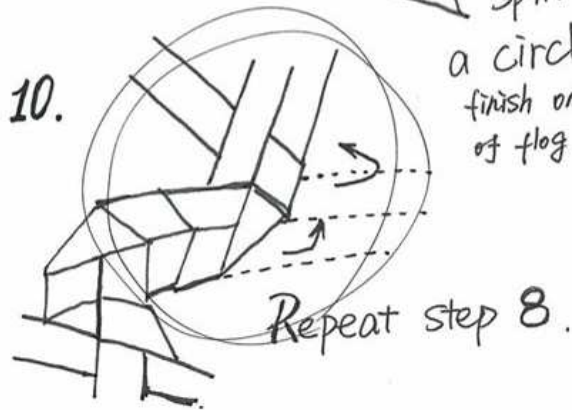
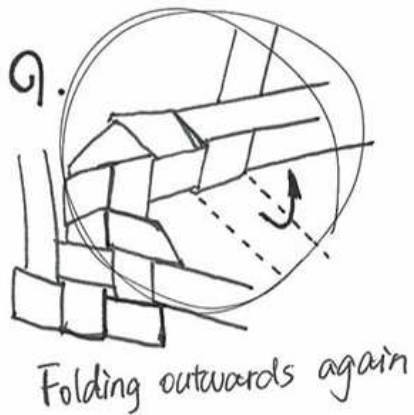
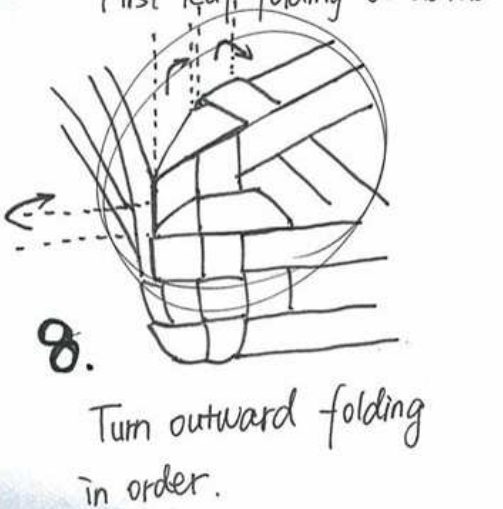
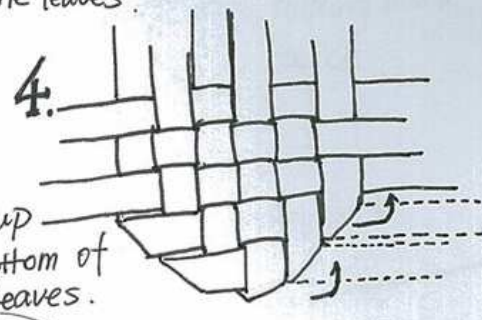
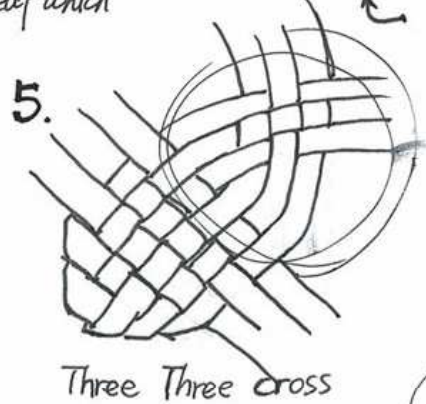
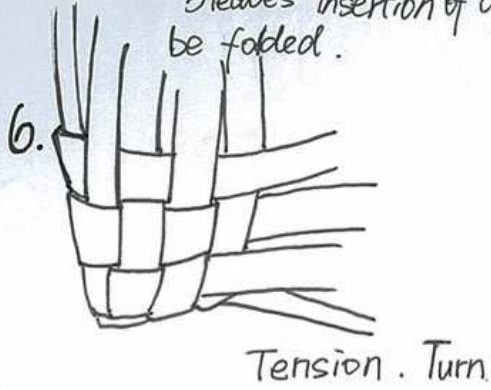
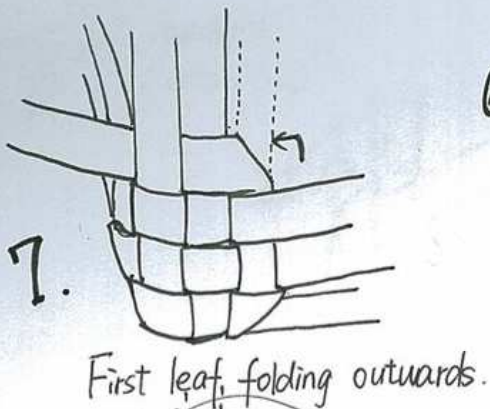
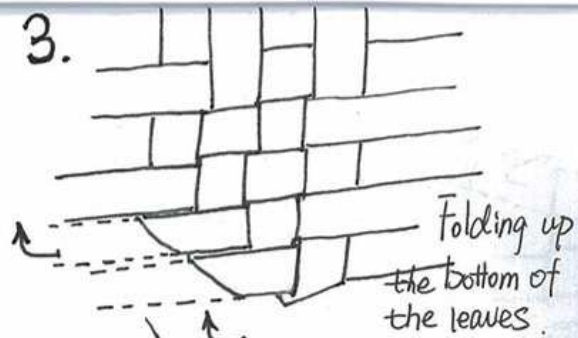
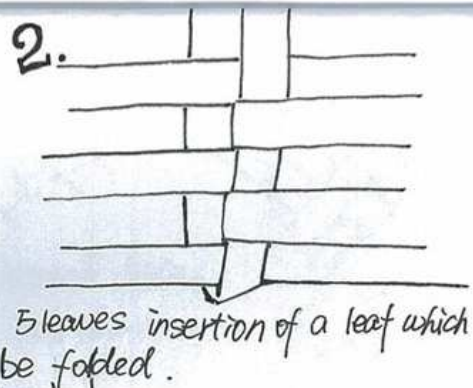
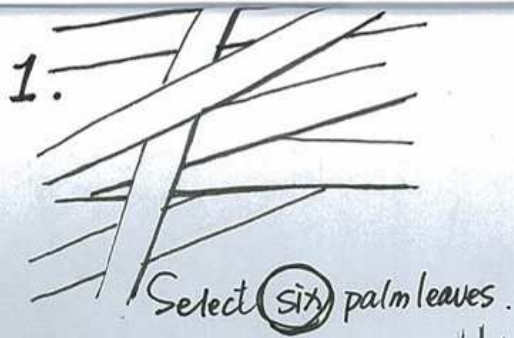

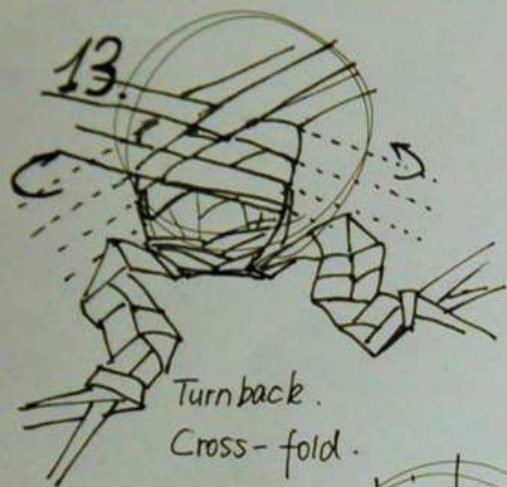

13. Turn back.
Cross-fold.

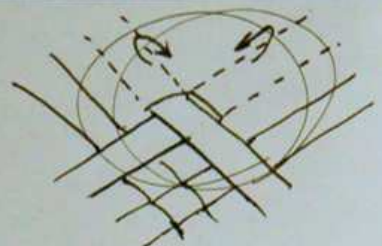

14. Outward folding
top two leaves.



15. Outward folding.
insert.

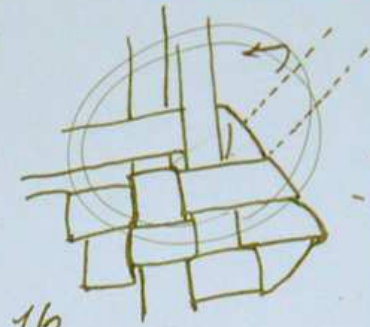

16. Lateral insertion

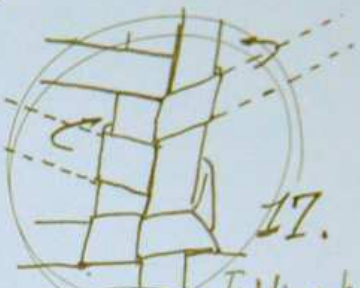

17. Folding back,
twice.

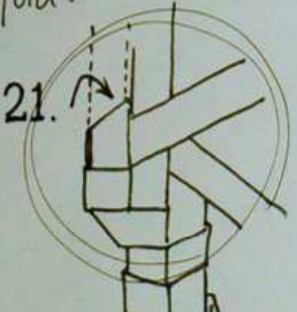

21. Folding back.

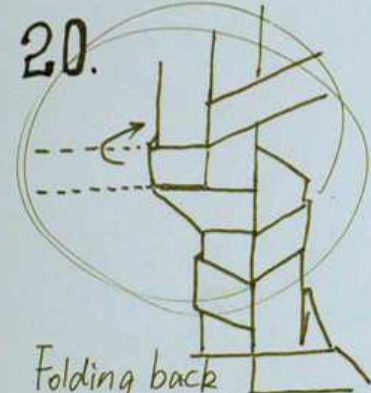

20. Folding back.

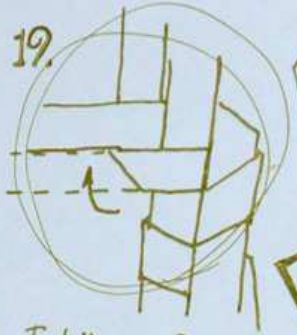

19. Folding up.

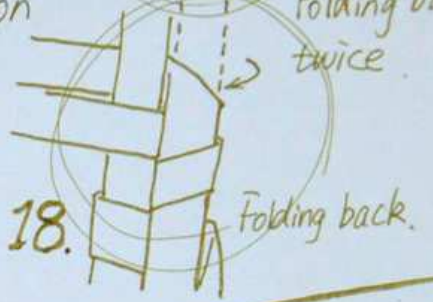

18. Folding back.

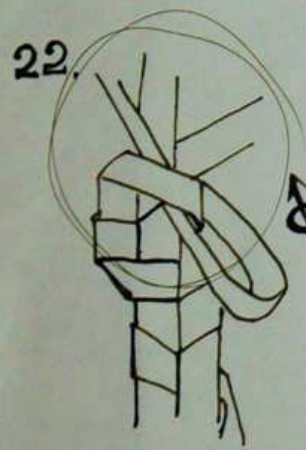

22. Criterium.
Truss.

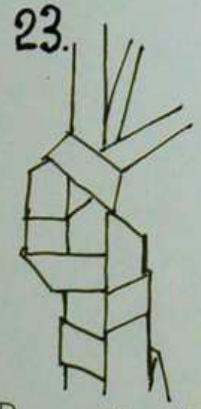

23. Repeat the other foot.

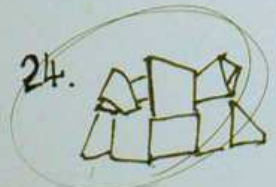

24. With a rope
through the top.
Knotted at both
ends of the leaves.

25. Cut off the
excess palm leaves.
Finish.

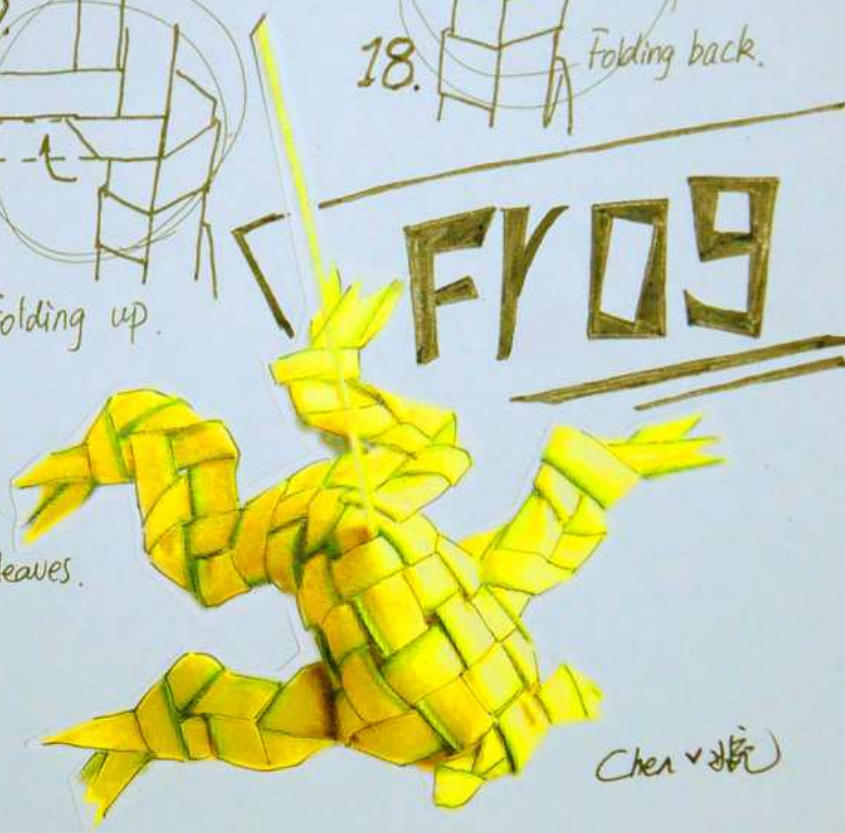



1 Cut the leaf of palm

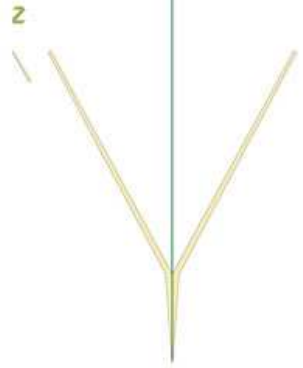

2 Tear it apart and cut its top

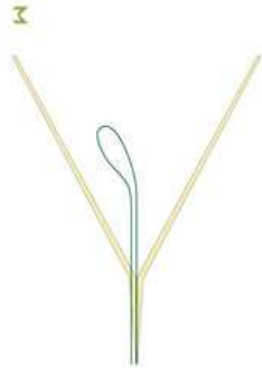

3 Bend the stem

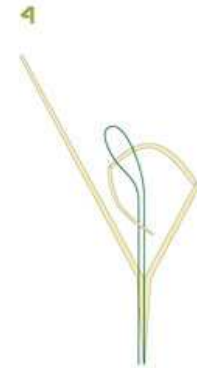

4 Bend the leaf around the stem



5 Flat the joint



6 Bend the other leaf around the stem



7 Flat it again



8 Fold the leaf along the edge of the joint



9 Fold it again along its edge



10 Bend it around the stem



11 Flat it



12 Pull the new joint down



13 Start the other side



14 Fold another one along the edge of the joint



15 Fold it again along its edge



16 Bend it around the stem



17 Flat it and pull the new joint down



18 Repeat this work several times



19 Cut 2 leaves as its wings



20 Bend around the body



21 Repeat the work like step 8 to 12



22 Start another side



23 Repeat the work from step 14 to 17



24 Flat them



25 Add 2 leaves into the gap and cut the tail



26 Repeat the work like step 8 to 12



27 Repeat that work several times



28 Encircle the leaves into the stem circle



29 Tight the stem



30 Cut the leaves like the leg



31 Get it



THE GRASSHOPPER

Frog

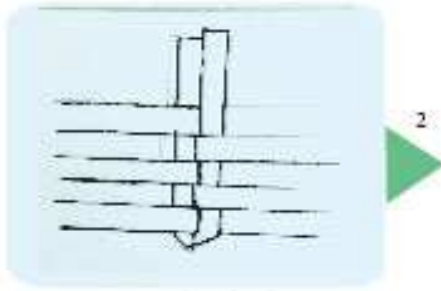

put in 5 palm leaf

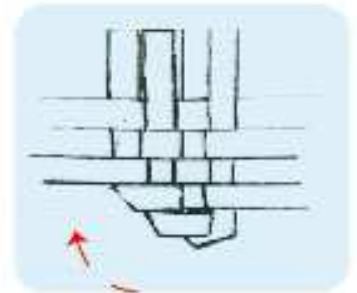

Weaving the left

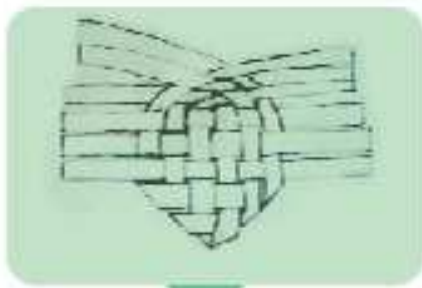

Weaving the right

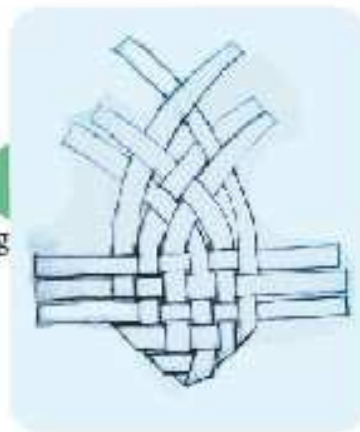

tensioning

6
Turn

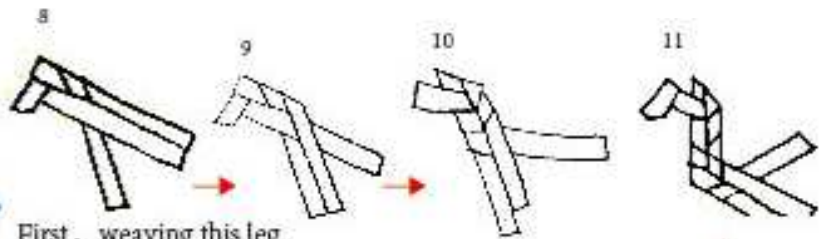
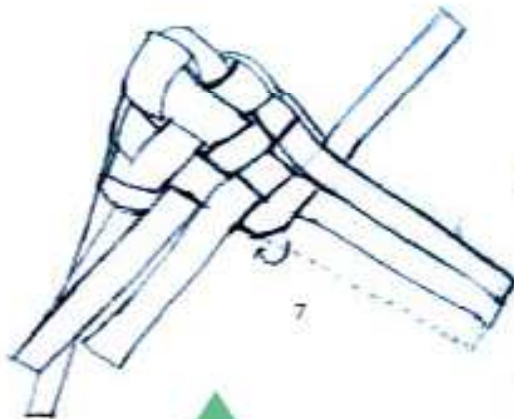

First, weaving this leg

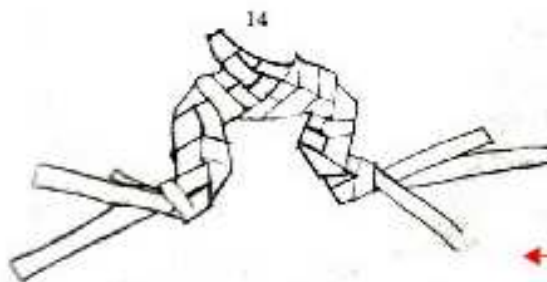
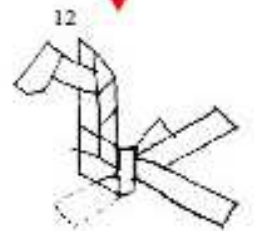

Next, get another leg use the same method



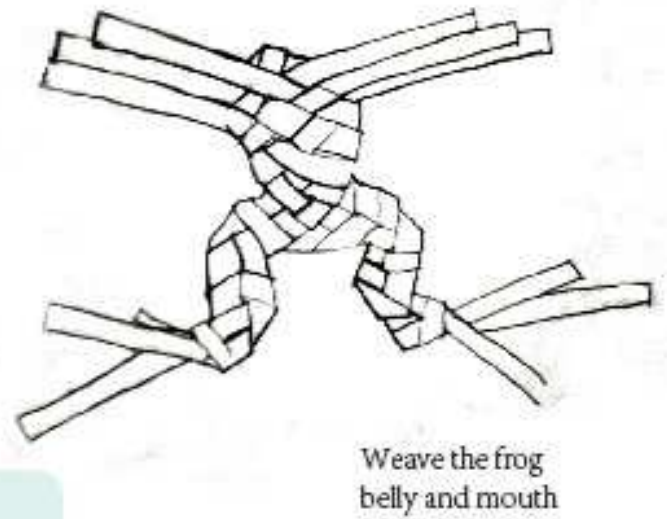
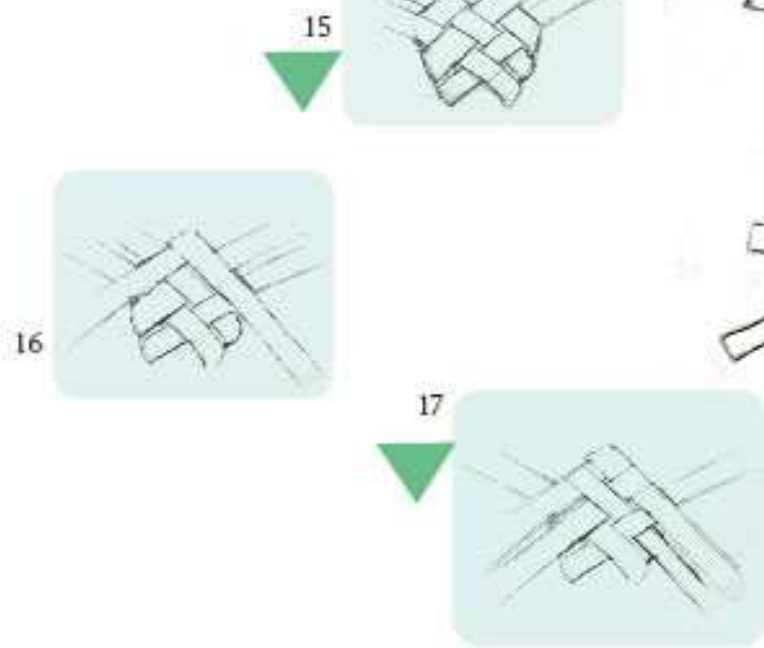

By following these steps, you can get one foreleg

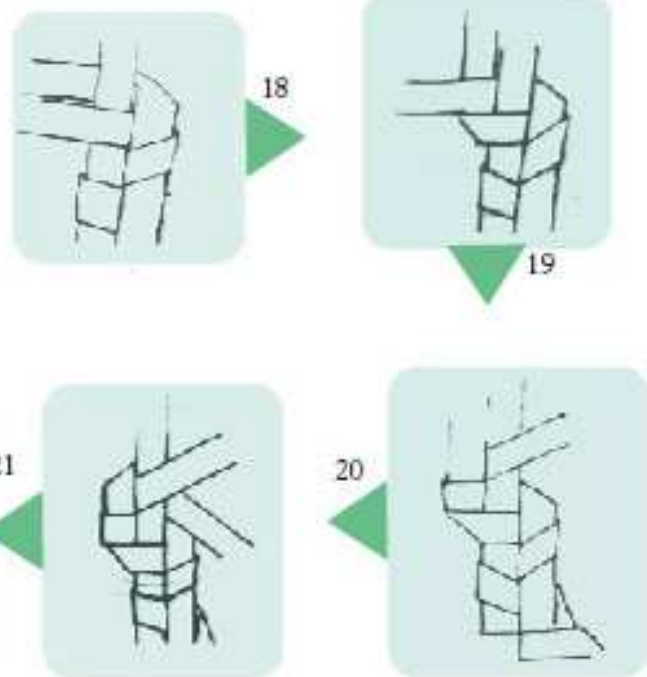

Get another foreleg
use the same method



Last, don't forget the eyes

Take out the fringe.



Folio.



Folio.



Take out



x4

Standby.

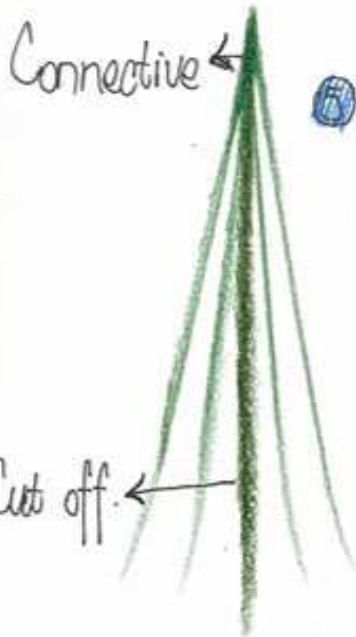

Connective

Cut off.

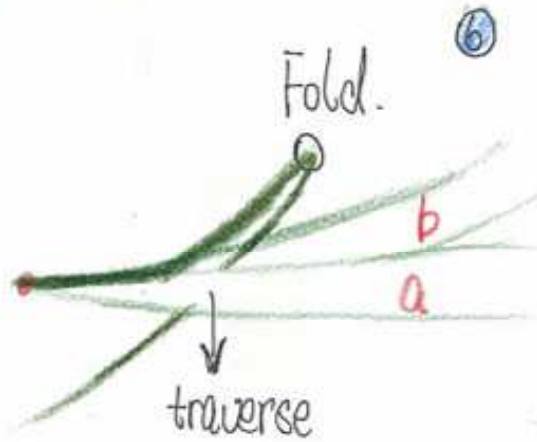

Fold.

traverse

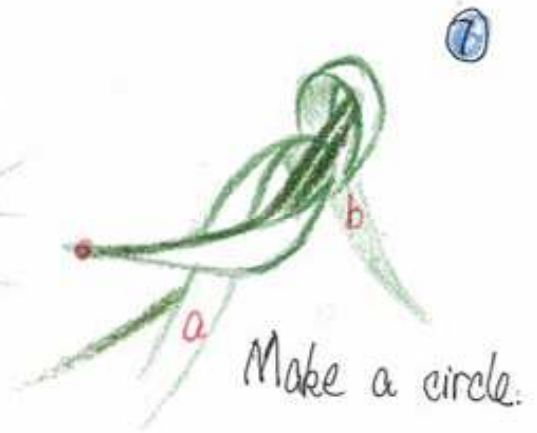

Make a circle.

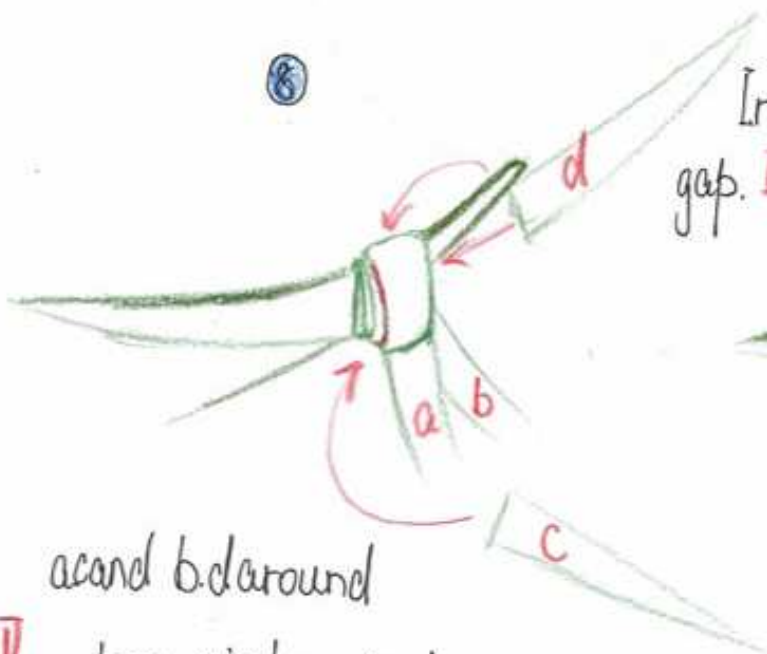

Insert the c, d in the gap. I

a and b around

II two circles in turn.

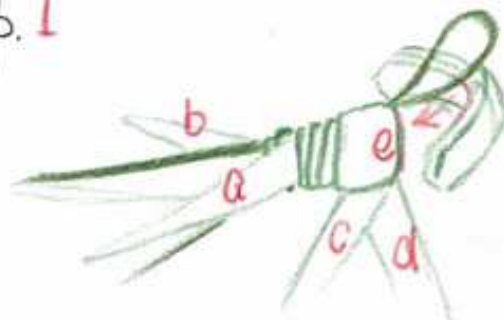

The standby fours tightly in e.



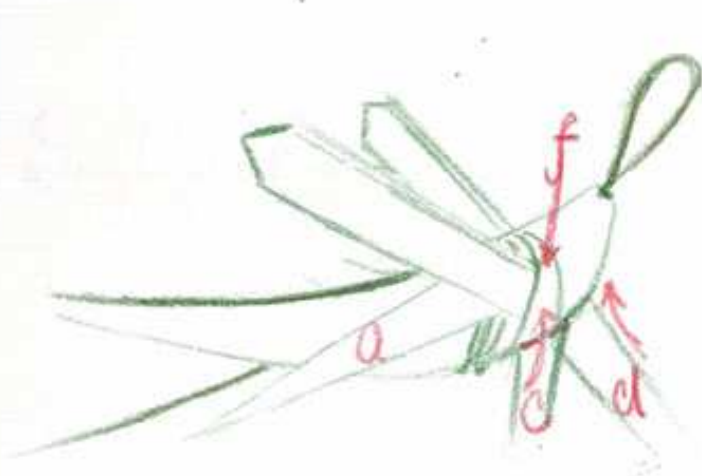

10

c. and d. around circles,
through the surface of
'f' below.

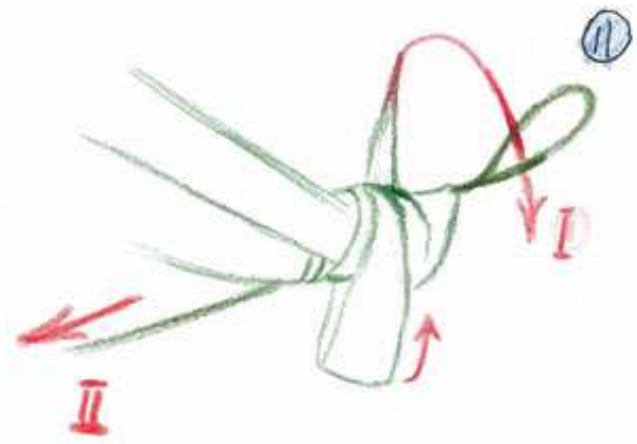

11

Through the circle.

Backward
tension.

Take out.
make it vivid.

12
Connect with lines.

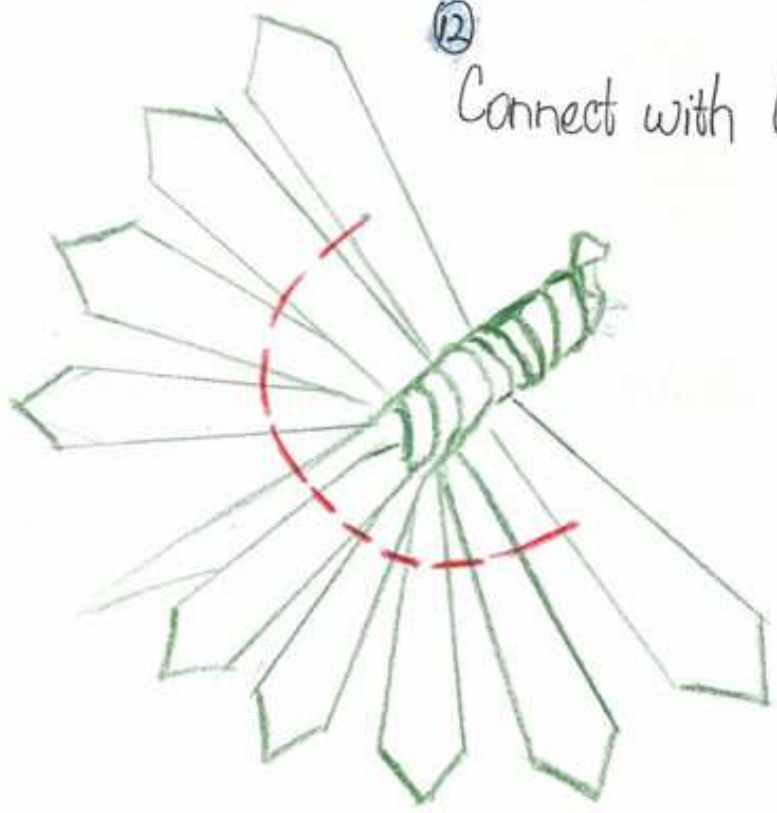

Done!

— Take out.
- - - Folio.



frog

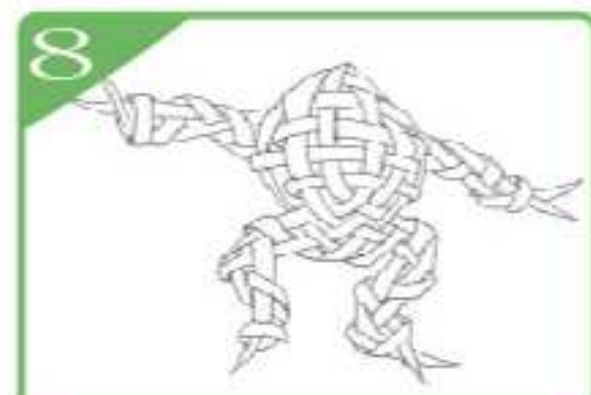
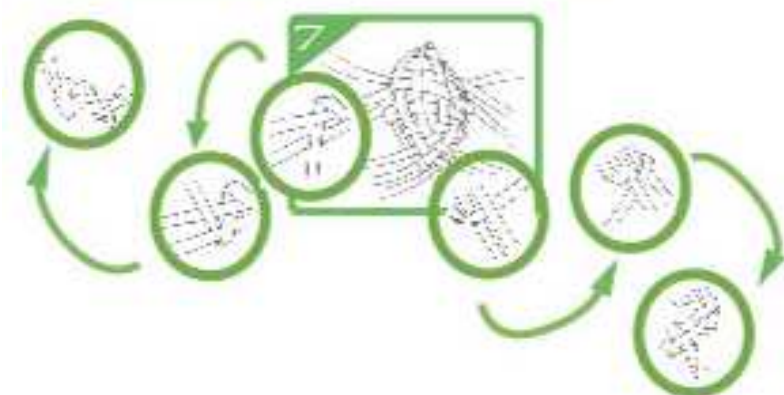
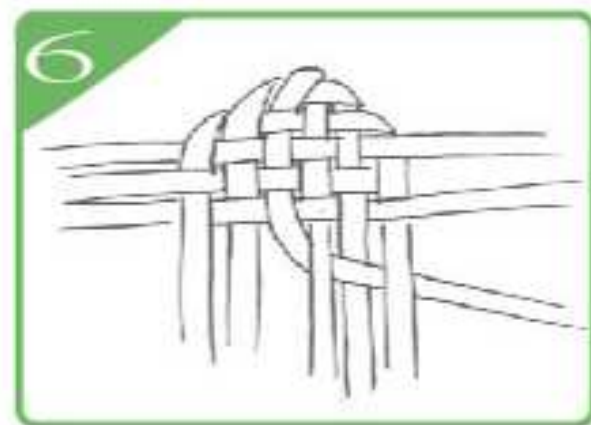
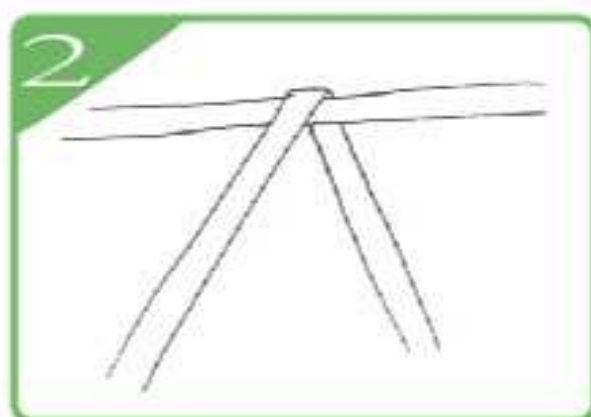

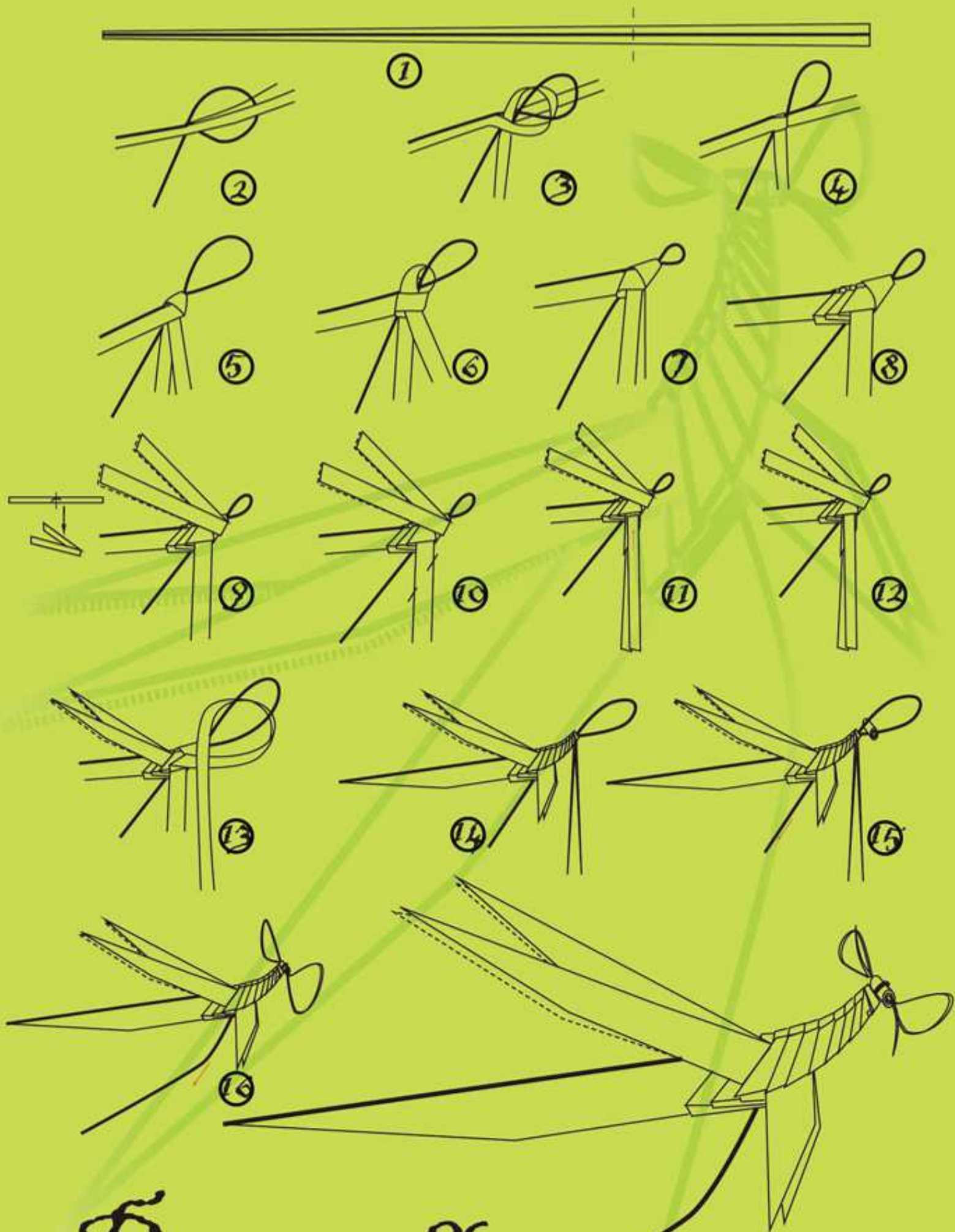

Dragonfly

201205050211李书全

Ann

李雨佳

Li YuJia

Pallasson

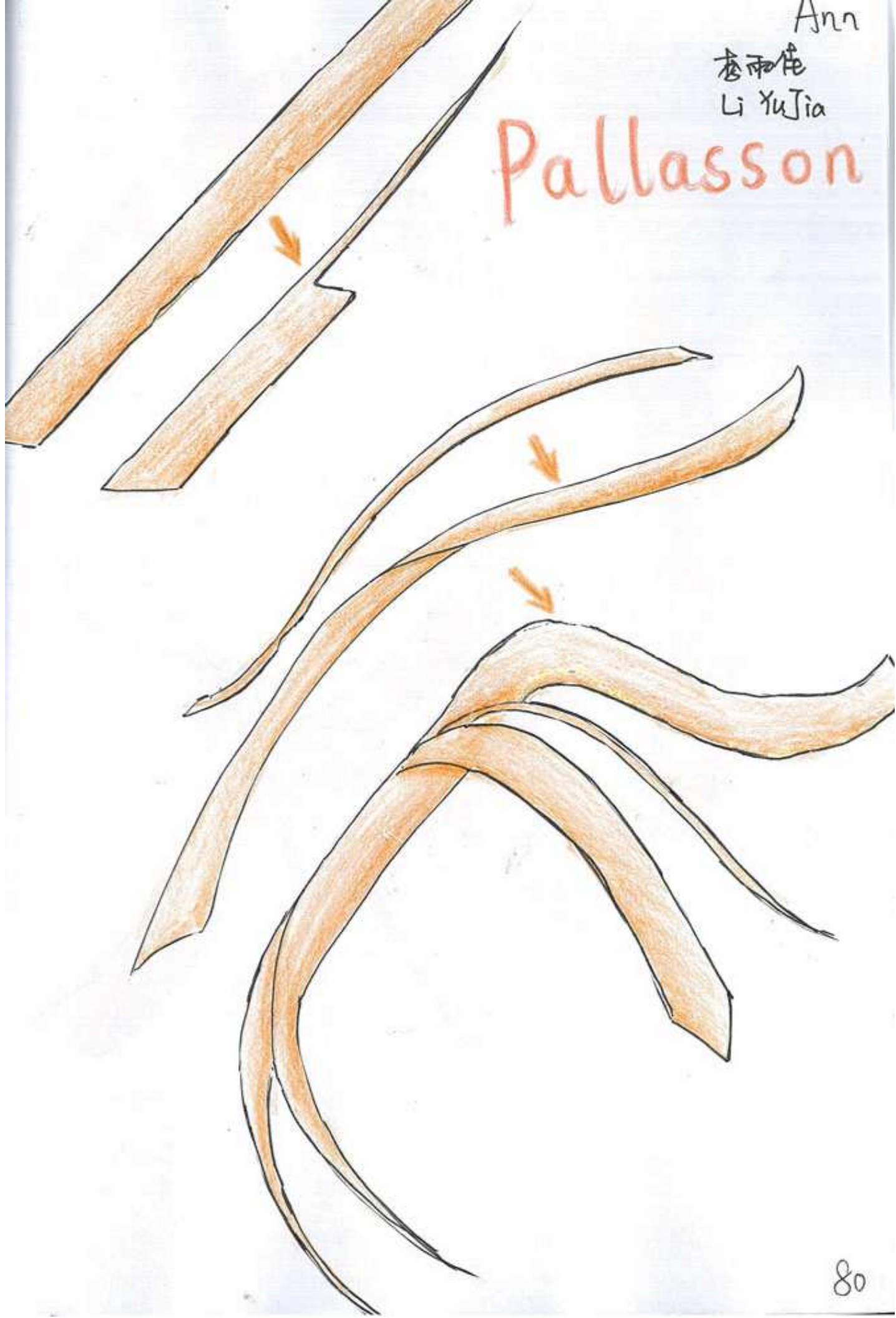

Anna

李雨佳
Li Yujia

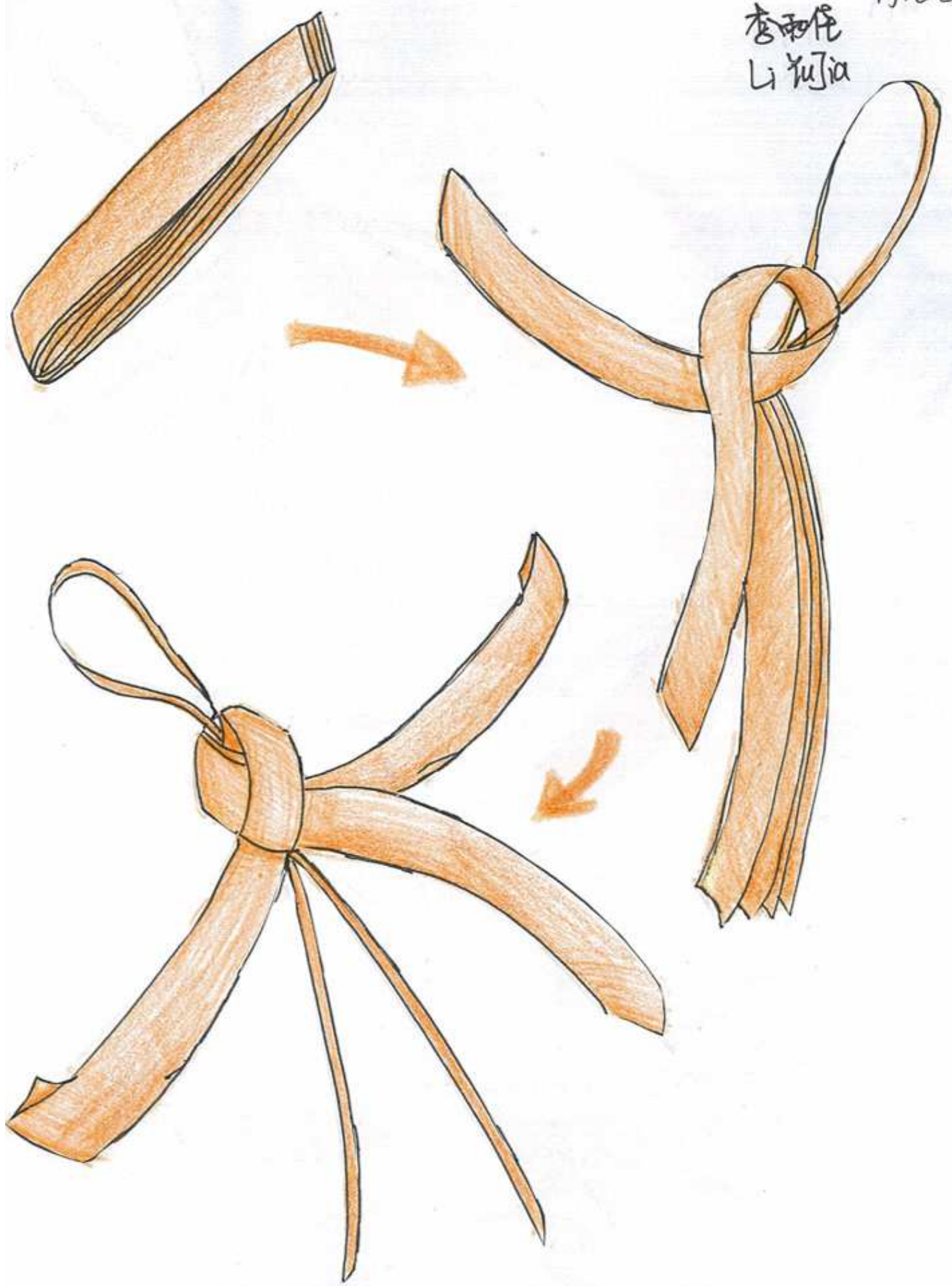

李雨佳 Ann
Li YuJia

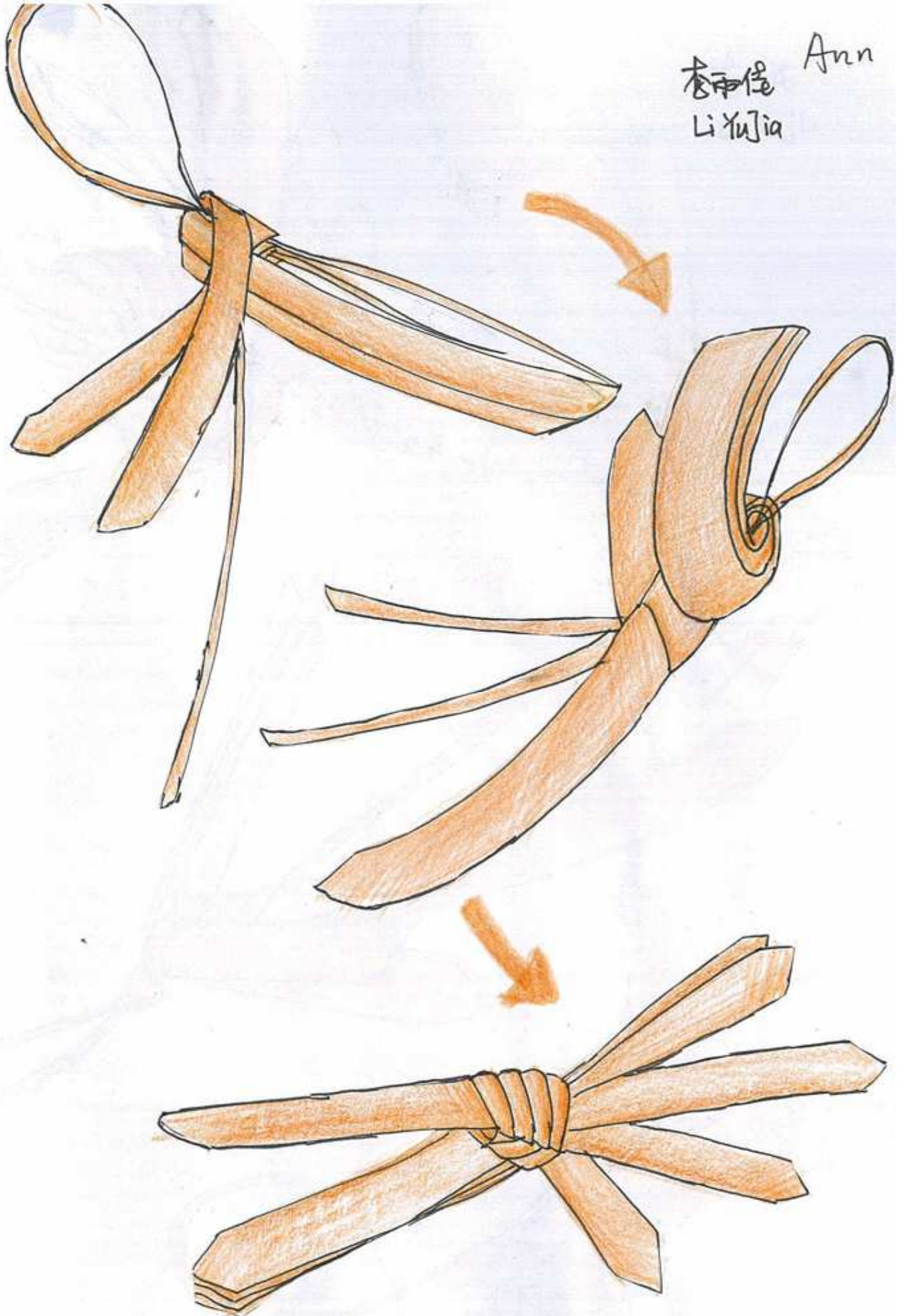

李雨佳 Ann
Li Yujia



Ann
李宇佳
Li YuJia

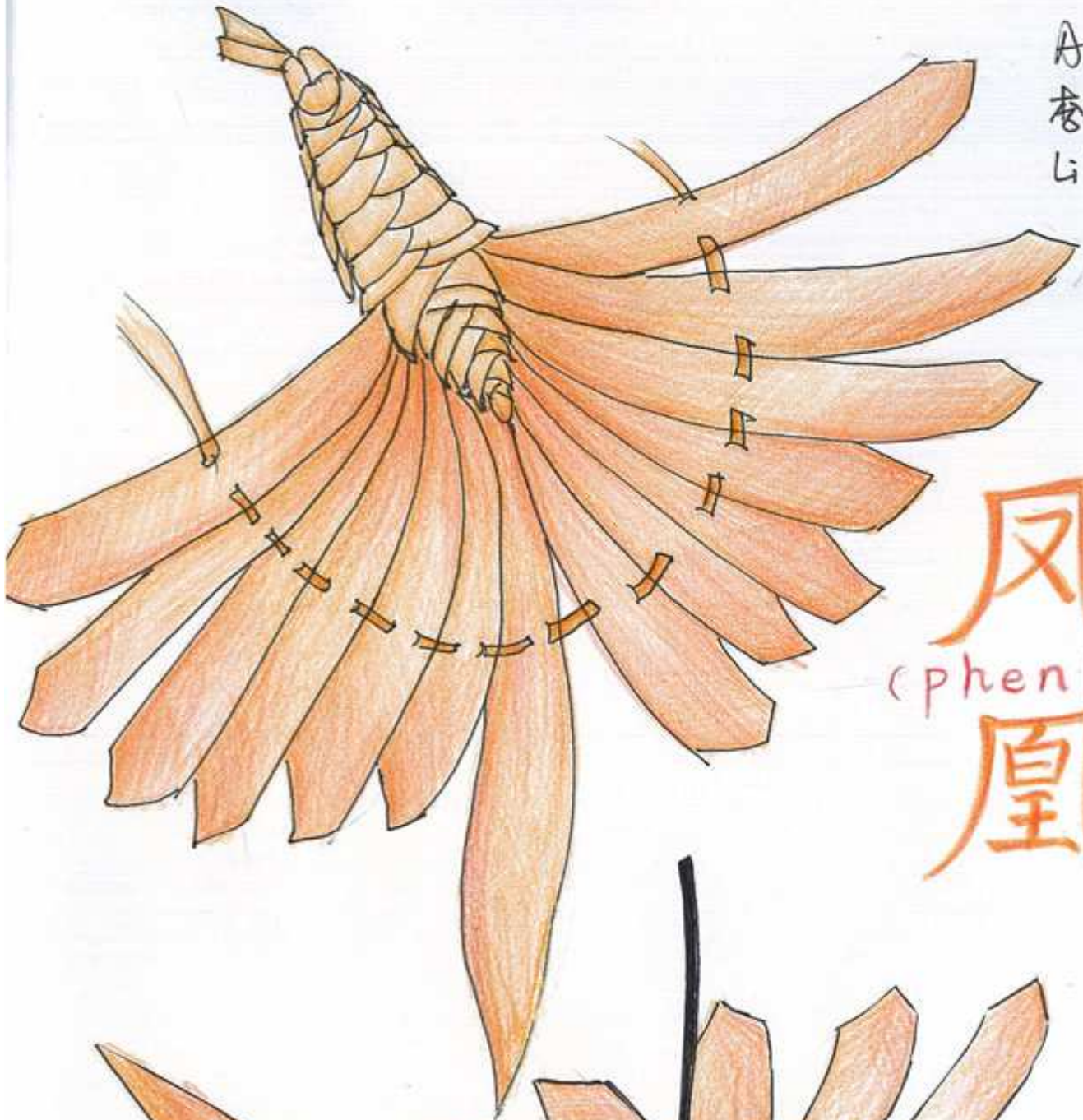

鳳
(phoenix)
凰

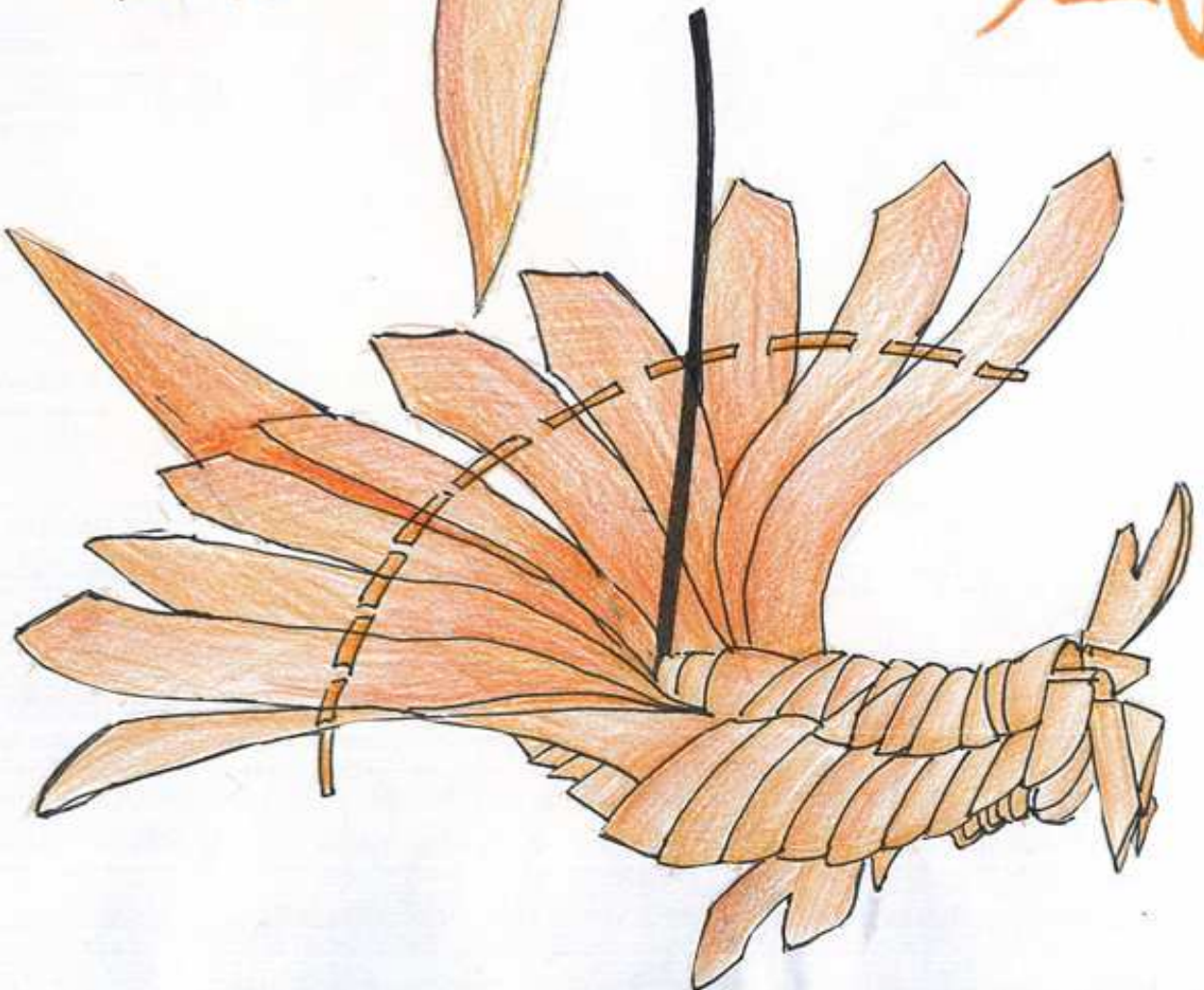

①

②

③

First get a palm leaf and cut it into 3 parts.

①

7

2 Then divide the leaf of the first part like the picture.

3

Move 1.

4

5

6

The other piece repeats the move 1.

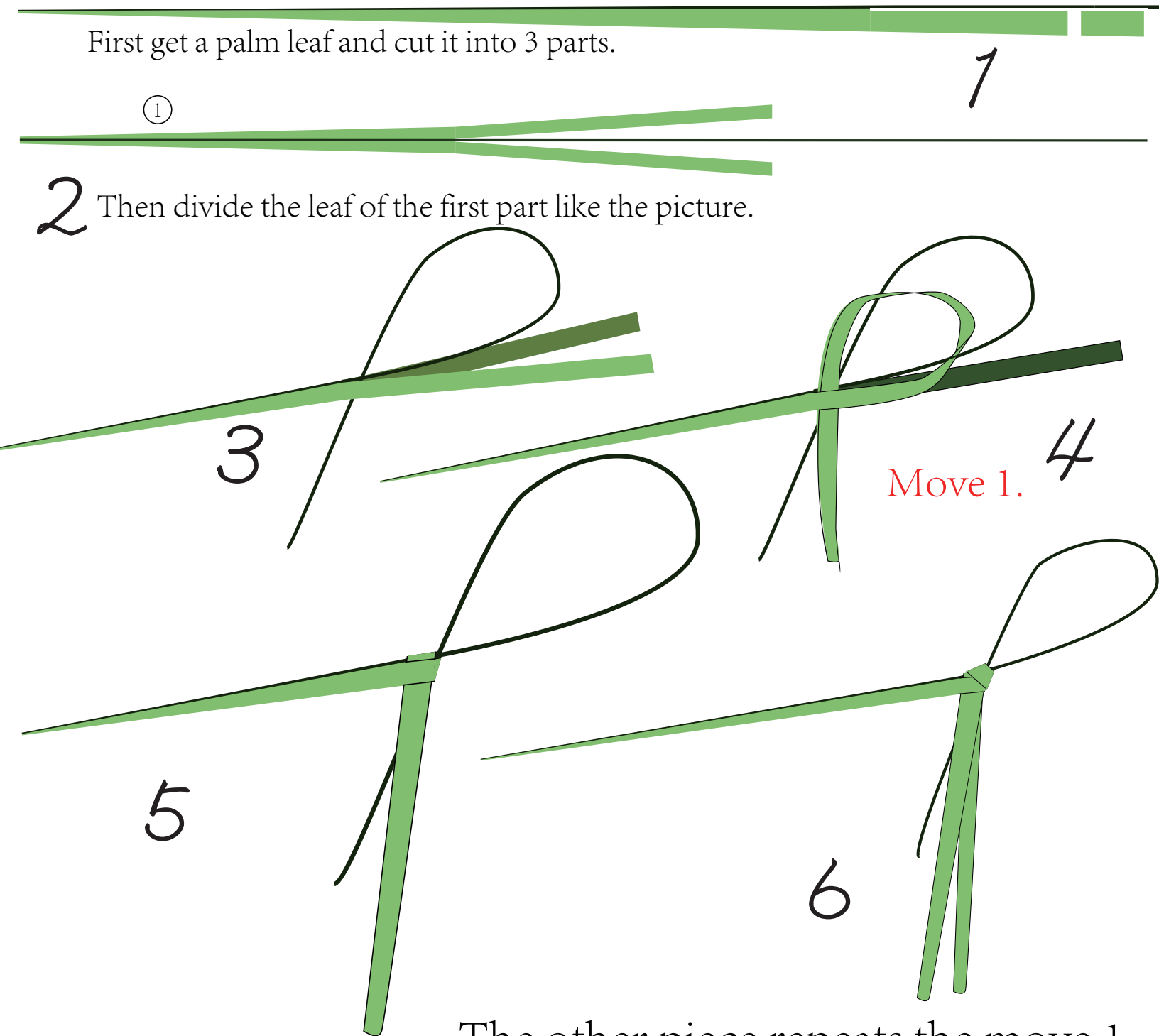

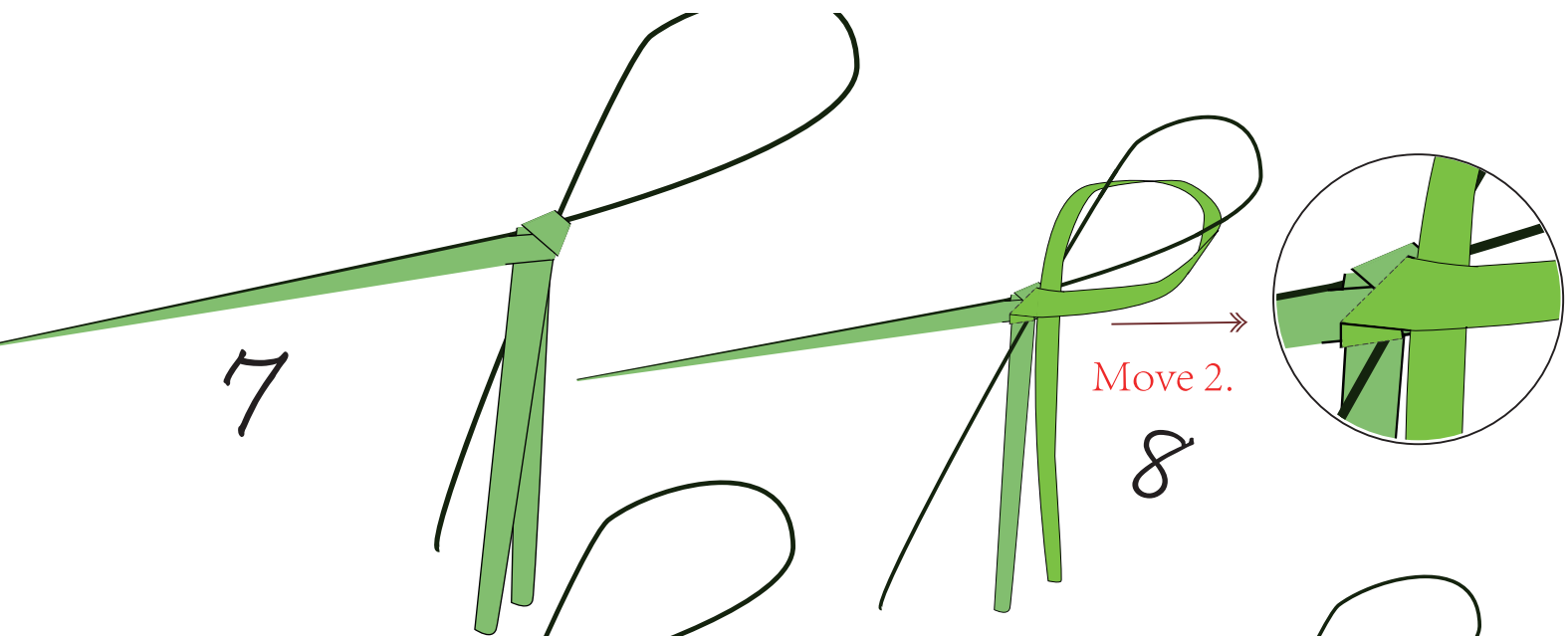

7

Move 2.

8

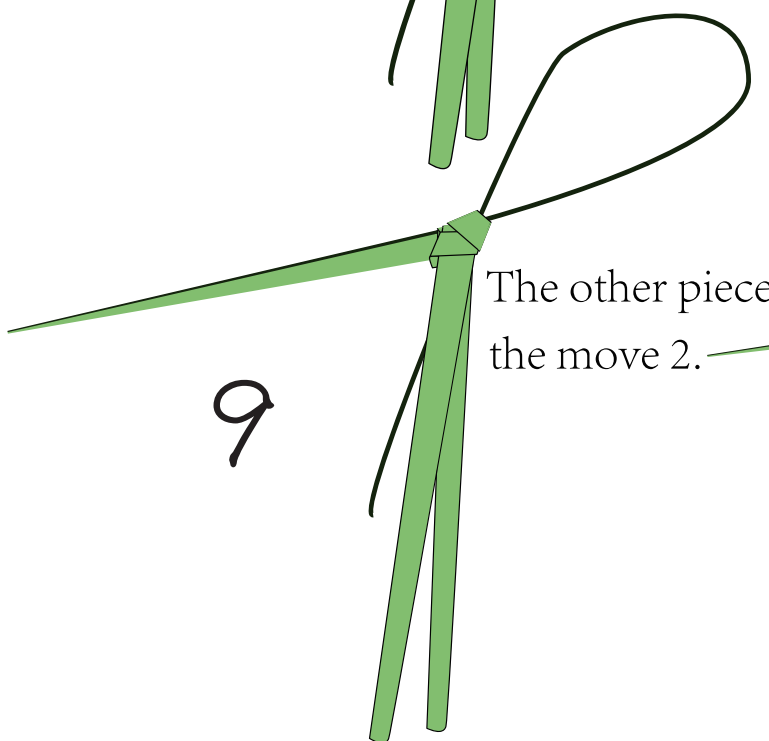

9

The other piece repeats the move 2.

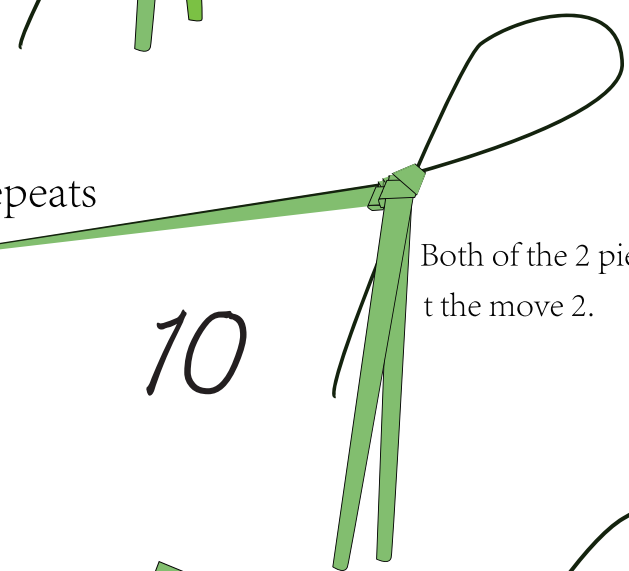

10

Both of the 2 pieces repeat the move 2.



Fold the second part of the leaf and use it as the dragonfly wings.

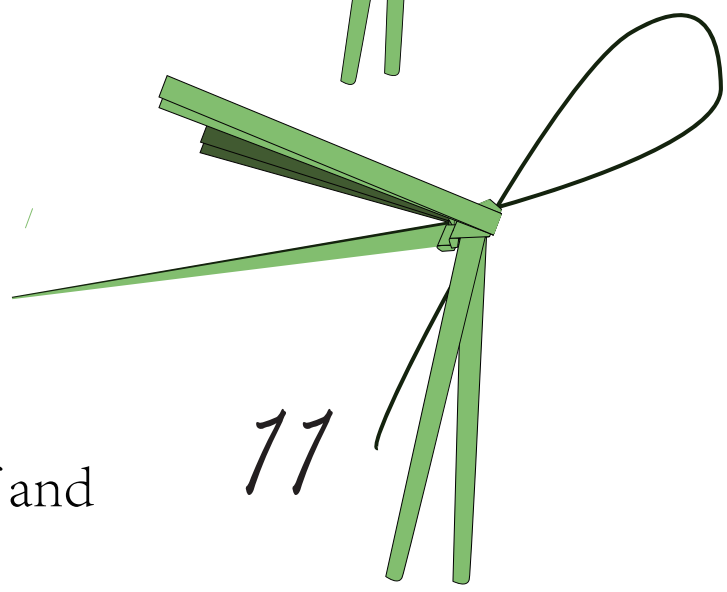
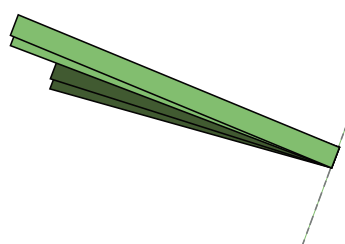

11

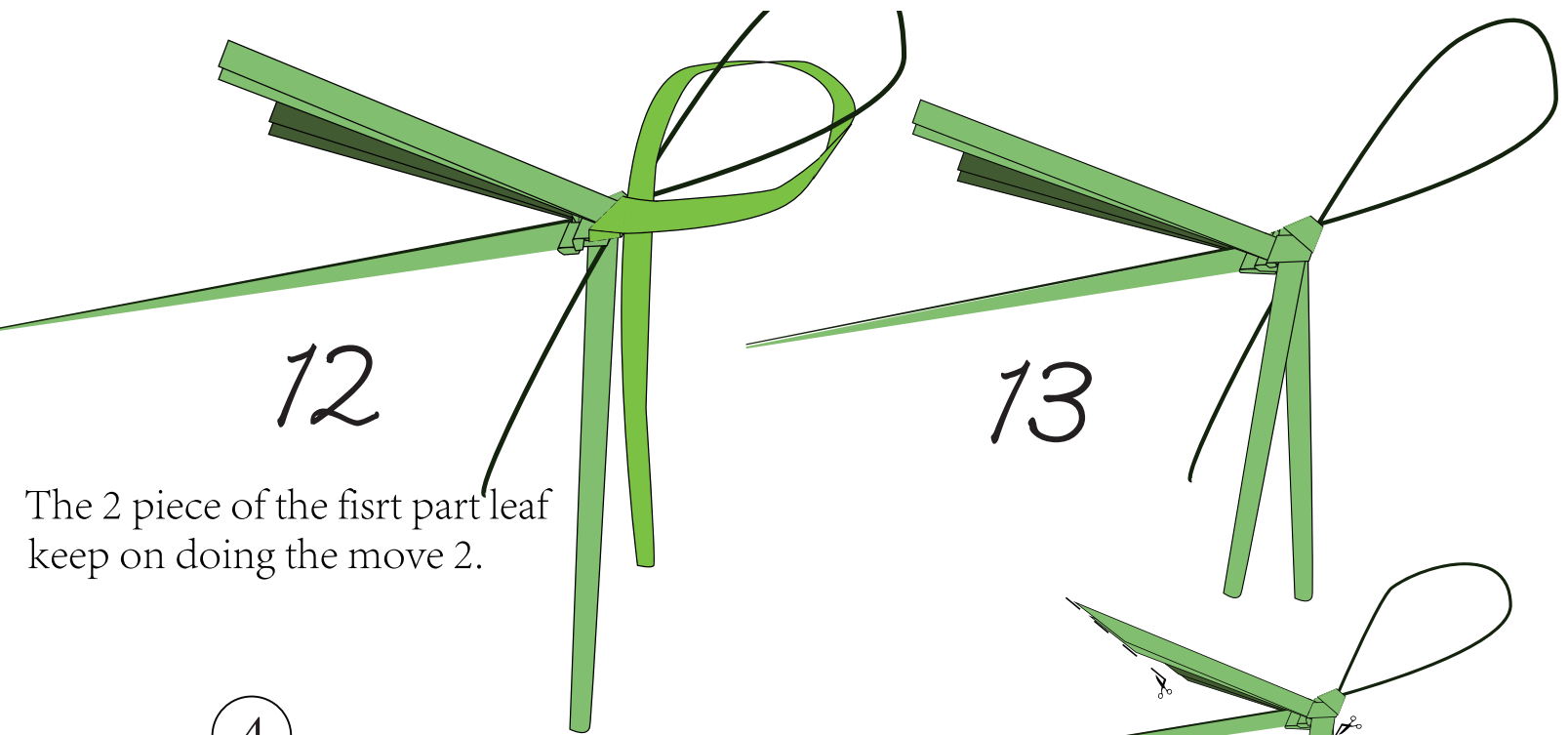

12

13

The 2 piece of the first part leaf keep on doing the move 2.

④

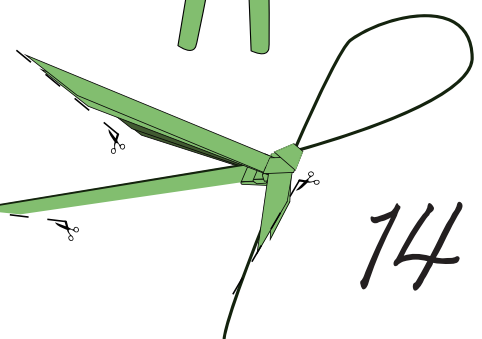

14

Use these parts that been cut off to build the upper body of the dragonfly.

Cut off the redundant part

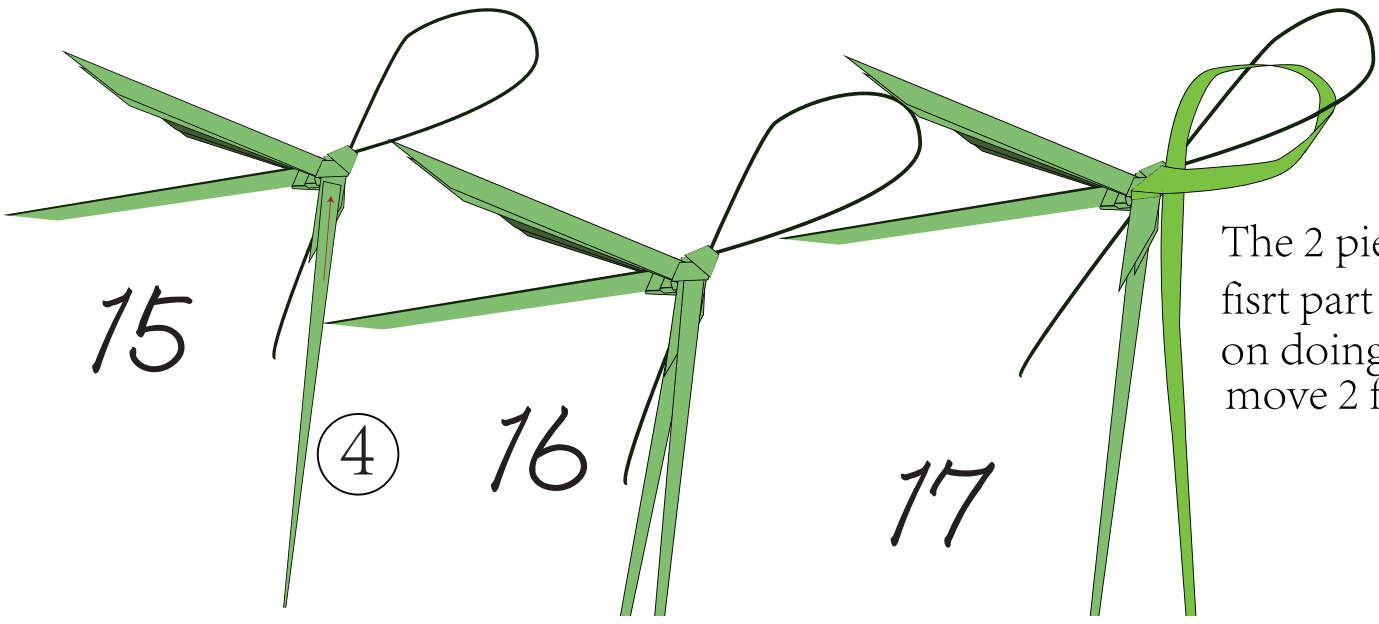

15

④

16

17

The 2 piece of the first part leaf keep on doing the move 2 for 7 times.

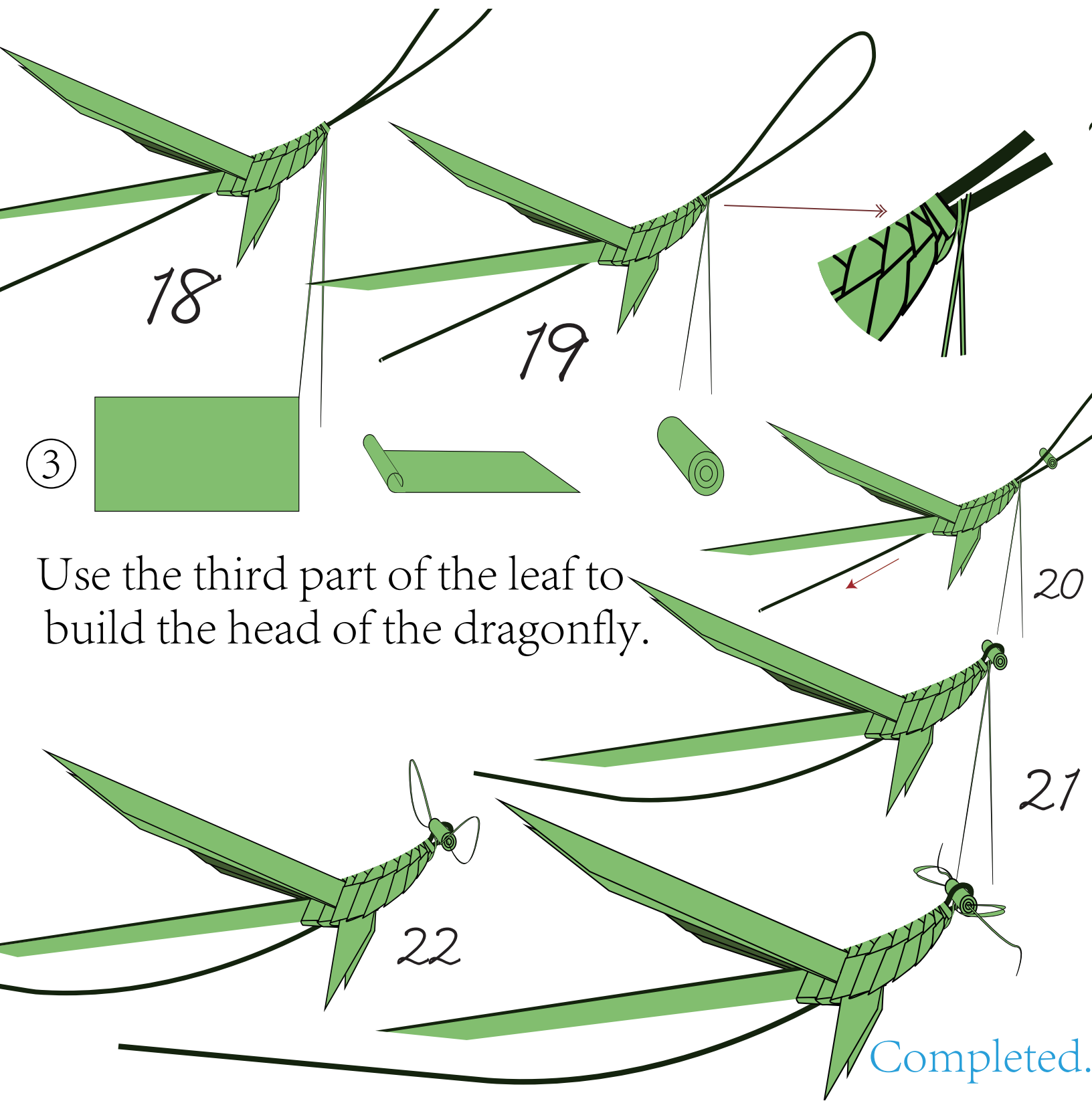

③

Use the third part of the leaf to build the head of the dragonfly.

HOW TO MAKE IT

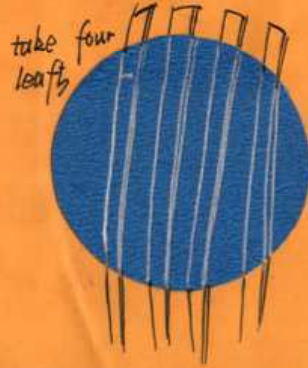
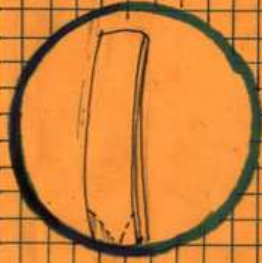

PHENIX



some things like (6)

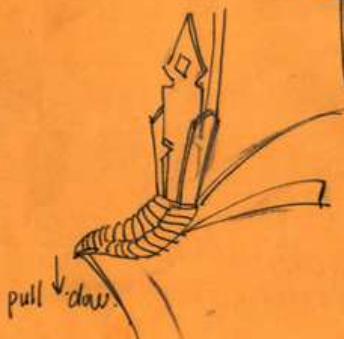

FINISH !

HOW

to

make

me

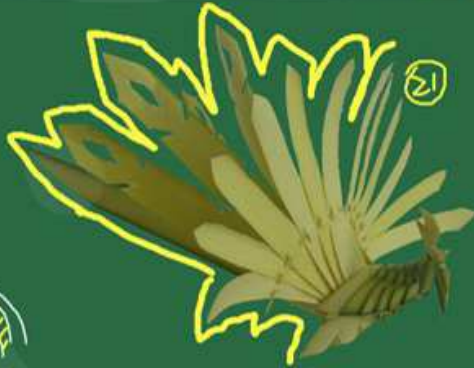
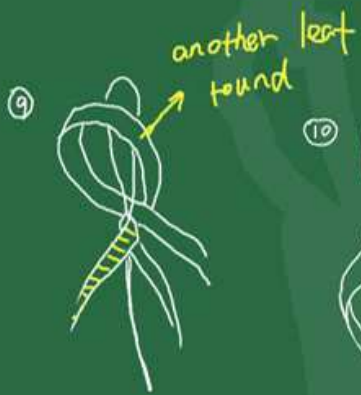
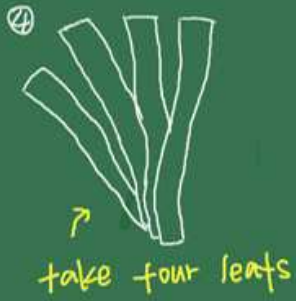
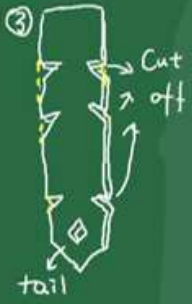
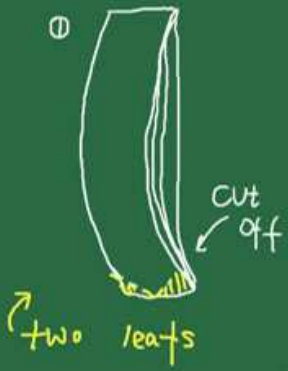

another leaf same the one



the four leaves from ④

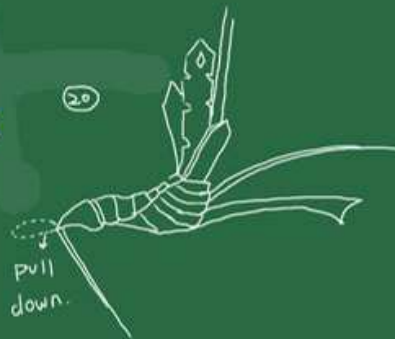
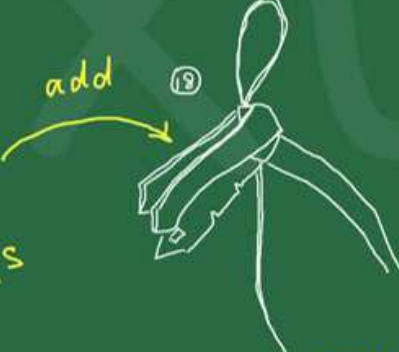

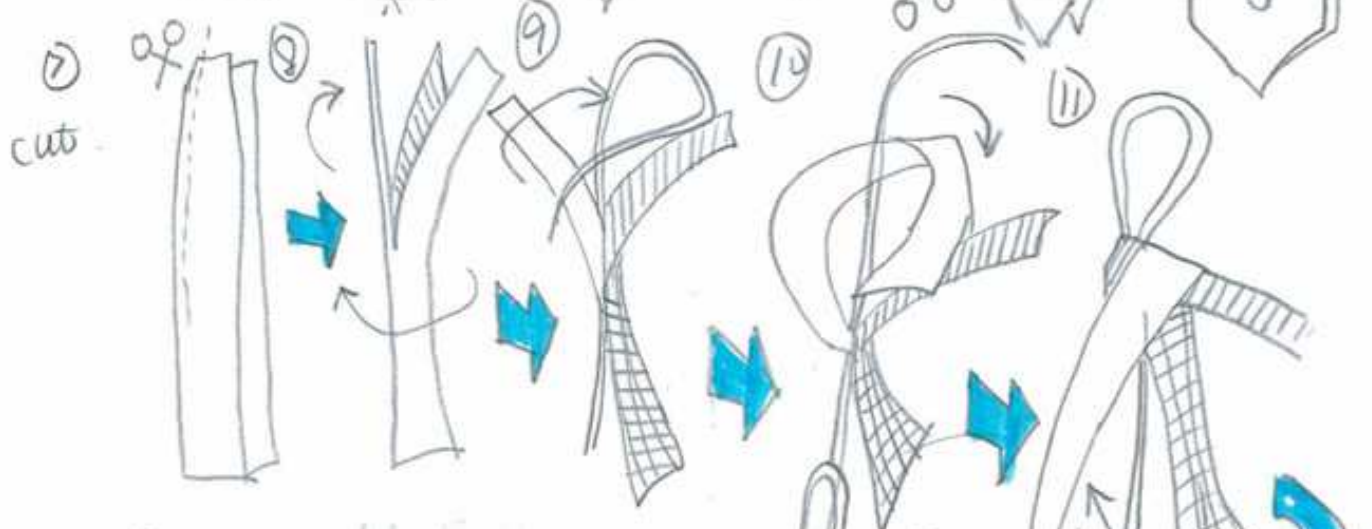

add ⑥ to ⑬

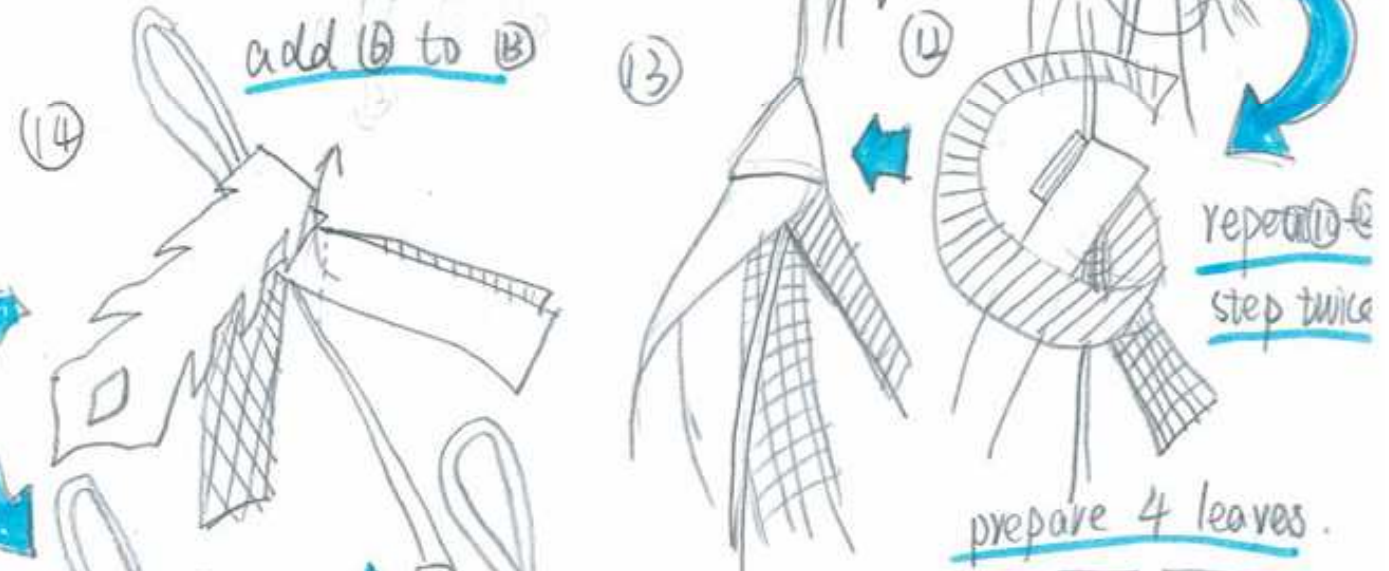

repeat step twice

prepare 4 leaves.

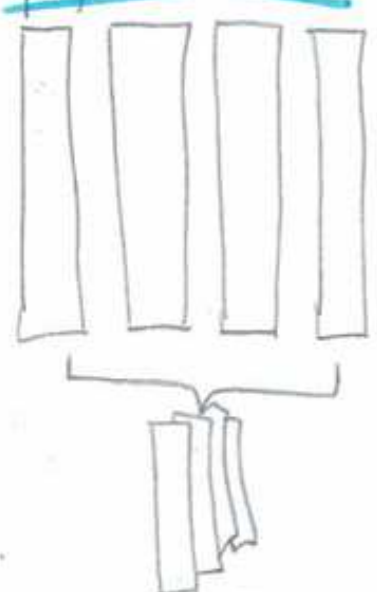

18

19

20

21

22

23

24

25



repeat 21-22
5 times

Wu Weicao
20/2050502/6

孔雀
孔雀
Finish

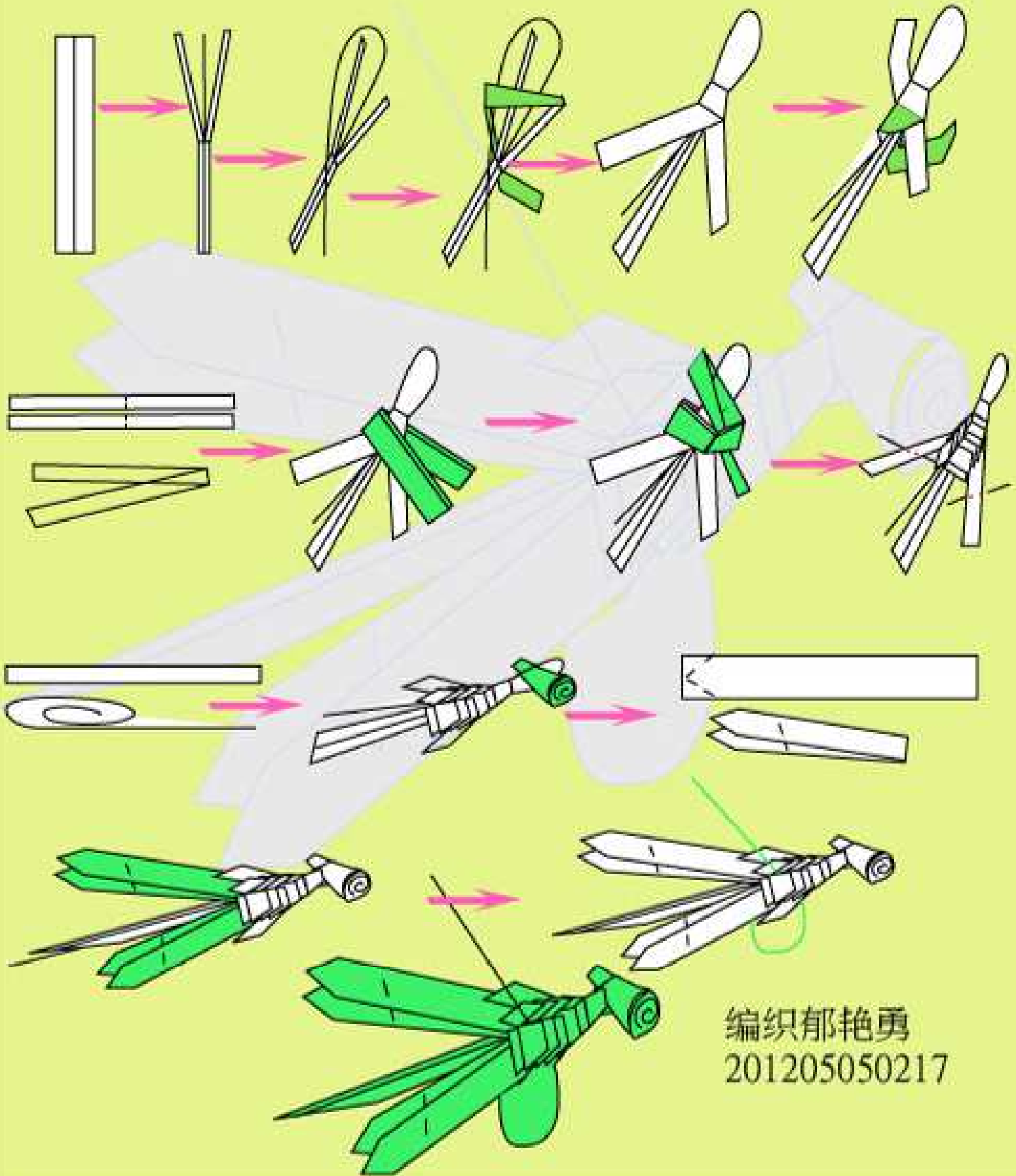

编织郁艳勇
201205050217

ROSE

Zhang Shuhao

201205050218



1- Cut the leaf of palm as the same as picture to make a stem for the rose and a strip for petal.



2- Start on the left end of the leaf strips. Take them and fold them one by one in to make the shape of a triangle. The fold must be downwards about 20 millimeter (45 degree angle).

4- wrap it around the stem that you started with in the beginning.



3- Start wrapping the leaf strips inwards by each time folding, this will be your rose center roll.



5- Take another palm leaf to cut rose leaves and put them in the stem part.

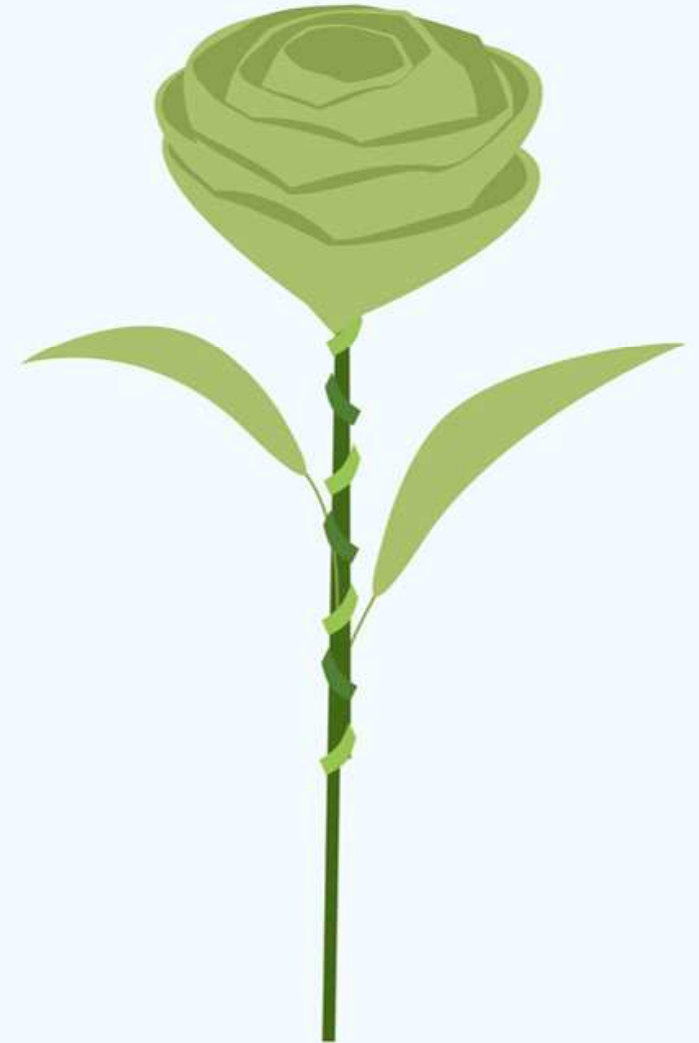

Palm Rose Folding Instructions



Let's start by Rose. Skill of gift wrapping adds much value to any occasion while presenting a gift to gift receivers. They make cute gifts on Mother's Day, Birthday and so on. This is a step by step guide on making a rose with palm leaf.



1- Cut the leaf of palm as the same as picture to make a stem for the rose and a strip for petal.

2- Start on the right end of the leaf strips.

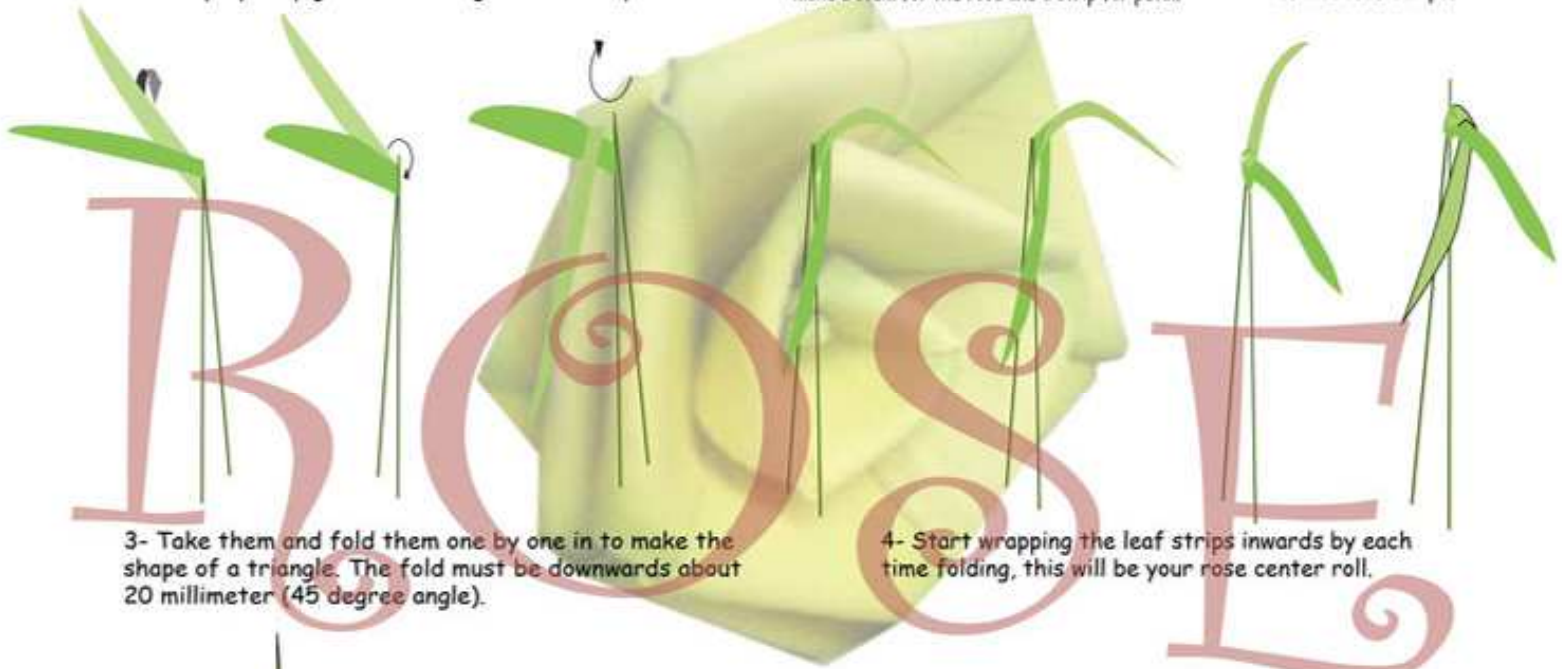

3- Take them and fold them one by one in to make the shape of a triangle. The fold must be downwards about 20 millimeter (45 degree angle).

4- Start wrapping the leaf strips inwards by each time folding, this will be your rose center roll.



6- Shape it into a rose as you go. Keeping the top fold, wrap the leaf strip around. Be sure to keep the top of the ribbons at the same height.

5- Start by taking the long end, and fold them backwards, and wrap it around the center. While one hand is wrapping, make sure the other hand is holding the bottom stem part. Never let the stem go, or it will become loose.

7- Repeat until you have about 20 centimeter of tapes left (which is the end of palm leaf and more narrow), fold it in half, and wrap it around the stem that you started with in the beginning.

8- You wrap the narrow part of tape around the stem till end of strip. And tie it so that it will not loosen. Take another palm leaf to cut rose leaves and put them in the stem part.

Grasshopper Talk

Industry Design Class 2
201205050220
Xueqi Zhou

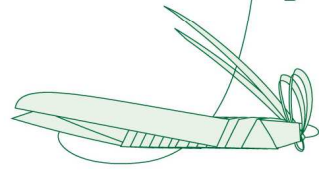

1 Cut the leaf of palm as the same as picture to make the Grasshopper's body and share half of the midrib of leaf.

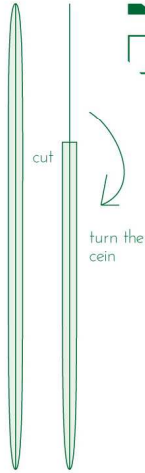

2 Start on the middle of the leaf strips.

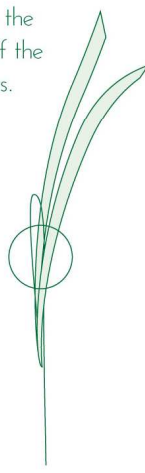

3 Take the midrib of leaf to roll it like circle and tie the two strips of leaf on midribs one by one on the rolled midrib to make the shape of a Grasshopper body.

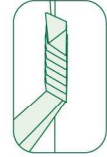
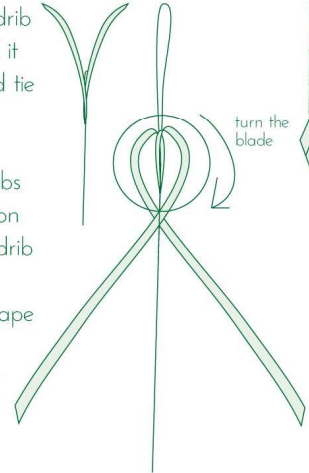

add two blade and do again



4 After 5 ties, prepare 2 strips and fold them from the middle side then put them on the body of Grasshopper (for purpose of wings) and tie the main two strips . Again After one tie, prepare 1 strip and fold them from the middle side then put it on the body of Grasshopper (for purpose of legs) and tie the main two strips to finish the form of Grasshopper body. Cut the tail of Grasshopper.

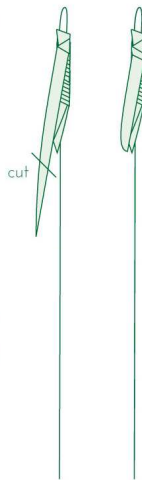

5 Make the mouth. While one hand is working, make sure the other hand is holding the body part. Never let it go, or it will become loose.

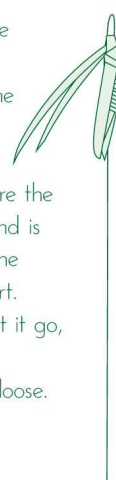

Go through the ring

Final result

6 with remain parts of main trips make the head and put it in site the rolled midrib and tighten it.

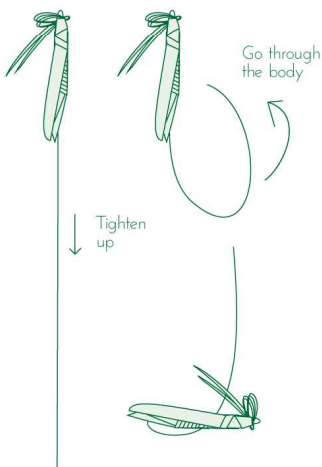

BIRD

• Part 1.

Instrument

1.



Scissor

工具：- 一把剪刀。

- 一根针

- 一根的棕叶。

Sewing needle

2.



3.



Palm leaf.

•• Part 2

1.1



将棕叶对折



1.2



将棕叶的茎用针挑开，在叶尖部留一小截

2.1

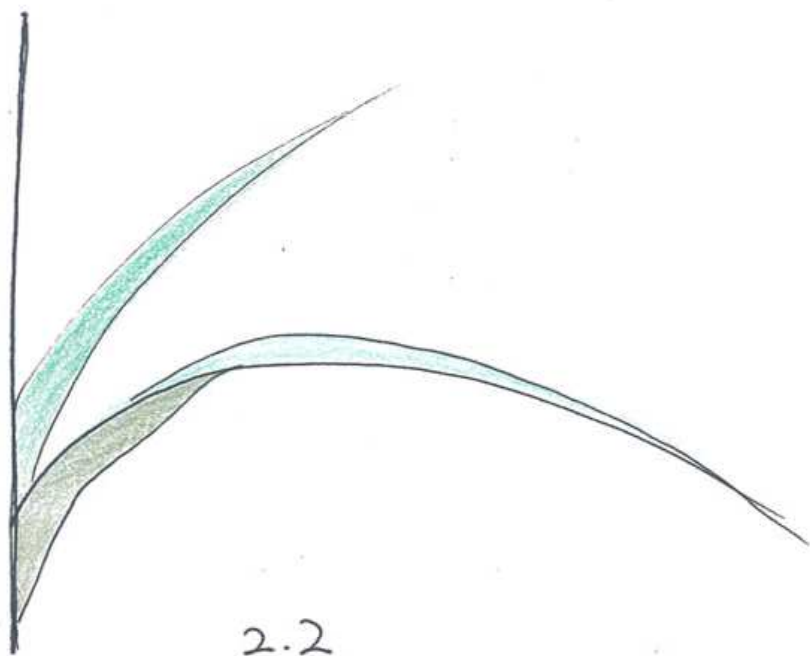

2.3

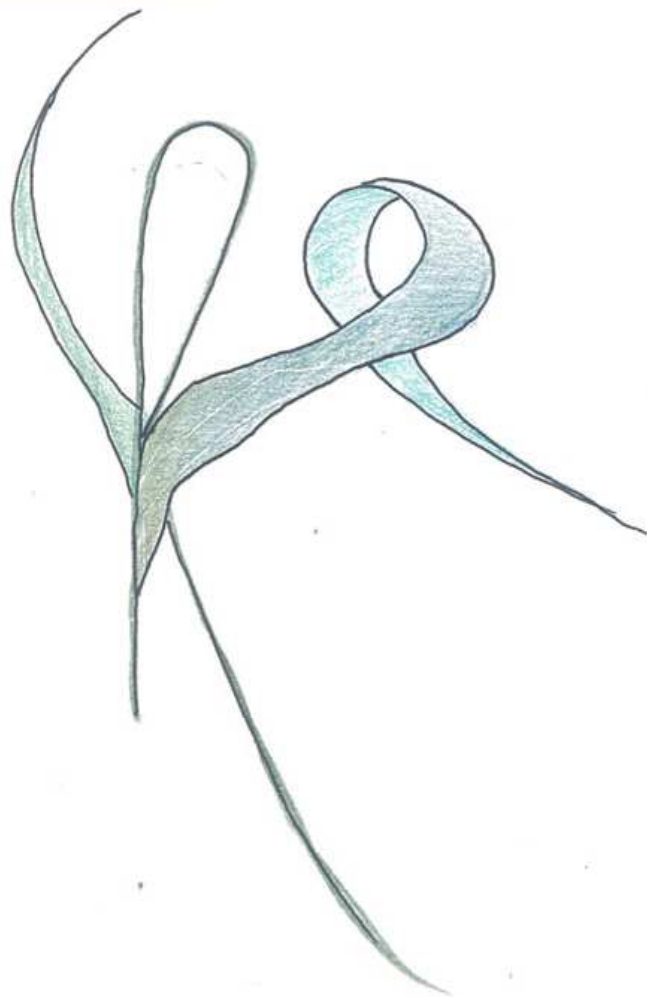

2.2

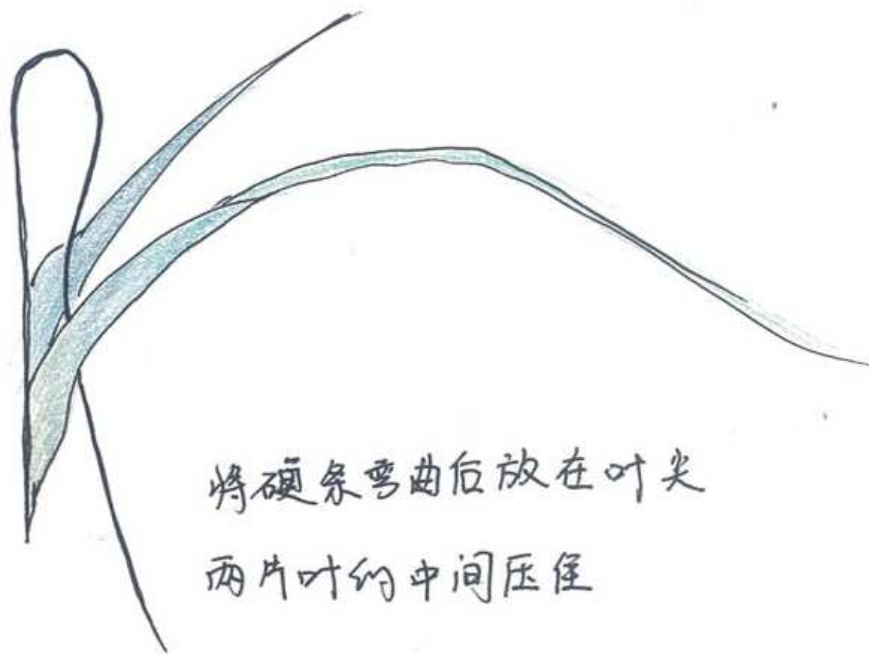

将硬条弯曲后放在叶尖
两片叶的中间压住

2.4

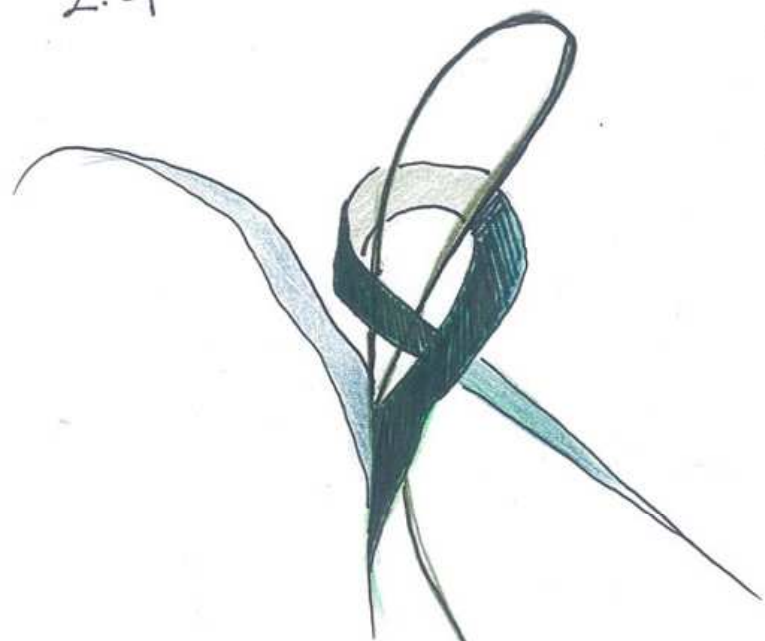

先把右边叶条打一个圈，套住打折的硬条，拉紧。

2.5

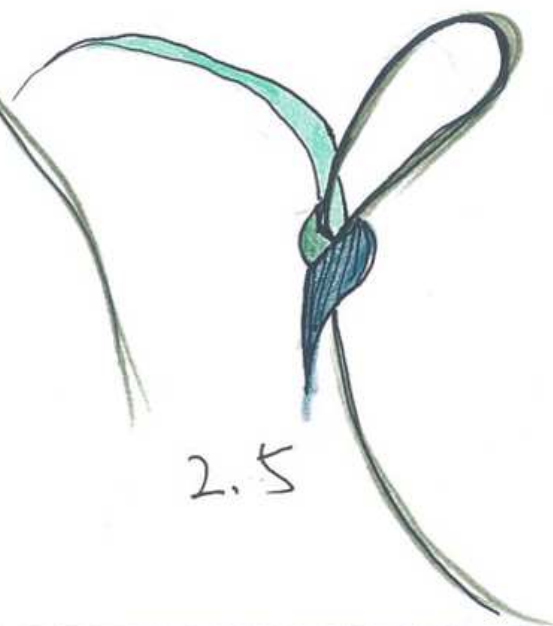

3.1

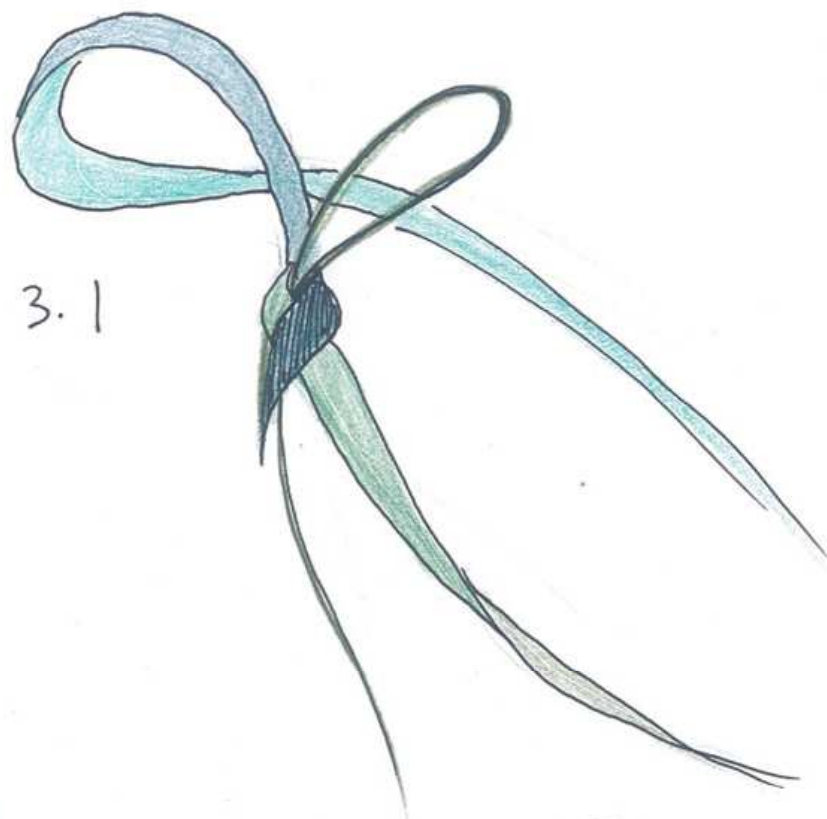

3.2



用同样的方法将左边的叶条套穿拉紧。

... Part 3.

3.3

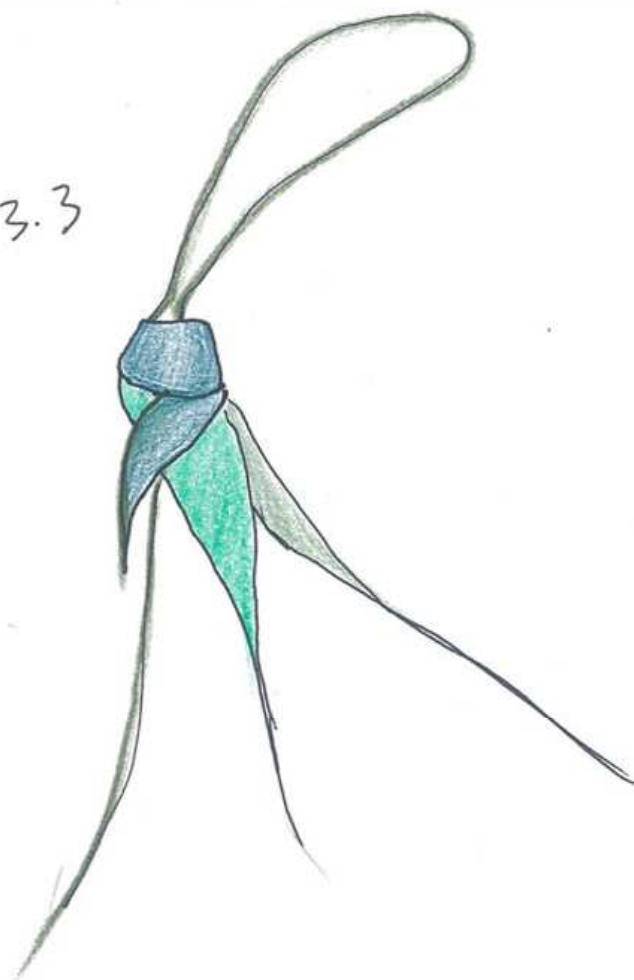

1.1

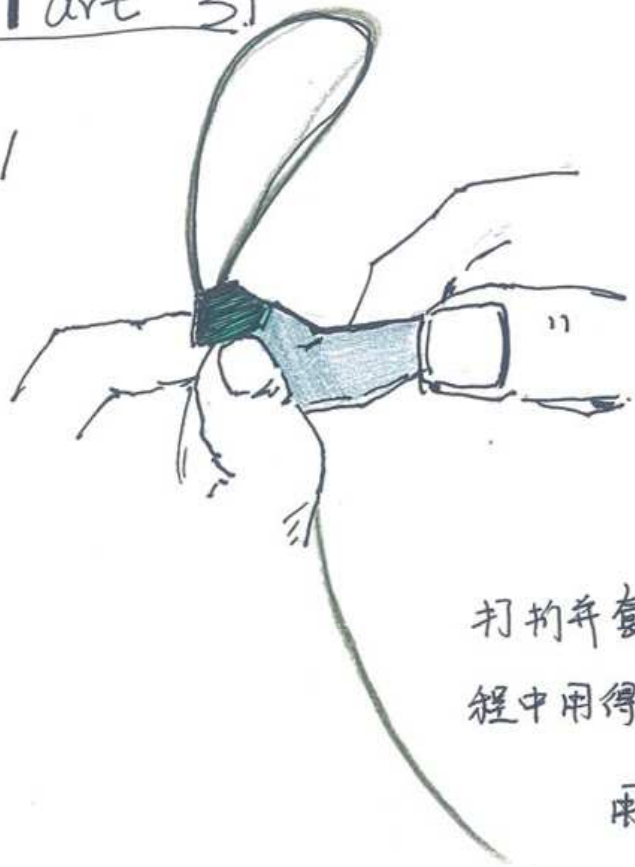

打扣并套穿是整个编绳过程中用得最多的手法。

1.2

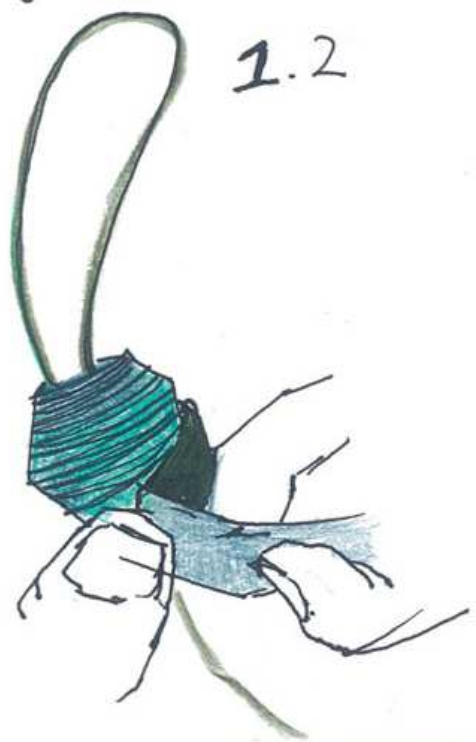

用左手握紧第一步套穿的结，右手拉开耳朵逆时针往左手握的结，平放为折。

折叠后用左手大拇指压平然后套住硬条，拉紧。

2.1

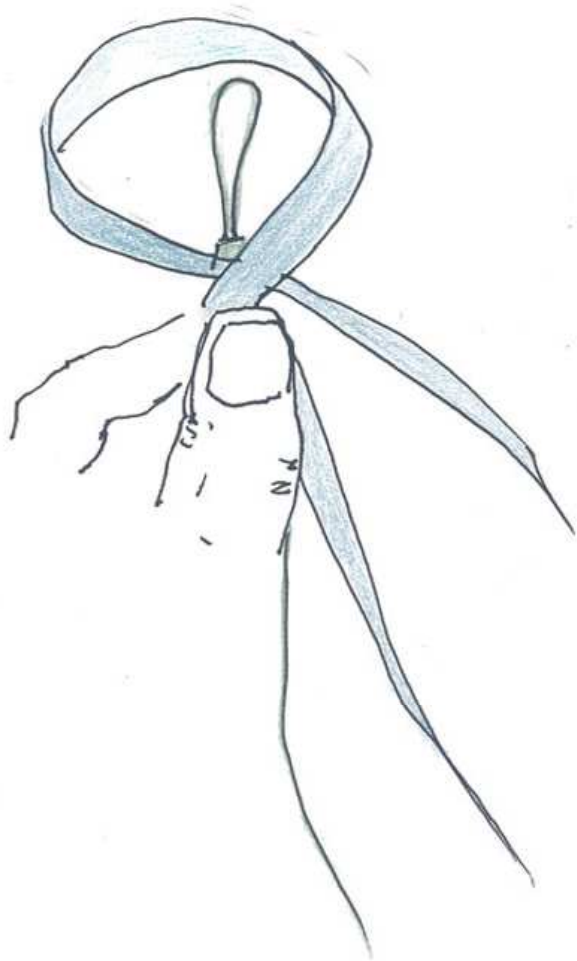

2.2

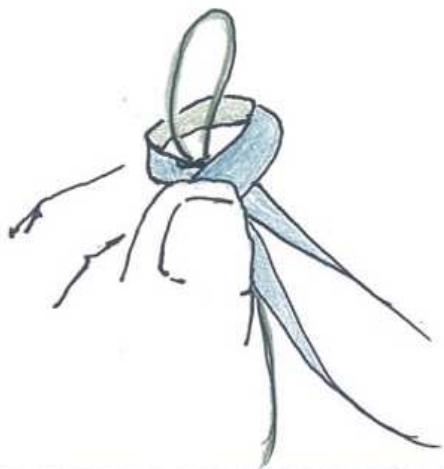

3.1

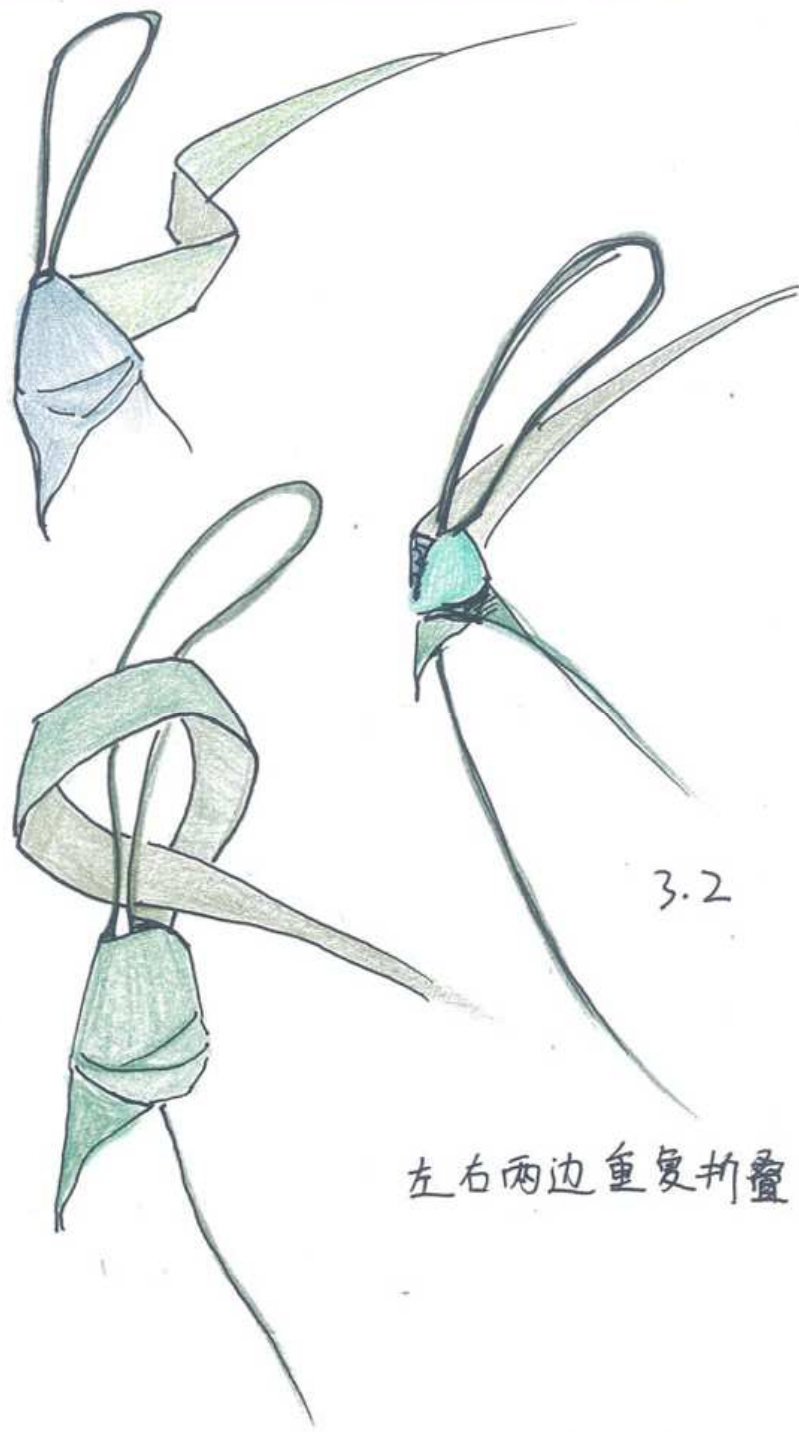

3.2

3.3

左右两边重复折叠

4.

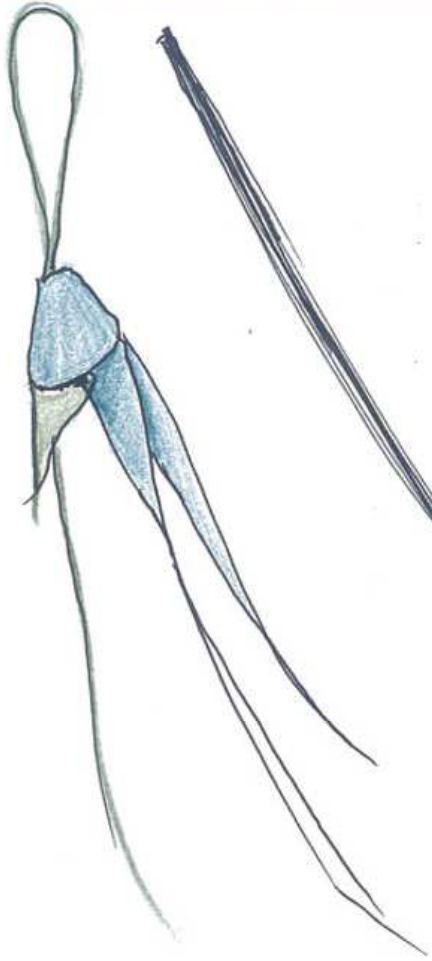

5.1

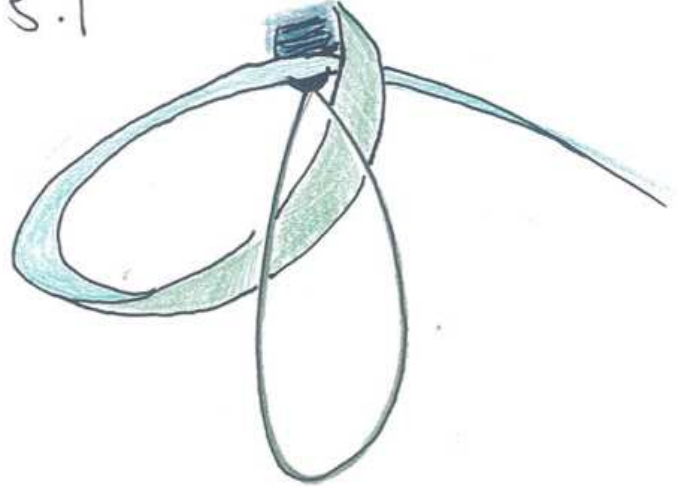

5.2

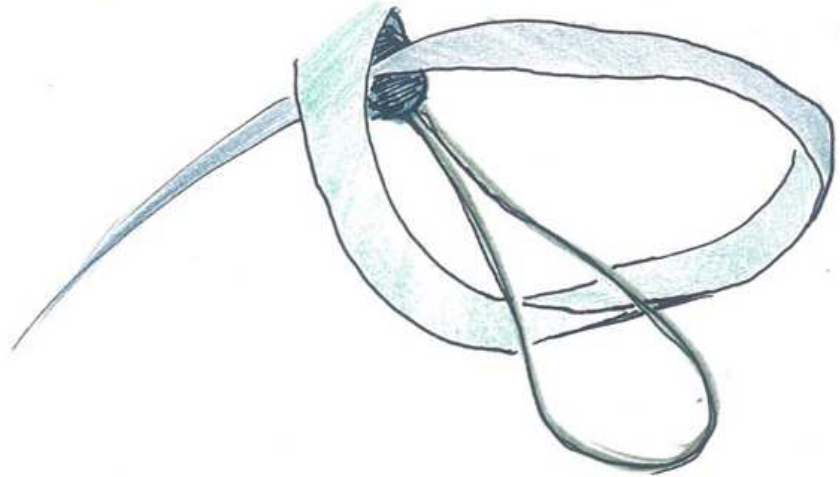

..... Part 4.1

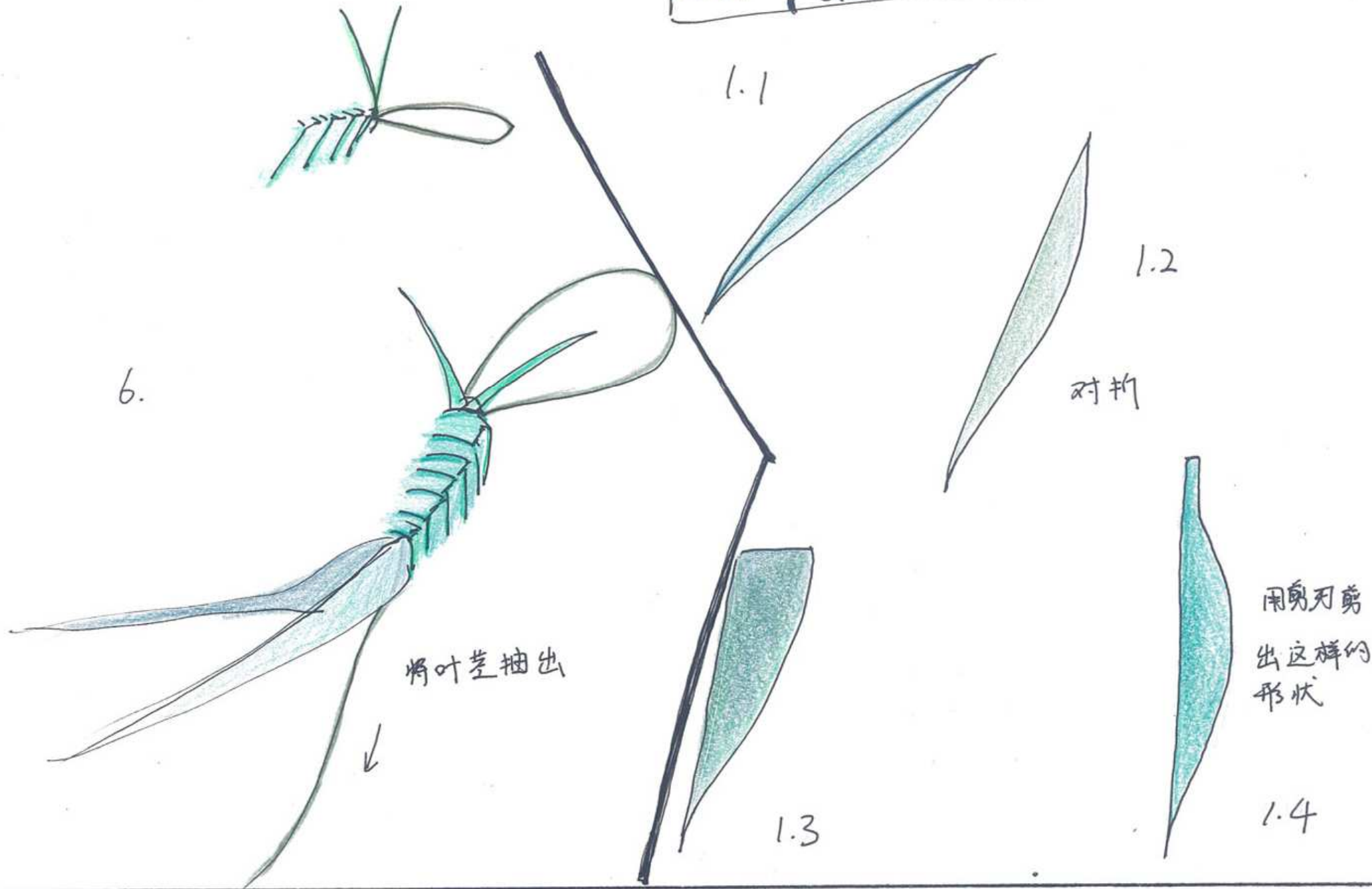

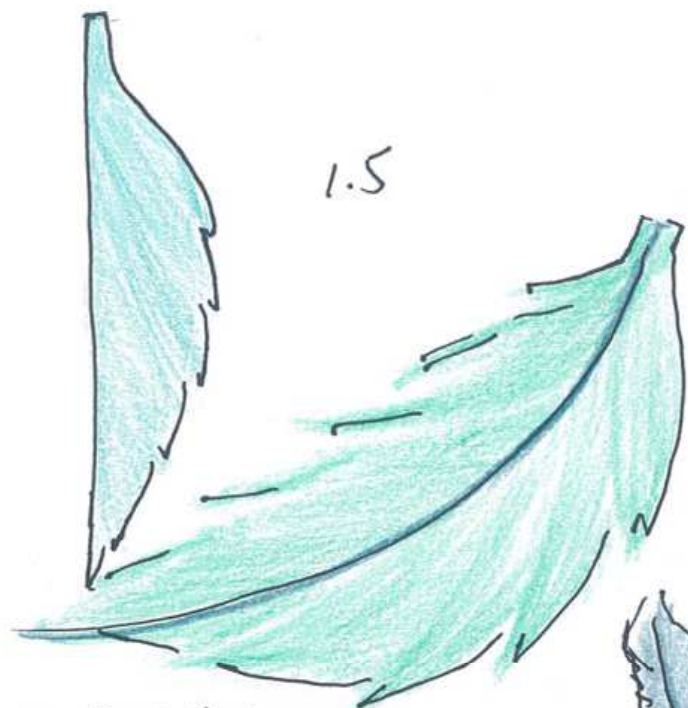

1.5

用剪刀剪出羽毛的边缘。

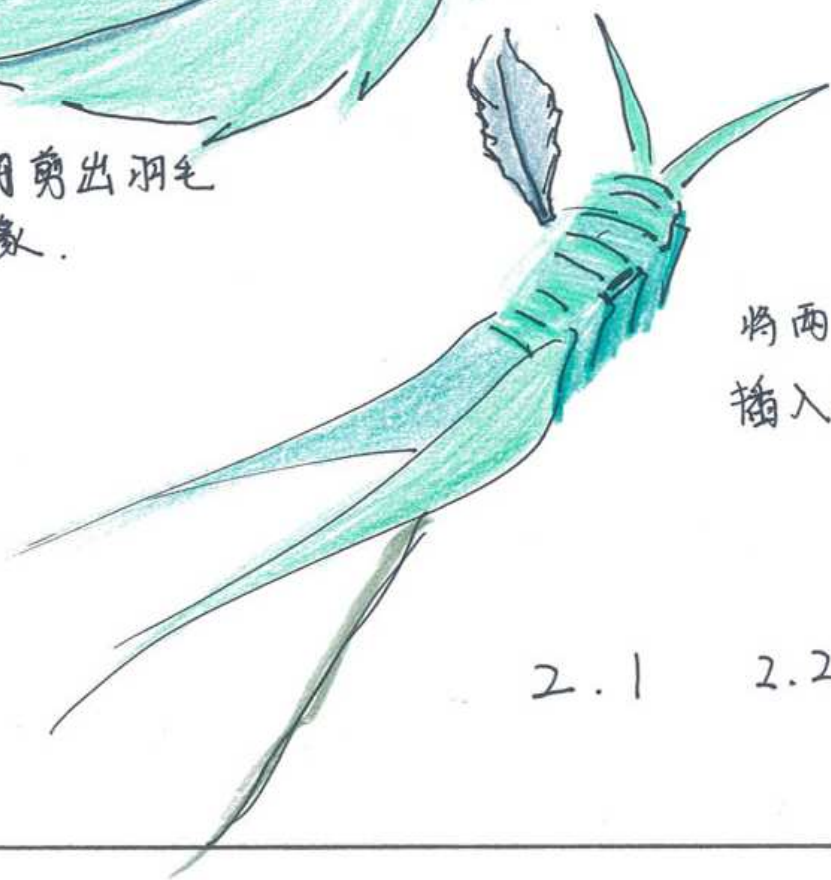

2.1

2.2

将两片羽毛插入小鸟的两侧缝隙。

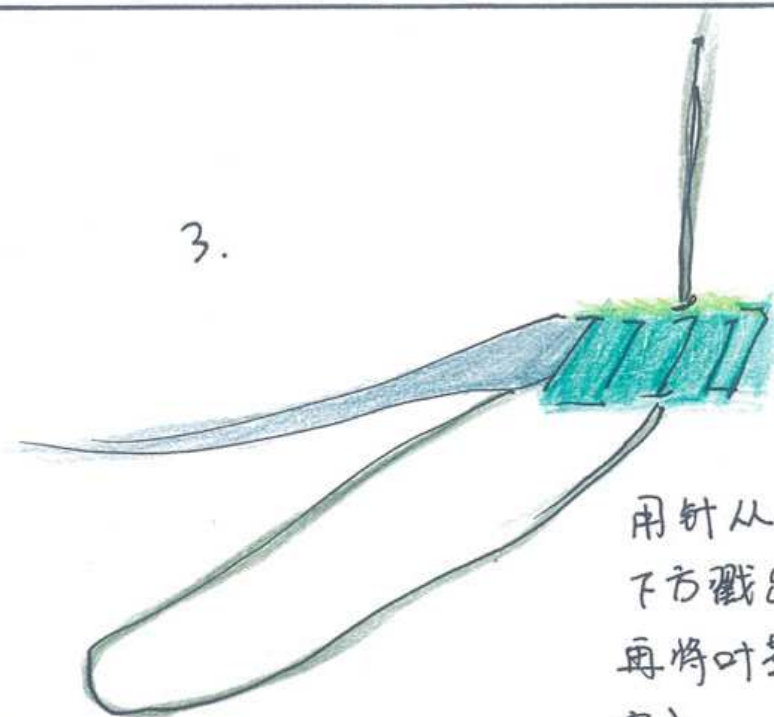

3.

用针从小鸟身体下方戳出一个小孔，再将叶茎从孔中穿入。





ROSE

MATERIAL:

- Bamboo leaves * 4
- Scissor *1
- String *1

You need 2 pieces of bamboo leaves



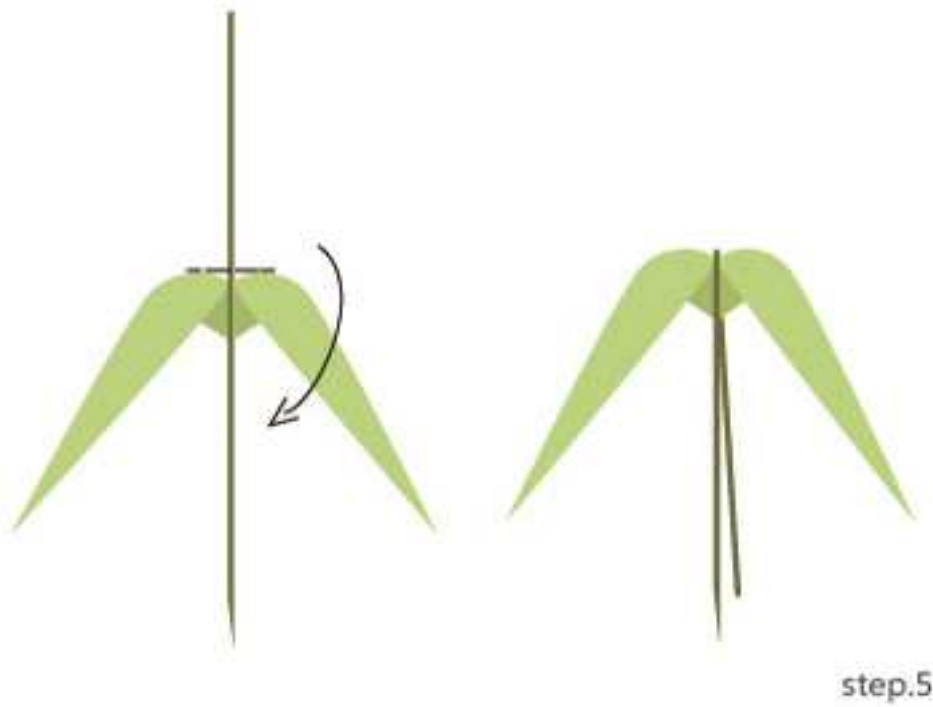
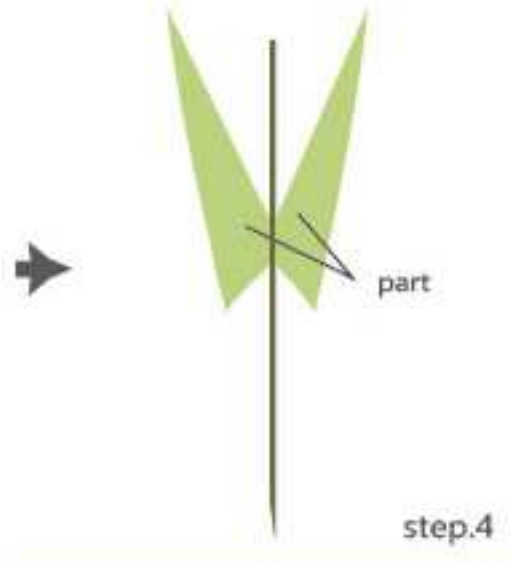
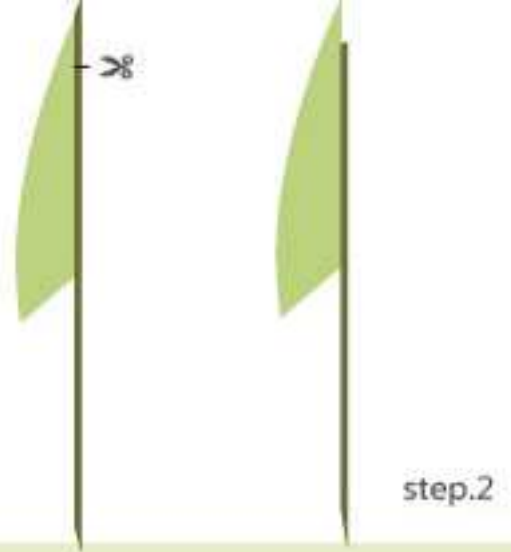
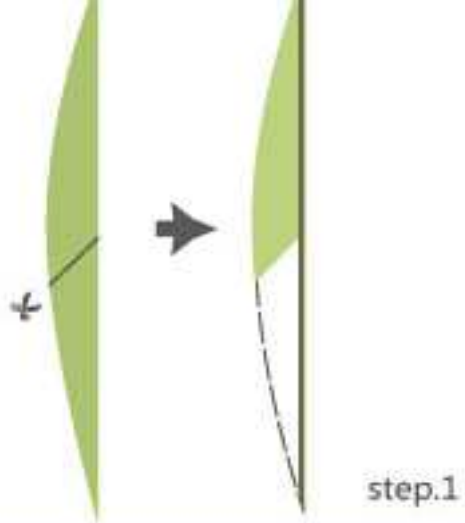

concrete steps



step.6

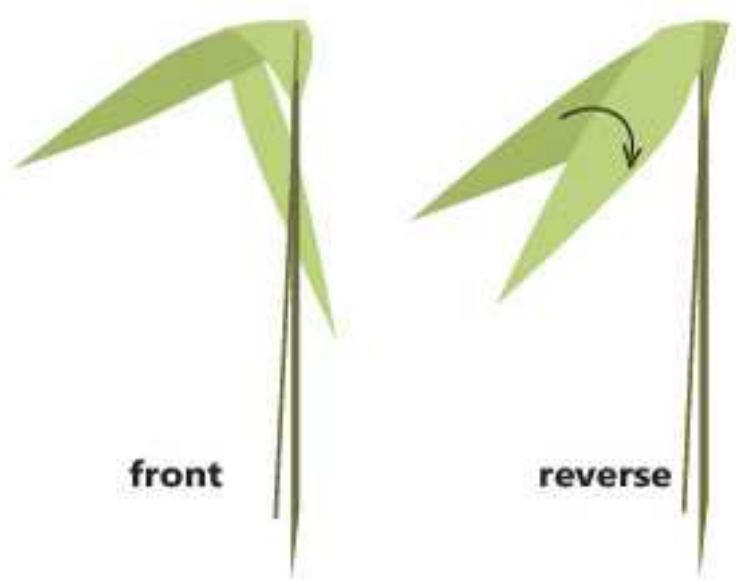

front

reverse



step.7



step.8

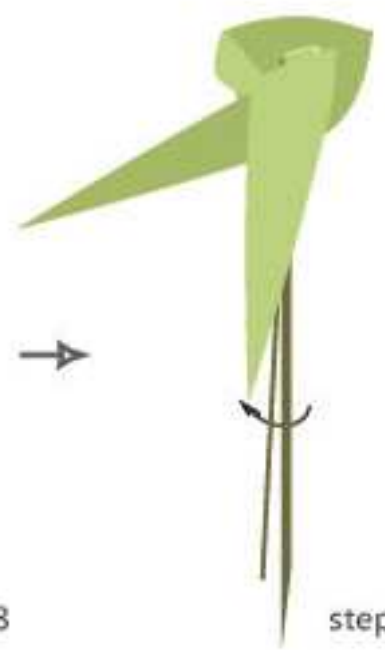

step.9

The side folding side rotation

The leaves above the pressure below the leaves



And so on

This step may repeat 15

If you want a big flowers, more steps in duplicate



step.10

The two leaf cross winding

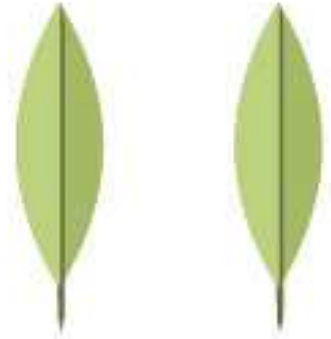

step.11

you need 2 pieces of bamboo leaves



step.12

Find the right position, leaves will be inserted into the stem

END

Make a flower with leaf

ZhuFeng
201205050223

1.



find a long leaf

2.



fold it and cut along this dotted line

3.



throw it away

4.



dimidiation

5.



turn one side

6.



fold the shaft

7.



turn over one side around another one

8.



turn around the shaft

9.



turn over another side

10.



go on with 1 and 2



do these 2 steps again and again

11.



done the petal and twine the rest of the leaf

12.



in the end, insert two leaves, you finished a flower!!

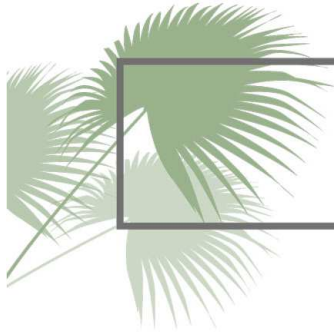

Craft about palm leaf

Bird

Body



1. Separation midrib

Separation midrib as same as picture above. Now we have two leaf strips.



2. Curve midrib

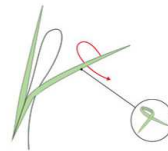

3. Curve leaf



4. Roll midrib

Take the midrib of leaf to roll it like circle.

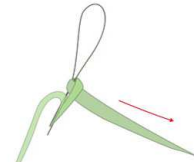

5. Tie the one strips

Tie the one strips of leaf on midrib one by one on the rolled midrib to make the shape of a Bird body.

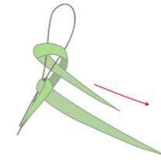

6. Tie the other strips

Tie the other strips of leaf as same step 5.



7. fold leaf as same as picture



8. Repeat steps 4-7 about 8 times

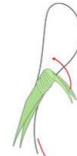

9. Curve midrib

Curve midrib and tie it as same as above.



10. Finish

Wings



1. Use a strips of palm leaf

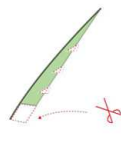

2. Cut palm leaf as same as above picture

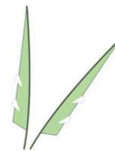

2. Repeat steps 1-2 make other one

Whole

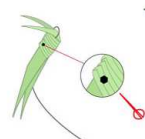

9. Make a hole

Use scissors make a hole.

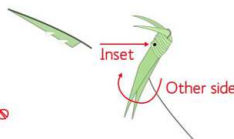

9. Inset wing in body

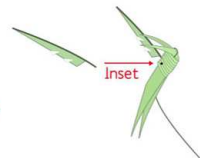

9. Inset other wing in body

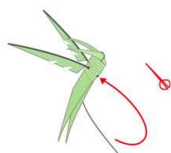

9. Make a hole and insert

Use scissors make a hole and insert.



8. Finish

congratulation.

Grasshopper

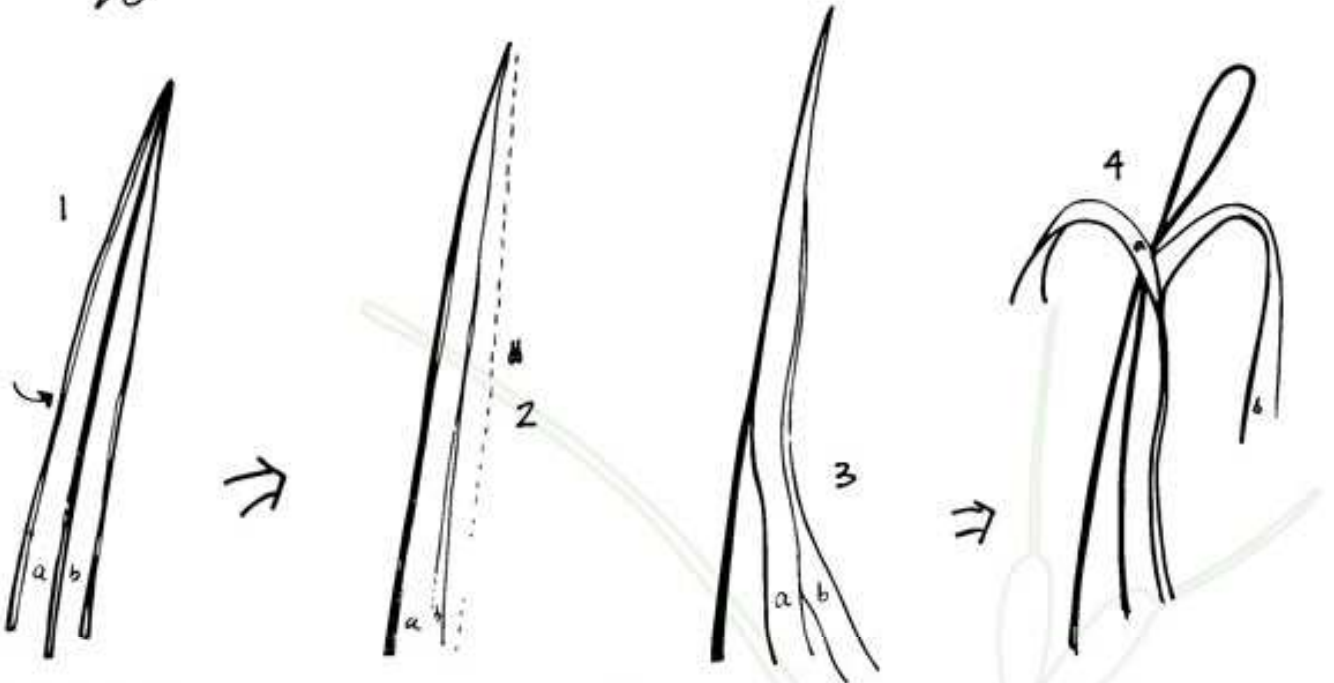

1
First, find a leaf.
And fold along the stem.

2
Remove the edges.

3
Separate two sides
from stem.

4
Reverse the stem.

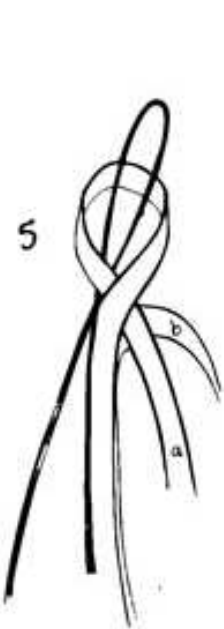

5
Make a circle like this.



6
Tighten it.



7
Then, other side.

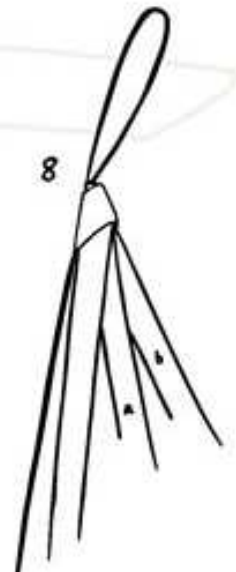

8
Tighten it, too.



Fold 'a' as angle shown.
Then fold around stem.

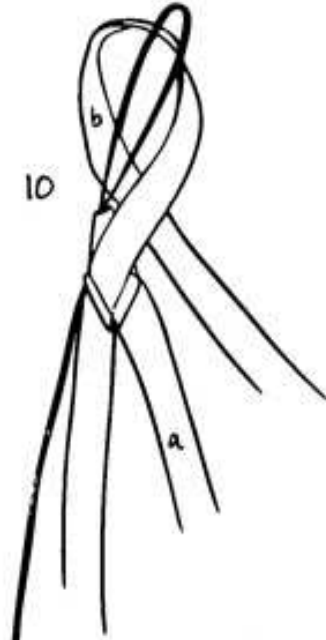

Do the same with 'b'.

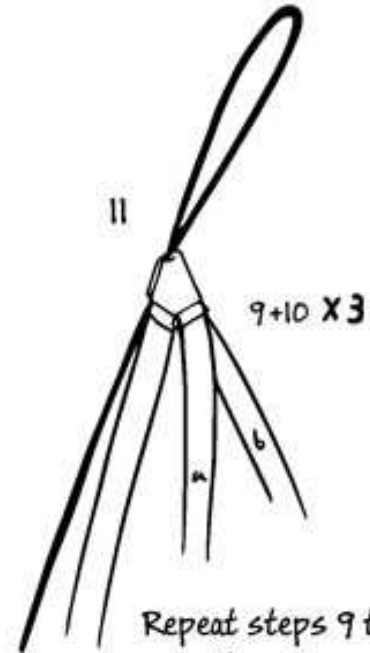

Repeat steps 9 to 10
three times.

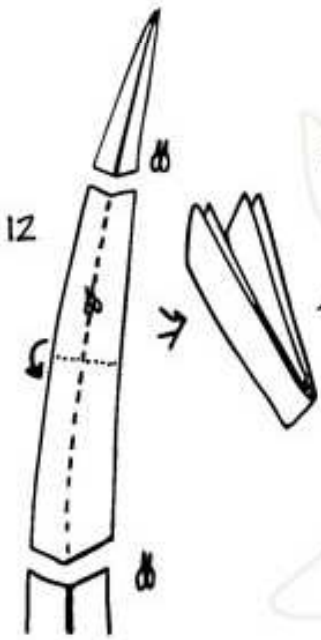

Prepare the wings
as shown.



Add them to the
body from step 11.

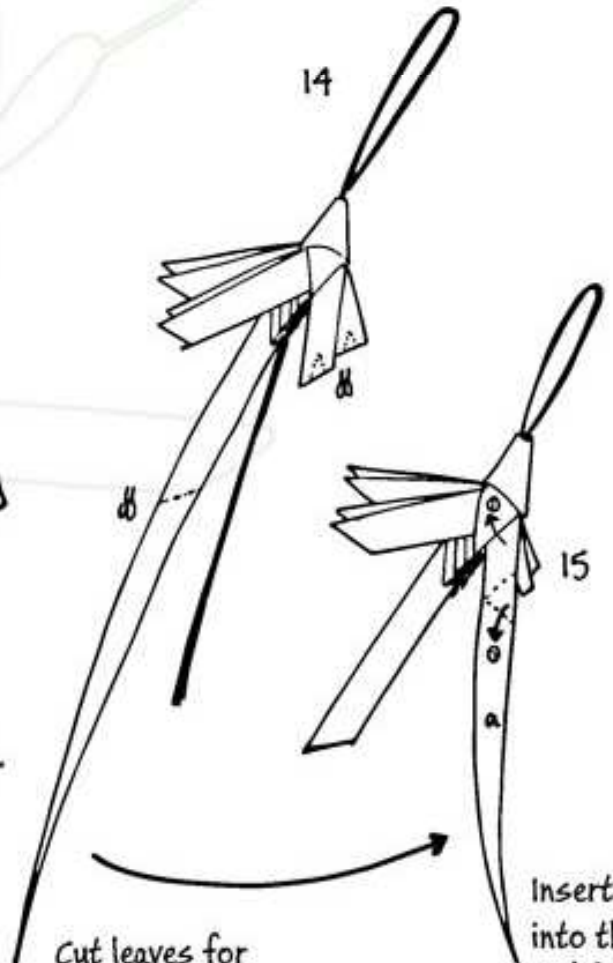

Cut leaves for
the styling.

Insert them
into the body,
and fold both
'a' and 'b'.

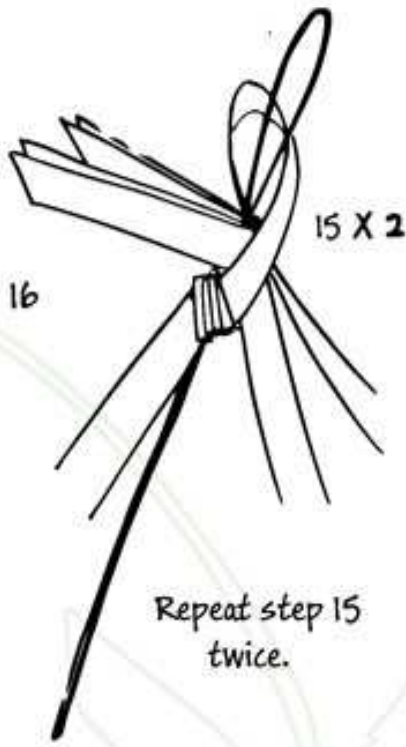

Repeat step 15 twice.

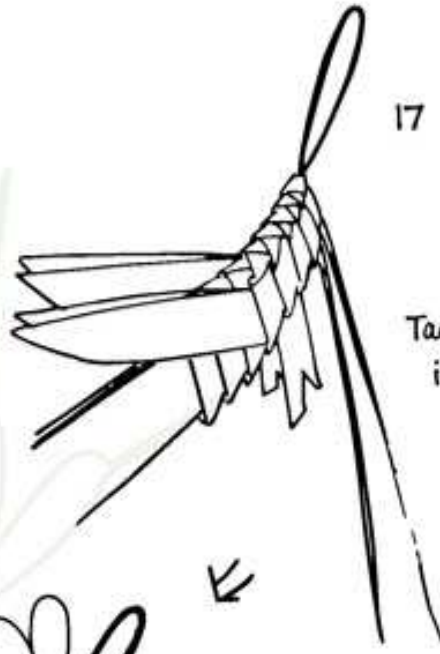

Tackle with the head in good shape.



Make two circles with each side.

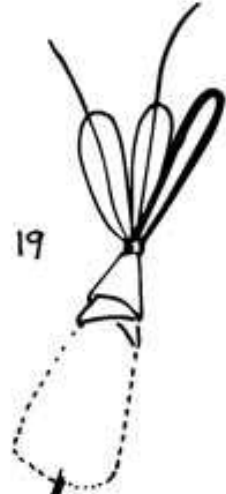

Cross each circle with their own side and tighten the stem.

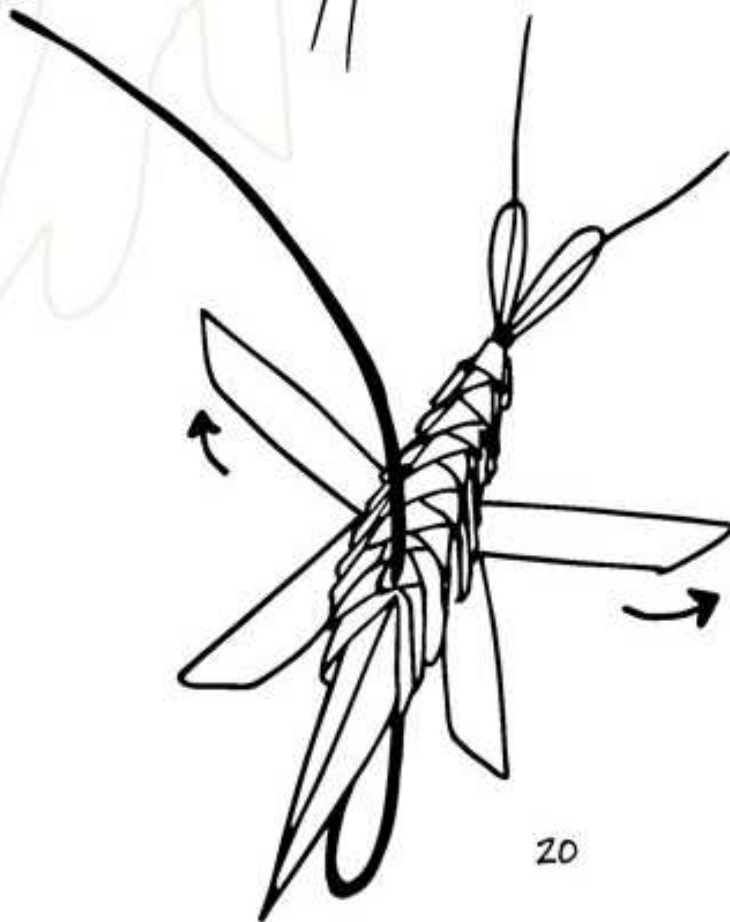

Spread wings and finished!
Enjoy your own craft.

References

- Sudarshan Khanna, Gita Wolf & Anushka Ravishankar (1999) *Toys and Tales with Everyday Materials* , Chennai: Tara Publishing. ISBN: 81-86211-42-X

Books written by the author

- Thought Engineering (2005) Publisher: Sima ye Danesh, Tehran. ISBN: 964-5693-90-x
- Form and Space in Industrial Design (2007) Publisher: Sima ye Danesh, Tehran. ISBN: 964-8972-28-1
- Let's save humans' life with good design (2012) Publisher: Papyrus, Guwahati. ISBN: 978-93-81287-17-0
(you can search the title of this book in the net and download the book)
- Evolution of Automobile Design, A brief Introduction (2013) Publisher: Papyrus, Guwahati. ISBN: 978-93-81287-18-7
(you can search the title of this book in the net and download the book)
- Design & Observation (2013) Publisher in English: Papyrus, Guwahati. ISBN: 978-93-81287-23-1
Publisher in Persian: Azar, Tehran. ISBN: 978-600-6862-01-9 (you can search the title of this book in the net and download the book)